





RF TEST REPORT

Certificate No. : TB210528151
Applicant : Navori SA
Equipment Under Test (EUT)
EUT Name : StiX
Model No. : 3700
Series Model No. : N/A
Brand Name : Navori
Receipt Date : 2021-05-14
Test Date : 2021-05-14 to 2021-06-22
Issue Date : 2021-06-22
Standards : ETSI EN 300 328 V2.2.2: 2019
Conclusions : **PASS**

In the configuration tested, the EUT complied with the standards specified above. The EUT technically complies with the Council Directive 2014/53/EU relating to radio equipment.

Test/Witness Engineer : 
Engineer Supervisor : 
Engineer Manager : 



Camille Li
Ivan Su
Ray Lai



This report details the results of the testing carried out on one sample. The results contained in this test report do not relate to other samples of the same product. The manufacturer should ensure that all products in series production are in conformity with the product sample detailed in the report.

TABLE OF CONTENTS

| | |
|---|-----------|
| 1 GENERAL INFORMATION | 5 |
| 1.1 Client Information..... | 5 |
| 1.2 General Description of EUT (Equipment Under Test) | 5 |
| 1.3 Block Diagram Showing the Configuration of System Tested..... | 9 |
| 1.4 Description of Support Units | 9 |
| 1.5 Description of Operating Mode..... | 10 |
| 1.6 Description of Operating Mode..... | 10 |
| 1.7 Measurement Uncertainty | 11 |
| 1.8 Test Facility..... | 11 |
| 2 TEST RESULTS SUMMARY | 12 |
| 3 TEST SOFTWARE | 13 |
| 4 TEST EQUIPMENT | 14 |
| 5 RF OUTPUT POWER..... | 15 |
| 5.1 Test Standard and Limit..... | 15 |
| 5.2 Test Setup..... | 15 |
| 5.3 Test Procedure..... | 15 |
| 5.4 Deviation From Test Standard..... | 16 |
| 5.5 Test Data..... | 16 |
| 6 POWER SPECTRAL DENSITY | 17 |
| 6.1 Test Standard and Limit..... | 17 |
| 6.2 Test Setup..... | 17 |
| 6.3 Test Procedure..... | 17 |
| 6.4 Deviation From Test Standard..... | 17 |
| 6.5 Test Data..... | 17 |
| 7 DUTY CYCLE, TX-SEQUENCE, TX-GAP | 18 |
| 7.1 Test Standard and Limit..... | 18 |
| 7.2 Test Setup..... | 18 |
| 7.3 Test Procedure..... | 18 |
| 7.4 Deviation From Test Standard..... | 18 |
| 7.5 Test Data..... | 18 |
| 8 MEDIUM UTILIZATION | 19 |
| 8.1 Test Standard and Limit..... | 19 |
| 8.2 Test Setup..... | 19 |
| 8.3 Test Procedure..... | 19 |
| 8.4 Deviation From Test Standard..... | 19 |
| 8.5 Test Data..... | 19 |
| 9 ADAPTIVITY | 20 |
| 9.1 Test Standard and Limit..... | 20 |
| 9.2 Test Setup..... | 21 |
| 9.3 Test Procedure..... | 21 |
| 9.4 Deviation From Test Standard..... | 21 |
| 9.5 Test Data..... | 21 |

| | |
|--|-----------|
| 10 OCCUPIED CHANNEL BANDWIDTH | 22 |
| 10.1 Test Standard and Limit | 22 |
| 10.2 Test Setup..... | 22 |
| 10.3 Test Procedure..... | 22 |
| 10.4 Deviation From Test Standard..... | 22 |
| 10.5 Test Data..... | 22 |
| 11 TRANSMITTER UNWANTED EMISSIONS IN THE OUT-OF-BAND DOMAIN | 23 |
| 11.1 Test Standard and Limit | 23 |
| 11.2 Test Setup..... | 23 |
| 11.3 Test Procedure..... | 23 |
| 11.4 Deviation From Test Standard..... | 23 |
| 11.5 Test Data..... | 23 |
| 12 TRANSMITTER UNWANTED EMISSIONS IN THE SPURIOUS DOMAIN..... | 24 |
| 12.1 Test Standard and Limit | 24 |
| 12.2 Test Setup..... | 24 |
| 12.3 Test Procedure..... | 25 |
| 12.4 Deviation From Test Standard..... | 26 |
| 12.5 Test Data..... | 26 |
| 13 RECEIVER SPURIOUS EMISSIONS | 27 |
| 13.1 Test Standard and Limit | 27 |
| 13.2 Test Setup..... | 27 |
| 13.3 Test Procedure..... | 28 |
| 13.4 Deviation From Test Standard..... | 29 |
| 13.5 Test Data..... | 29 |
| 14 RECEIVER BLOCKING | 30 |
| 14.1 Test Standard and Limit | 30 |
| 14.2 Test Setup..... | 32 |
| 14.3 Test Procedure..... | 33 |
| 14.4 Deviation From Test Standard..... | 34 |
| 14.5 Test Data..... | 34 |
| 15 GEO-LOCATION CAPABILITY | 35 |
| 15.1 Standard Requirement..... | 35 |
| 15.2 Test Result..... | 35 |
| 16 PHOTOGRAPHS – TEST SETUP | 36 |
| ATTACHMENT A-- RF OUTPUT POWER TEST DATA | 37 |
| ATTACHMENT B-- POWER SPECTRAL DENSITY TEST DATA | 38 |
| ATTACHMENT C-- ADAPTIYITY TEST DATA..... | 42 |
| ATTACHMENT D--OCCUPIED CHANNEL BANDWIDTH TEST DATA..... | 54 |
| ATTACHMENT E-- TRANSMITTER UNWANTED EMISSION IN THE OOB DOMAIN TEST DATA | 57 |
| ATTACHMENT F-- TRANSMITTER UNWANTED EMISSIONS IN THE SPURIOUS DOMAIN TEST DATA..... | 60 |
| ATTACHMENT G-- RECEIVER SPURIOUS EMISSIONS TEST DATA | 74 |
| ATTACHMENT H-- RECEIVER BLOCKING TEST DATA..... | 88 |

1 General Information

1.1 Client Information

| | | |
|---------------------|---|---|
| Applicant | : | Navori SA |
| Address | : | Rue du Lion d'Or 4, CH-1003 Lausanne, Switzerland |
| Manufacturer | : | Shenzhen MicoRose Technology Co., Ltd. |
| Address | : | 8B2A, Daqing Building, southeast of the intersection of Shennan Road and Guangshen Expressway, Futian District, Shenzhen, China |

1.2 General Description of EUT (Equipment Under Test)

| | | |
|---|-------------------------|---|
| EUT Name | : | StiX |
| Model No. | : | 3700 |
| Product Description | Operation Frequency: | 802.11b/g/n(HT20):2412MHz~2472Mz 802.11n(HT40): 2422MHz~2462MHz |
| | Modulation Type: | 802.11b: CCK, QPSK, BPSK 802.11g/n: OFDM |
| | Bit Rate of Transmitter | Using 20MHz bandwidth, data rate up to 173.3Mbps Using 40MHz bandwidth, data rate up to 400 Mbps |
| | Channel Separation: | 802.11b/g/n: 5MHz |
| | Number of Channel: | Please see Note(4) |
| | Antenna Designation: | 2.0 dBi PCB Antenna |
| | E.I.R.P: | 802.11b: 13.87dbm(Max) 802.11g: 12.8dbm(Max) 802.11n(HT20): 11.76dbm(Max) |
| Power Rating | : | For Adapter: Input: 100-240V~ Output:5V $\overline{\text{---}}$, 2.5A |
| Software Version | : | android 9.0 |
| Hardware Version | : | V1 |
| Connecting I/O Port(S) | : | Please refer to the User's Manual |
| Remark: The antenna gain and adapter provided by the applicant, the verified for the RF conduction test provided by TOBY test lab. | | |

Note:

- (1) For a more detailed features description, please refer to the manufacturer's specifications or the User's Manual.
- (2) This Test Report is ETSI EN 300 328 for 802.11b/g/n function, under RED Article 3.2.
- (3) The Product Information

a) The type of modulation used by the equipment:

- FHSS
 other forms of modulation

b) In case of FHSS modulation:

- In case of non-Adaptive Frequency Hopping equipment:
The number of Hopping Frequencies:

- In case of Adaptive Frequency Hopping Equipment:
The maximum number of Hopping Frequencies:
The minimum number of Hopping Frequencies:
- The (average) dwell time:

c) Adaptive / non-adaptive equipment:

- non-adaptive Equipment
- adaptive Equipment without the possibility to switch to a non-adaptive mode
- adaptive Equipment which can also operate in a non-adaptive mode

d) In case of adaptive equipment:

The maximum Channel Occupancy Time implemented by the equipment: ms

- The equipment has implemented an LBT mechanism
- In case of non-FHSS equipment:
 - The equipment is Frame Based equipment
 - The equipment is Load Based equipment
 - The equipment can switch dynamically between Frame Based and Load Based equipment
The CCA time implemented by the equipment: μ s
- The equipment has implemented a DAA mechanism
- The equipment can operate in more than one adaptive mode

e) In case of non-adaptive Equipment:

The maximum RF Output Power (e.i.r.p.): dBm

The maximum (corresponding) Duty Cycle:

Equipment with dynamic behaviour, that behaviour is described here. (e.g. the different combinations of duty cycle and corresponding power levels to be declared):

f) The worst case operational mode for each of the following tests:

- RF Output Power
DSSS
- Power Spectral Density
DSSS
- Duty cycle, Tx-Sequence, Tx-gap
- Dwell time, Minimum Frequency Occupation & Hopping Sequence (only for FHSS equipment)
- Accumulated Transmit time, Frequency Occupation & Hopping Sequence (only for FHSS equipment)
- Hopping Frequency Separation (only for FHSS equipment)
- Medium Utilisation

-
- Adaptivity & Receiver Blocking
DSSS
 - Nominal Channel Bandwidth
DSSS
 - Transmitter unwanted emissions in the OOB domain
DSSS
 - Transmitter unwanted emissions in the spurious domain
DSSS
 - Receiver spurious emissions
DSSS

g) The different transmit operating modes (tick all that apply):

- Operating mode 1: Single Antenna Equipment
 - Equipment with only 1 antenna
 - Equipment with 2 diversity antennas but only 1 antenna active at any moment in time

Smart Antenna Systems with 2 or more antennas, but operating in a (legacy) mode where only 1 antenna is used. (e.g. IEEE 802.11™ [i.3] legacy mode in smart antenna systems)

- Operating mode 2: Smart Antenna Systems - Multiple Antennas without beam forming
 - Single spatial stream / Standard throughput / (e.g. IEEE 802.11™ [i.3] legacy mode)
 - High Throughput (> 1 spatial stream) using Occupied Channel Bandwidth 1
 - High Throughput (> 1 spatial stream) using Occupied Channel Bandwidth 2

NOTE: Add more lines if more channel bandwidths are supported.

- Operating mode 3: Smart Antenna Systems - Multiple Antennas with beam forming
 - Single spatial stream / Standard throughput (e.g. IEEE 802.11™ [i.3] legacy mode)
 - High Throughput (> 1 spatial stream) using Occupied Channel Bandwidth 1
 - High Throughput (> 1 spatial stream) using Occupied Channel Bandwidth 2

NOTE: Add more lines if more channel bandwidths are supported.

h) In case of Smart Antenna Systems:

- The number of Receive chains:
- The number of Transmit chains:
 - symmetrical power distribution
 - asymmetrical power distribution

In case of beam forming, the maximum beam forming gain:

NOTE: Beam forming gain does not include the basic gain of a single antenna.

i) Operating Frequency Range(s) of the equipment:

- Operating Frequency Range 1: **2412 MHz to 2472 MHz**
- Operating Frequency Range 2:
- Operating Frequency Range 3:

NOTE: Add more lines if more Frequency Ranges are supported.

j) Nominal Channel Bandwidth(s):

- Occupied Channel Bandwidth 1: **11.994 MHz**
- Occupied Channel Bandwidth 2: **16.426MHz**
- Occupied Channel Bandwidth 3: **17.594 MHz**
- Occupied Channel Bandwidth 4:
- Occupied Channel Bandwidth 5:

NOTE: Add more lines if more channel bandwidths are supported.

k) Type of Equipment (stand-alone, combined, plug-in radio device, etc.):

- Stand-alone
- Combined Equipment (Equipment where the radio part is fully integrated within another type of equipment)
- Plug-in radio device (Equipment intended for a variety of host systems)
- Other

l) The extreme operating conditions that apply to the equipment:

- Operating temperature range: **-10° C to 50° C**
- Operating voltage range: **207V to 253V** AC DC

- Details provided are for the: stand-alone equipment
- combined (or host) equipment
- test jig

m) The intended combination(s) of the radio equipment power settings and one or more antenna assemblies and their corresponding e.i.r.p levels:

- Antenna Type
 - External Antenna
 - Antenna Gain: **2.0dBi**
 - If applicable, additional beamforming gain (excluding basic antenna gain): dB

- Temporary RF connector provided
- No temporary RF connector provided
- Dedicated Antennas (equipment with antenna connector)
 - Single power level with corresponding antenna(s)
 - Multiple power settings and corresponding antenna(s)
 - Number of different Power Levels:
 - Power Level 1: dBm
 - Power Level 2: dBm
 - Power Level 3: dBm

NOTE 1: Add more lines in case the equipment has more power levels.

NOTE 2: These power levels are conducted power levels (at antenna connector).

n) The nominal voltages of the stand-alone radio equipment or the nominal voltages of the combined (host) equipment or test jig in case of plug-in devices:

Details provided are for the: stand-alone equipment

- combined (or host) equipment
- test jig

Supply Voltage AC mains State

- DC State DC voltage :

In case of DC, indicate the type of power source

- Internal Power Supply
- External Power Supply or AC/DC adapter
- Battery:
- Other:

o) Describe the test modes available which can facilitate testing:

The EUT can transmit with test software: WifiTestTool(v1.5.2)

p) The equipment type (e.g. Bluetooth®, IEEE 802.11™ [i.3], proprietary, etc.):
802.11b/g/n(HT20)

q) If applicable, the statistical analysis referred to in clause 5.3.1q:

r) If applicable, the statistical analysis referred to in clause 5.3.1r:

s) Geo-location capability, supported by the equipment:

- Yes
 - The geographical location determined by the equipment as defined in clause 4.3.1.13.2 or clause 4.3.2.12.2 is not accessible to the user.
- No

t) Describe the minimum performance criteria that apply to the equipment (see clause 4.3.1.12.3 or clause 4.3.2.11.3):

The minimum performance criterion shall be a PER less than or equal to 10%.

The intended use of the equipment should be in the normal operation without lost the communication link or no unintentionally operation occurs.

(4) Channel List:

| 802.11b/g/n Channel List | | | | | |
|--------------------------|-----------------|---------|-----------------|---------|-----------------|
| Channel | Frequency (MHz) | Channel | Frequency (MHz) | Channel | Frequency (MHz) |
| 01 | 2412 | 06 | 2437 | 11 | 2462 |
| 02 | 2417 | 07 | 2442 | 12 | 2467 |
| 03 | 2422 | 08 | 2447 | 13 | 2472 |
| 04 | 2427 | 09 | 2452 | | |
| 05 | 2432 | 10 | 2457 | | |

1.3 Block Diagram Showing the Configuration of System Tested

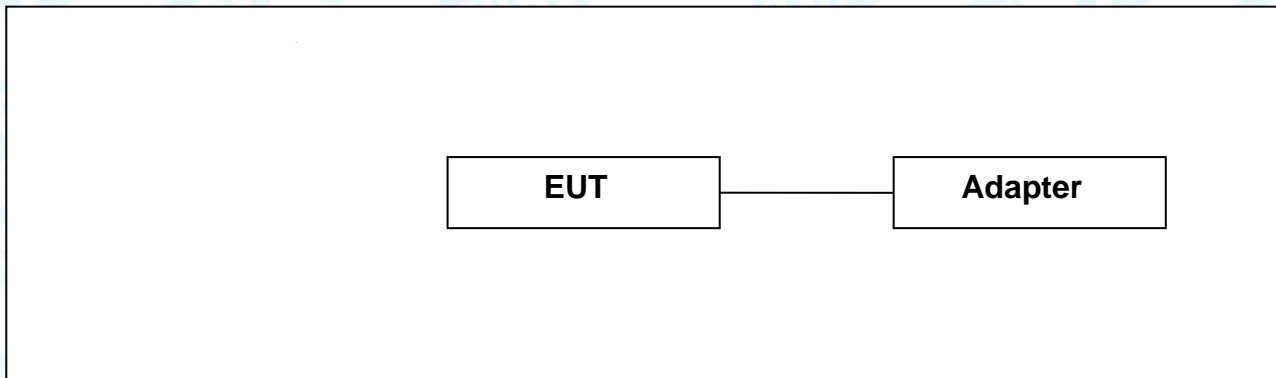

1.4 Description of Support Units

| Equipment Information | | | | |
|-----------------------|-------------------|-------|--------------|----------|
| Name | Model | S/N | Manufacturer | Used "√" |
| Adapter | FJ-SW7260502500DE | ----- | ----- | √ |

1.5 Description of Operating Mode

To investigate the maximum EMI emission characteristics generated from EUT, the test system was pre-scanning tested based on the consideration of following EUT operation mode or test configuration mode which possible have effect on EMI emission level. Each of these EUT operation mode(s) or test configuration mode(s) mentioned above was evaluated respectively.

| Test Mode: Continuously transmitting | | | |
|---|------------------|----------------|-------------------|
| Mode | Data Rate | Channel | Parameters |
| 802.11b | CCK/ 1Mbps | 01 | default |
| | CCK/ 1Mbps | 07 | default |
| | CCK/ 1Mbps | 13 | default |
| 802.11g | OFDM/ 6Mbps | 01 | default |
| | OFDM/ 6Mbps | 07 | default |
| | OFDM/ 6Mbps | 13 | default |
| 802.11n (HT20) | MCS 0 | 01 | default |
| | MCS 0 | 07 | default |
| | MCS 0 | 13 | default |

1.6 Description of Operating Mode

| | |
|-----------------------------|---|
| Normal Temperature(NT): | 25°C |
| Relative Humidity: | 25% to 75% |
| Air Pressure: | 980-1020 hPa |
| Extreme Temperature: | Low Temperature (LT)= -10°C High Temperature (HT)= 50°C |
| Normal Voltage of EUT (NV): | AC 230V |
| Extreme Voltage of the EUT: | Low Voltage(LV)=207V High Voltage(HV)=253V |
| Remark: | The extreme temperature and extreme voltage of the EUT is declared by the manufacturer. |

1.7 Measurement Uncertainty

The reported uncertainty of measurement $y \pm U$, where expanded uncertainty U is based on a standard uncertainty multiplied by a coverage factor of $k=2$, providing a level of confidence of approximately 95 %.

| Test Item | Expanded Uncertainty (U_{Lab}) |
|--|------------------------------------|
| Conducted Emission | ± 3.10 dB |
| Radiated Emission (9kHz to 30 MHz) | ± 4.60 dB |
| RF Power-Conducted | ± 0.95 dB |
| Radiated Emission (30MHz to 1000 MHz) | ± 4.50 dB |
| Radiated Emission (Above 1000MHz) | ± 4.20 dB |
| Temperature | $\pm 0.6^{\circ}\text{C}$ |
| Humidity | $\pm 4\%$ |
| ERP (Radiated) | ± 3.84 dB |
| Conducted Spurious Emission | ± 2.72 dB |
| Frequency Error | $\pm 52.45\text{Hz}$ |
| Occupied Bandwidth | $\pm 3.8\%$ |
| Power Density | ± 0.92 dB |

1.8 Test Facility

The testing report were performed by the Shenzhen Toby Technology Co., Ltd., in their facilities located at 1/F., Building 6, Rundongsheng Industrial Zone, Longzhu, Xixiang, Bao'an, Shenzhen, Guangdong, China. At the time of testing, the following bodies accredited the Laboratory:

CNAS (L5813)

The Laboratory has been accredited by CNAS to ISO/IEC 17025: 2017 General Requirements for the Competence of Testing and Calibration Laboratories for the competence in the field of testing. And the Registration No.: CNAS L5813.

A2LA Certificate No.: 4750.01

The laboratory has been accredited by American Association for Laboratory Accreditation(A2LA) to ISO/IEC 17025: 2017 General Requirements for the Competence of Testing and Calibration Laboratories for the technical competence in the field of Electrical Testing. And the A2LA Certificate No.: 4750.01.FCC Accredited Test Site Number: 854351.

IC Registration No.: (11950A)

The Laboratory has been registered by Certification and Engineering Bureau of Industry Canada for radio equipment testing. The site registration: Site# 11950A.

2 Test Results Summary

| Harmonized Standard ETSI EN 300 328 | | | | | | | |
|--|--|----------------------|----------------------------|---|--------------------|----------------------|--------------|
| Relationship between the present document and the essential requirements of Directive 2014/53/EU | | | | | | | |
| Essential Requirement | | | Requirement Conditionality | | Test Specification | | |
| No | Description | Reference: Clause No | U/C | Condition | E/O | Reference: Clause No | Observations |
| 1 | RF Output Power | 4.3.1.2 or 4.3.2.2 | U | | E | 5.4.2 | PASS Note(2) |
| 2 | Power Spectral Density | 4.3.2.3 | C | Only for non-FHSS equipment | E | 5.4.3 | PASS |
| 3 | Duty Cycle, Tx-Sequence, TX-gap | 4.3.1.3 or 4.3.2.4 | C | Only for non-adaptive equipment | E | 5.4.2 | N/A Note(3) |
| 4 | Accumulated Transmit time, Frequency Occupation & Hopping Sequence | 4.3.1.4 | C | Only for FHSS equipment | E | 5.4.4 | N/A |
| 5 | Hopping Frequency Separation | 4.3.1.5 | C | Only for FHSS equipment | E | 5.4.5 | N/A |
| 6 | Medium Utilization | 4.3.1.6 or 4.3.2.5 | C | Only for non-adaptive equipment | E | 5.4.2 | N/A Note(3) |
| 7 | Adaptivity | 4.3.1.7 or 4.3.2.6 | C | Only for adaptive equipment | | 5.4.6 | PASS Note(3) |
| 8 | Occupied Channel Bandwidth | 4.3.1.8 or 4.3.2.7 | U | | E | 5.4.7 | PASS |
| 9 | Transmitter unwanted emission in the OOB domain | 4.3.1.9 or 4.3.2.8 | U | | E | 5.4.8 | PASS |
| 10 | Transmitter unwanted emissions in the spurious domain | 4.3.1.10 or 4.3.2.9 | U | | E | 5.4.9 | PASS |
| 11 | Receiver spurious emissions | 4.3.1.11 or 4.3.2.10 | U | | E | 5.4.10 | PASS |
| 12 | Receiver Blocking | 4.3.1.12 or 4.3.2.11 | U | | E | 5.4.11 | PASS |
| 13 | Geo-location Capability | 4.3.1.13 or 4.3.2.12 | C | Only for equipment with geo-location capability | X | | |

Note:

(1) "U/C": indicates whether the requirement is to be unconditionally applicable (U) or is conditional upon the manufacturers claimed functionality of the equipment (C).

"Condition": Explains the conditions when the requirement shall or shall not be applicable for a technical requirement which is classified "conditional"

"E/O": indicates whether the test specification forms part of the Essential Radio Test Suite (E) or whether it is one of the Other Test Suite (O).

"X": indicates there is no test specified corresponding to the requirement.

"N/A": indicates test is not applicable in this Test Report.

- (2) The equipment must be complied with as a necessary condition for presumption of conformity, although conformance with the requirement may be claimed by an equivalent test or by manufacturer's assertion supported by appropriate entries in the technical construction file.
- (3) This requirement does not apply for equipment with a maximum declared RF Output power level of less than 10 dBm e.i.r.p. for equipment when operating in a mode where the RF Output power is less than 10 dBm e.i.r.p.
- (4) The equipment was supplied by Host system, so the upper extreme test voltage shall be 1.1 times the nominal voltage of the battery, and the lower extreme test voltage shall be 0.9 times the nominal voltage of the Host system.

3 Test Software

| Test Item | Test Software | Manufacturer | Version No. |
|--------------------------|---------------|--------------|-------------|
| Radiation Emission | EZ-EMC | EZ | FA-03A2RE |
| RF Conducted Measurement | MTS-8310 | MWRfTest | V2.0.0.0 |

4 Test Equipment

| Used Equipment List | | | | | |
|-------------------------------------|--------------------|--------------------|---------------|---------------|---------------|
| Equipment | Manufacturer | Model No. | Serial No. | Last Cal. | Cal. Due Date |
| Wideband Radio Communication Tester | Rohde & Schwarz | CMW500 | 144382 | Sep. 11, 2020 | Sep. 10, 2021 |
| MXA Signal Analyzer | Agilent | N9020A | MY49100060 | Sep. 11, 2020 | Sep. 10, 2021 |
| Vector Signal Generator | Agilent | N5182A | MY50141294 | Sep. 11, 2020 | Sep. 10, 2021 |
| Analog Signal Generator | Agilent | N5181A | MY50141953 | Sep. 11, 2020 | Sep. 10, 2021 |
| RF Power Sensor | DARE!! Instruments | RadiPowerRP R3006W | 17100015SNO26 | Sep. 11, 2020 | Sep. 10, 2021 |
| | DARE!! Instruments | RadiPowerRP R3006W | 17100015SNO29 | Sep. 11, 2020 | Sep. 10, 2021 |
| | DARE!! Instruments | RadiPowerRP R3006W | 17100015SNO31 | Sep. 11, 2020 | Sep. 10, 2021 |
| | DARE!! Instruments | RadiPowerRP R3006W | 17100015SNO33 | Sep. 11, 2020 | Sep. 10, 2021 |
| Spectrum Analyzer | Agilent | E4407B | MY45106456 | Jul. 06, 2020 | Jul. 05, 2021 |
| EMI Test Receiver | Rohde & Schwarz | ESPI | 100010/007 | Jul. 06, 2020 | Jul. 05, 2021 |
| Bilog Antenna | ETS-LINDGREN | 3142E | 00117537 | Mar. 01, 2020 | Feb. 28, 2022 |
| Horn Antenna | ETS-LINDGREN | 3117 | 00143207 | Mar. 01, 2020 | Feb. 28, 2022 |
| Horn Antenna | ETS-LINDGREN | BBHA 9170 | BBHA9170582 | Mar. 01, 2020 | Feb. 28, 2022 |
| Pre-amplifier | Sonoma | 310N | 185903 | Feb. 25, 2021 | Feb. 24, 2022 |
| Pre-amplifier | HP | 8449B | 3008A00849 | Feb. 25, 2021 | Feb. 24, 2022 |
| Pre-amplifier | SKET | LNPA_1840G-50 | SK201904032 | Feb. 25, 2021 | Feb. 24, 2022 |
| Cable | HUBER+SUHNER | 100 | SUCOFLEX | Feb. 25, 2021 | Feb. 24, 2022 |
| Positioning Controller | ETS-LINDGREN | 2090 | N/A | N/A | N/A |
| Temp. & Humidity Chamber | ZHONG ZHI | CZ-A-225D | HW08053 | Jul. 06, 2020 | Jul. 05, 2021 |
| DC Power Supply | MATRIX | MPS-3005L-3 | D806050W | Jul. 06, 2020 | Jul. 05, 2021 |
| AC Power Supply | HengJie | HPC-1110 | 2010007 | Jul. 06, 2020 | Jul. 05, 2021 |

5 RF Output Power

5.1 Test Standard and Limit

5.1.1 Test Standard

ETSI EN 300 328 V2.2.2:2019 clause 4.3.2.2

5.1.2 Test Limit

| Test Item | Limit |
|-------------------------------------|------------------|
| Equivalent isotropic radiated power | -10 dBW (20 dBm) |

5.2 Test Setup

Normal Condition

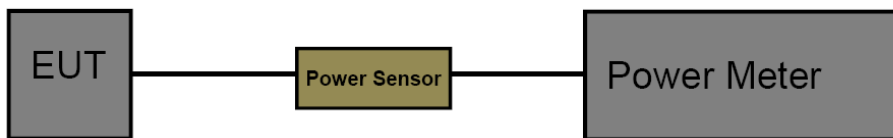

Extreme Condition

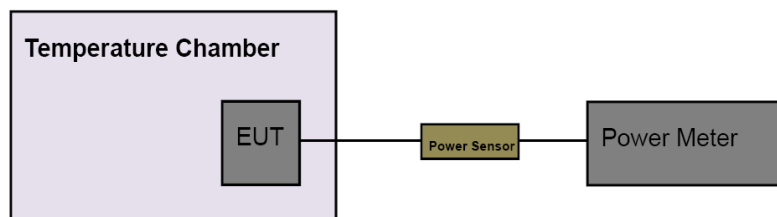

5.3 Test Procedure

Please refer to ETSI EN 300 328 (V2.2.2) clause 5.4.2

- The EUT was connected to RF power meter via a broadband power sensor as show the block above. Use the following settings:
 - Sample speed 1 MS/s.
 - The samples shall represent the RMS power of the signal.
- Recorded the highest of all P_{burst} values as “A” dBm.

Between the start and stop times of each individual burst calculate the RMS power over the burst using the formula below. Save these P_{burst} values, as well as the start and stop times for each burst.

$$P_{burst} = \frac{1}{k} \sum_{n=1}^k P_{sample}(n)$$

With ‘k’ being the total of samples and ‘n’ the actual sample number

- The RF Output Power (P) shall be calculated using the formula below:

$$P=A+G+Y.$$

“A” dBm: The highest of all P_{burst} values be used for maximum e.i.r.p calculations.

“G” dBi: The antenna assembly gain in dBi of the individual antenna.

“Y” dB: The beamforming Gain in dB.

4. The measurement shall be repeated at the lowest, the middle, and the highest channel of the stated frequency range. These measurements shall also be performed at the normal and the extreme test conditions.

5.4 Deviation From Test Standard

No deviation

5.5 Test Data

Please refer to the Attachment A.

6 Power Spectral Density

6.1 Test Standard and Limit

6.1.1 Test Standard

ETSI EN 300 328 V2.2.2:2019 clause 4.3.2.3.

6.1.2 Limits

| Test Item | Limit |
|--------------------|--|
| Peak Power Density | FHSS N/A |
| | DSSS/OFDM, Other wide band modulation 10 mW/MHz |

6.2 Test Setup

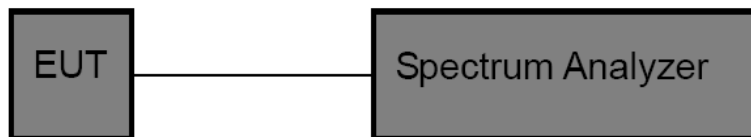

6.3 Test Procedure

Please refer to ETSI EN 300 328 (V2.2.2) clause 5.4.3

1. Connect the EUT to the output port of the spectrum analyzer.
2. The measurement shall be repeated at the lowest, the middle, and the highest channel of the stated frequency range.

6.4 Deviation From Test Standard

No deviation

6.5 Test Data

Please refer to the Attachment B.

7 Duty Cycle, Tx-Sequence, Tx-Gap

7.1 Test Standard and Limit

7.1.1 Test Standard

ETSI EN 300 328 V2.2.2:2019 clause 4.3.2.4

7.1.2 Limits

| Requirement | Limit |
|---|---|
| Adaptive equipment | N/A |
| Equipment (or operating mode) with maximum RF output power less than 10 dBm | N/A |
| Non-adaptive equipment with RF power large than 10 dBm | The Duty Cycle shall be equal to or less than the maximum value declared by the supplier. The Tx-sequence time shall be equal to or less than 10 ms. The minimum Tx-gap time following a Tx-sequence shall be equal to the duration of that proceeding Tx-sequence with a minimum of 3,5 ms. |

7.2 Test Setup

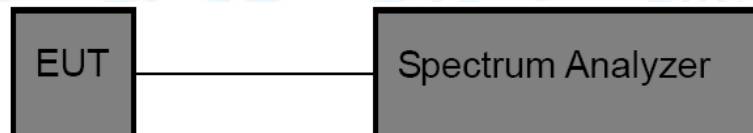

7.3 Test Procedure

Please refer to ETSI EN 300 328 (V2.2.2) clause 5.4.2

1. Connect the EUT to the equipment as above.
2. The measurement shall be repeated at the lowest and the highest channel of the stated frequency range.

7.4 Deviation From Test Standard

No deviation

7.5 Test Data

- (1)The EUT is adaptive equipment and does not support non-adaptive mode, hence this requirement is not applicable.
- (2)The EUT RF output power less than 10 dBm, hence this requirement is not applicable.

8 Medium Utilization

8.1 Test Standard and Limit

8.1.1 Test Standard

ETSI EN 300 328 V2.2.2:2019 clause 4.3.2.5

8.1.2 Limits

| | Limit |
|--|---|
| Wide Band Modulation | $MU = (P/100 \text{ mw}) * DC$ Where: MU is Medium Utilisation. P is the RF output power, expressed in mW. DC is the Duty Cycle expressed in %. The maximum Medium Utilisation factor shall be 10%. |
| Remark: (1) This requirement does not apply to adaptive equipment unless operating in a non-adaptive mode. (2) This requirement does not apply for equipment with a maximum declared RF Output power of less than 10 dBm e.i.r.p or equipment when operating in a mode where the RF Output power is less than 10 dBm e.i.r.p | |

8.2 Test Setup

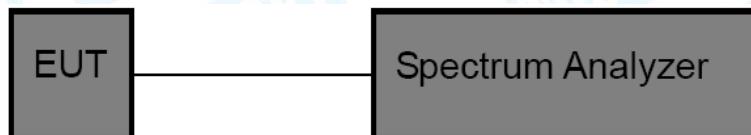

8.3 Test Procedure

Please refer to ETSI EN 300 328 (V2.2.2) clause 5.4.2

1. Connect the EUT to the equipment as above.
2. The measurement shall be repeated at the lowest and the highest channel of the stated frequency range.

8.4 Deviation From Test Standard

No deviation

8.5 Test Data

- (1) The EUT is adaptive equipment and does not support non-adaptive mode, hence this requirement is not applicable.
- (2) The EUT RF output power less than 10 dBm, hence this requirement is not applicable.

9 Adaptivity

9.1 Test Standard and Limit

9.1.1 Test Standard

ETSI EN 300 328 V2.2.2:2019 clause 4.3.2.6

9.1.2 Limits

Non-LBT based Detect and Avoid:

- 1 The frequency shall remain unavailable for a minimum time equal to 1 second after which the channel may be considered again as an „available“ channel;
- 2 COT ≤ 40 ms;
- 3 Idle Period = 5% of COT;
- 4 Detection threshold level = $-70 \text{ dBm/MHz} + 10 \times \log_{10} (100\text{mW}/P_{\text{out}})$ / (P_{out} in mW e.i.r.p.)

LBT based Detect and Avoid (Frame Based Equipment):

- 1 Minimum Clear Channel Assessment (CCA) time = 18 us;
- 2 CCA observation time declared by the supplier;
- 3 COT = 1~10 ms;
- 4 Idle Period = 5% of COT;
- 5 Detection threshold level = $-70 \text{ dBm/MHz} + 10 \times \log_{10} (100\text{mW}/P_{\text{out}})$ / (P_{out} in mW e.i.r.p.)

LBT based Detect and Avoid (Load Based Equipment):

- 1 Minimum Clear Channel Assessment (CCA) time = 18 us;
- 2 CCA declared by the manufacturer;
- 3 COT ≤ 13 ms;
- 4 Detection threshold level = $-70 \text{ dBm/MHz} + 10 \times \log_{10} (100\text{mW}/P_{\text{out}})$ / (P_{out} in mW e.i.r.p.)

Short Control Signalling Transmissions: Short Control Signalling Transmissions shall have a maximum duty cycle TxOn / (TxOn + TxOff) ratio of 10 % within any observation period of 50 ms.

9.2 Test Setup

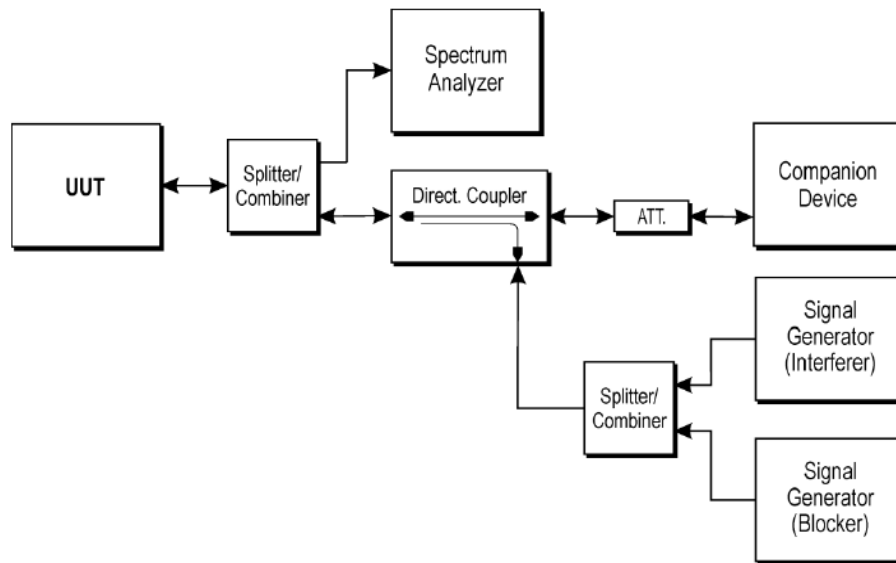

9.3 Test Procedure

Please refer to ETSI EN 300 328 (V2.2.2) clause 5.4.6

1. Connect the EUT to the equipment as above.
2. The measurement shall be repeated at the lowest and the highest channel of the stated frequency range.

9.4 Deviation From Test Standard

No deviation

9.5 Test Data

Please refer to the Attachment C.

10 Occupied Channel Bandwidth

10.1 Test Standard and Limit

10.1.1 Test Standard

ETSI EN 300 328 V2.2.2:2019 clause 4.3.2.7

10.1.2 Limits

| Occupied Channel Bandwidth | |
|---|---|
| Equipment | Limit |
| All types of Equipment | The Occupied Bandwidth shall fall completely within the band give in 2400 MHz to 2438.5 MHz |
| for non-adaptive equipment using wide band modulations other than FHSS and with e.i.r.p greater than 10 dBm | <20MHz |
| For non-adaptive Frequency Hopping equipment with e.i.r.p greater than 10 dBm | <5MHz |

10.2 Test Setup

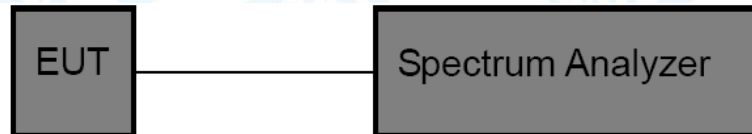

10.3 Test Procedure

Please refer to ETSI EN 300 328 (V2.2.2) clause 5.4.7

1. Connect the EUT to the output port of the spectrum analyzer.
2. Set the spectrum analyzer as following:
 - Centre Frequency: The centre frequency of the channel under test.
 - Resolution BW: > 1% of the span
 - Video BW: 3*RBW
 - Frequency Span for frequency hopping equipment: Lowest frequency separation that is used within the hopping sequence
 - Frequency Span for other types of equipment: 2*Nominal Channel Bandwidth
 - Detector Mode: MaxPeak
 - Trace Mode: Max Hold
 - Sweep Time: Auto
3. The measurement shall be repeated at the lowest and the highest channel of the stated frequency range.

10.4 Deviation From Test Standard

No deviation

10.5 Test Data

Please refer to the Attachment D.

11 Transmitter Unwanted Emissions in the out-of-band Domain

11.1 Test Standard and Limit

11.1.1 Test Standard

ETSI EN 300 328 V2.2.2:2019 clause 4.3.2.8

11.1.2 Limits

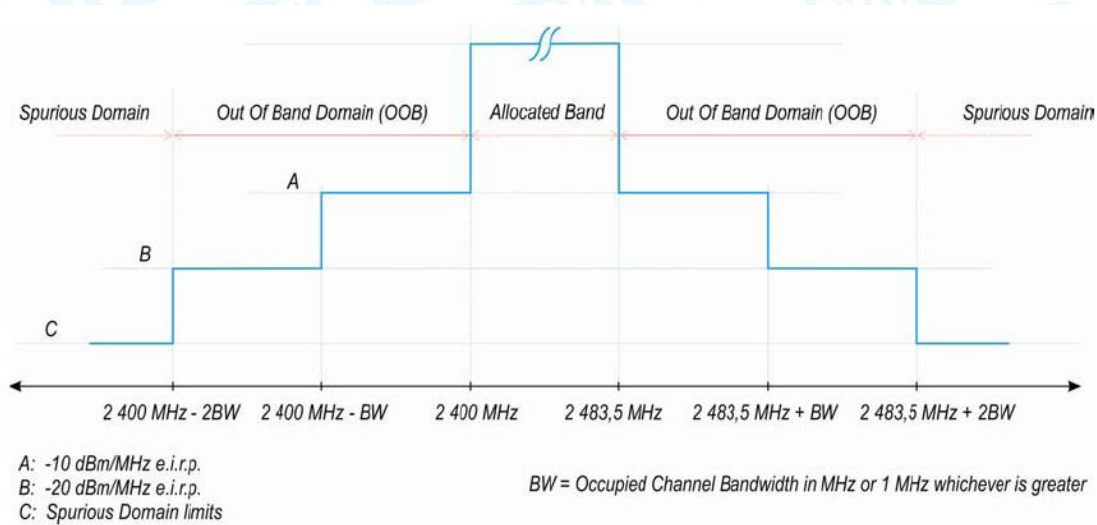

11.2 Test Setup

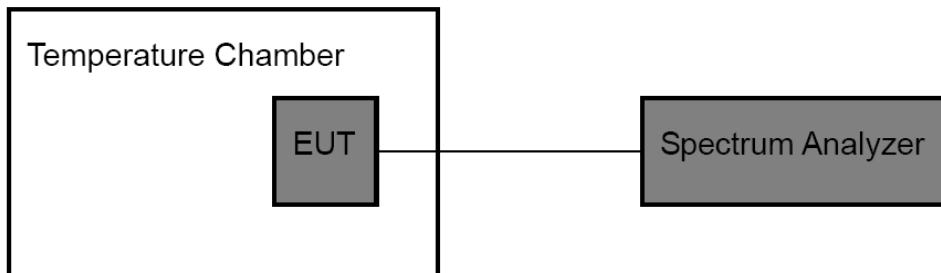

11.3 Test Procedure

Please refer to ETSI EN 300 328 (V2.2.2) clause 5.4.8

1. Connect the EUT to the output port of the spectrum analyzer.
2. The measurement shall be repeated at the lowest and the highest channel of the stated frequency range.

11.4 Deviation From Test Standard

No deviation

11.5 Test Data

Please refer to the Attachment E.

12 Transmitter Unwanted Emissions in the Spurious Domain

12.1 Test Standard and Limit

12.1.1 Test Standard

ETSI EN 300 328 V2.2.2:2019 clause 4.3.2.9

12.1.2 Limits

Transmitter limits for Spurious Emissions

| Frequency Range | Maximum Power e.r.p. (≤ 1 GHz) e.i.r.p. (> 1 GHz) | Bandwidth |
|---------------------|--|-----------|
| 30 MHz to 47 MHz | -36 dBm | 100 kHz |
| 47 MHz to 74 MHz | -54 dBm | 100 kHz |
| 74 MHz to 87.5 MHz | -36 dBm | 100 kHz |
| 87.5 MHz to 118 MHz | -54 dBm | 100 kHz |
| 118 MHz to 174 MHz | -36 dBm | 100 kHz |
| 174 MHz to 230 MHz | -54 dBm | 100 kHz |
| 230 MHz to 470 MHz | -36 dBm | 100 kHz |
| 470 MHz to 694 MHz | -54 dBm | 100 kHz |
| 694 MHz to 1 GHz | -36 dBm | 100 kHz |
| 1 GHz to 12.75 GHz | -30 dBm | 1 MHz |

12.2 Test Setup

(A) Radiated Emission Test Set-Up Frequency Below 1 GHz.

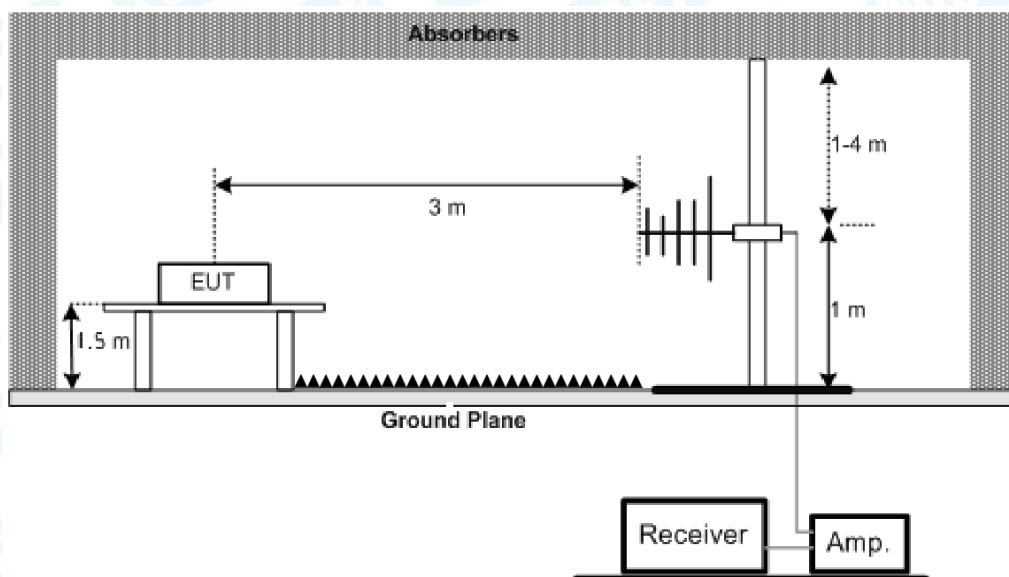

(B) Radiated Emission Test Set-Up Frequency Above 1 GHz.

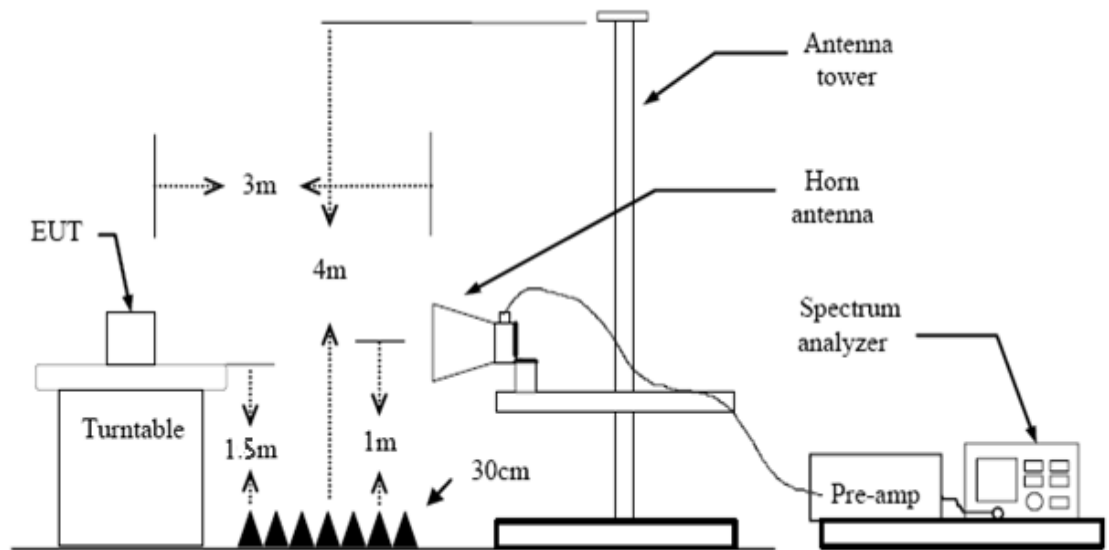

12.3 Test Procedure

Please refer to ETSI EN 300 328 (V2.2.2) clause 5.4.9

1. The EUT was placed on the top of the turntable in chamber.
2. The test shall be made in the transmitting mode. The turntable was rotated by 360 degrees to determine the position of the highest radiation.
3. Set the spectrum analyzer as follows to measure the emissions 30 MHz to 1000 MHz:
 - Resolution BW : 100 kHz.
 - Resolution BW :300 kHz.
 - Detector : Peak.
 - Trace Mode : Max Hold.
 - Filter type: 3 dB (Gaussian)
 - Sweep Points : ≥ 19400
 - Sweep Time : Auto
4. Set the spectrum analyzer as follows to measure the emissions 1 GHz to 12.75 GHz:
 - Resolution BW : 1 MHz.
 - Resolution BW : 3 MHz.
 - Detector : Peak.
 - Trace Mode : Max Hold.
 - Filter type: 3 dB (Gaussian)
 - Sweep Points : ≥ 23500
 - Sweep Time : Auto
5. For 30~1000MHz spurious emissions measurement, the broad band bi-log receiving antenna was placed 3 meters far away from the turntable. .
6. The broadband receiving antenna was fixed on the same height with the EUT to find each suspected emissions of both horizontal and vertical polarization. Each recorded suspected value is indicated as Read Level (Raw).
7. Replace the EUT by standard antenna and feed the RF port by signal generator.
8. Adjust the frequency of the signal generator to the suspected emission and slightly rotate

- the turntable to locate the position with maximum reading.
9. Adjust the power level of the signal generator to reach the same reading with Read Level (Raw).
 10. The level of the spurious emission is the power level of (g) plus the gain of the standard antenna in dBi and minus the loss of the cable used between the signal generator and the standard antenna.
 11. If the measuring emissions that exceed the level of 6 dB below the applicable limit, the resolution bandwidth shall be switched to 30 kHz and the span shall be adjusted accordingly. If the level does not change by more than 2 dB, it is a narrowband emission; the observed value shall be recorded. If the level changes by more than 2 dB, the emission is a wideband emission and its level shall be measured and recorded.
 12. The measurement shall be repeated at the lowest and the highest channel of the stated frequency range.

12.4 Deviation From Test Standard

No deviation

12.5 Test Data

Please refer to the Attachment F.

13 Receiver Spurious Emissions

13.1 Test Standard and Limit

13.1.1 Test Standard

ETSI EN 300 328 V2.2.2:2019 clause 4.3.2.10

13.1.2 Limits

Spurious Emission Limits for Receivers

| Frequency Range | Maximum Power e.r.p. | Bandwidth |
|--------------------|-------------------------|-----------|
| 30 MHz to 1 GHz | -57 dBm | 100 kHz |
| 1 GHz to 12.75 GHz | -47 dBm | 1 MHz |

13.2 Test Setup

(A) Radiated Emission Test Set-Up Frequency Below 1 GHz.

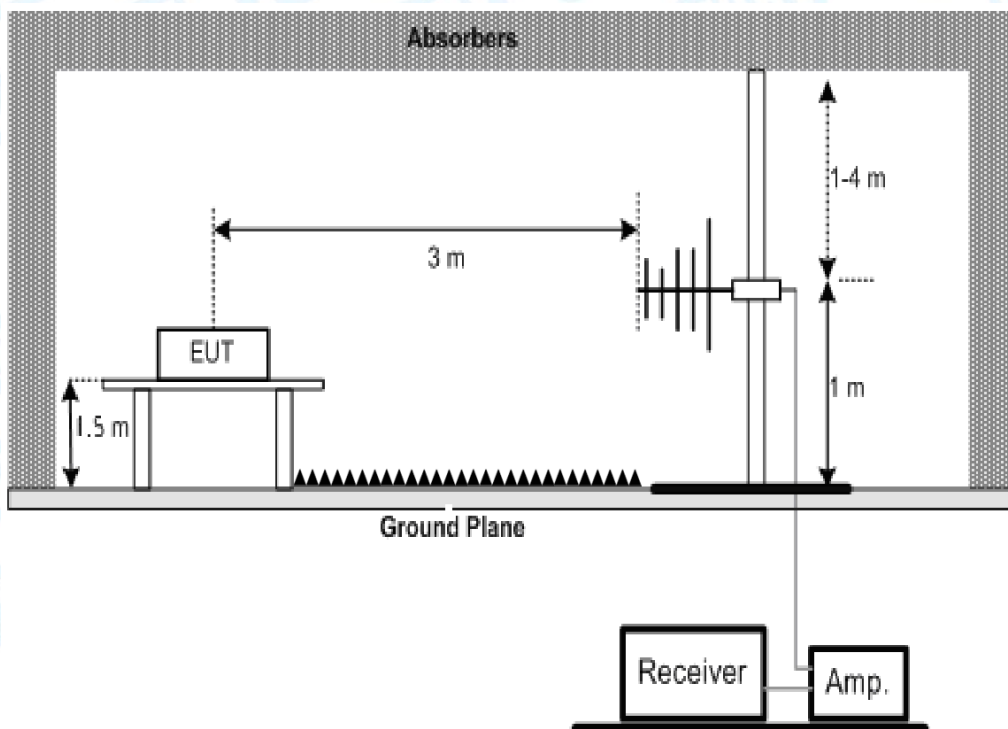

(B) Radiated Emission Test Set-Up Frequency Above 1 GHz.

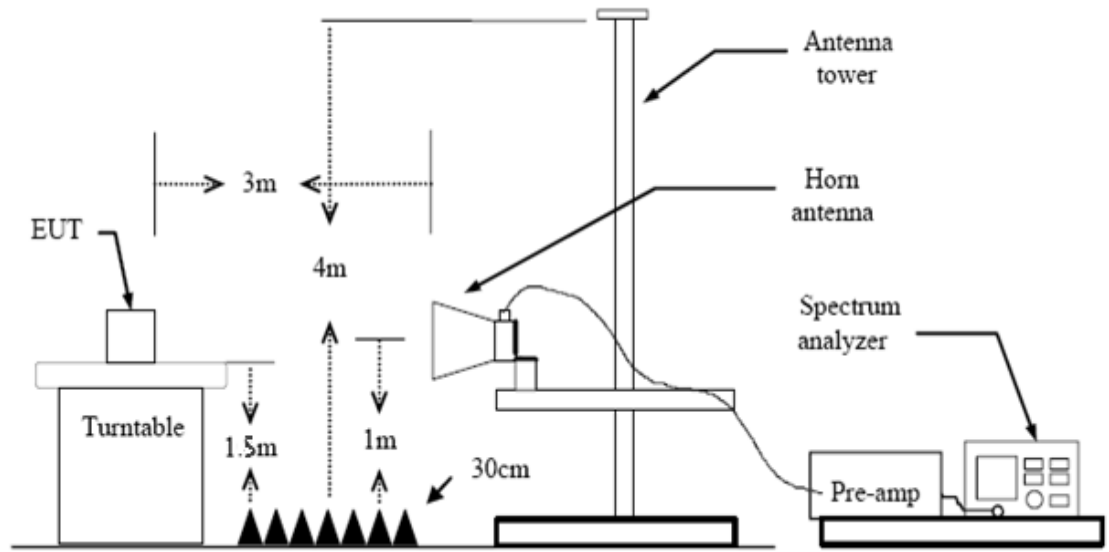

13.3 Test Procedure

Please refer to ETSI EN 300 328 (V2.2.2) clause 5.4.10

1. The EUT was placed on the top of the turntable in chamber.
2. The test shall be made in the transmitting mode. The turntable was rotated by 360 degrees to determine the position of the highest radiation.
3. Set the spectrum analyzer as follows to measure the emissions 30 MHz to 1000 MHz:
 - Resolution BW : 100 kHz.
 - Resolution BW :300 kHz.
 - Detector : Peak.
 - Trace Mode : Max Hold.
 - Filter type: 3 dB (Gaussian)
 - Sweep Points : ≥ 19400
 - Sweep Time : Auto
4. Set the spectrum analyzer as follows to measure the emissions 1 GHz to 12.75 GHz:
 - Resolution BW : 1 MHz.
 - Resolution BW : 3 MHz.
 - Detector : Peak.
 - Trace Mode : Max Hold.
 - Filter type: 3 dB (Gaussian)
 - Sweep Points : ≥ 23500
 - Sweep Time : Auto
5. For 30~1000MHz spurious emissions measurement, the broad band bi-log receiving antenna was placed 3 meters far away from the turntable. .
6. The broadband receiving antenna was fixed on the same height with the EUT to find each suspected emissions of both horizontal and vertical polarization. Each recorded suspected value is indicated as Read Level (Raw).

7. Replace the EUT by standard antenna and feed the RF port by signal generator.
8. Adjust the frequency of the signal generator to the suspected emission and slightly rotate the turntable to locate the position with maximum reading.
9. Adjust the power level of the signal generator to reach the same reading with Read Level (Raw).
10. The level of the spurious emission is the power level of (g) plus the gain of the standard antenna in dBi and minus the loss of the cable used between the signal generator and the standard antenna.
11. If the measuring emissions that exceed the level of 6 dB below the applicable limit, the resolution bandwidth shall be switched to 30 kHz and the span shall be adjusted accordingly. If the level does not change by more than 2 dB, it is a narrowband emission; the observed value shall be recorded. If the level changes by more than 2 dB, the emission is a wideband emission and its level shall be measured and recorded.
12. The measurement shall be repeated at the lowest and the highest channel of the stated frequency range.

13.4 Deviation From Test Standard

No deviation

13.5 Test Data

Please refer to the Attachment G.

14 Receiver Blocking

14.1 Test Standard and Limit

14.1.1 Test Standard

ETSI EN 300 328 V2.2.2:2019 clause 4.3.2.11

14.1.2 Test Definition

Receiver blocking is a measure of the ability of the equipment to receive a wanted signal on its operating channel without exceeding a given degradation due to the presence of an unwanted input signal (blocking signal) on frequencies other than those of the operating band and spurious responses.

14.1.3 Test Limits

While maintaining the minimum performance criteria as defined in clause 4.3.1.11.3, the blocking levels at specified frequency offsets shall be equal to or greater than the limits defined for the applicable receiver category provided in table 14, table 15 or table 16.

Table 14: Receiver Blocking parameters for Receiver Category 1 equipment

| Wanted signal mean power from companion device (dBm) (see notes 1 and 4) | Blocking signal frequency (MHz) | Blocking signal power (dBm) (see note 4) | Type of blocking signal |
|--|--|---|-------------------------|
| $(-133 \text{ dBm} + 10 \times \log_{10}(\text{OCBW}))$ or -68 dBm whichever is less (see note 2) | 2 380 2 504 | -34 | CW |
| $(-139 \text{ dBm} + 10 \times \log_{10}(\text{OCBW}))$ or -74 dBm whichever is less (see note 3) | 2 300 2 330 2 360 2 524 2 584 2 674 | | |
| NOTE 1: OCBW is in Hz. | | | |
| NOTE 2: In case of radiated measurements using a companion device and the level of the wanted signal from the companion device cannot be determined, a relative test may be performed using a wanted signal up to $P_{\text{min}} + 26 \text{ dB}$ where P_{min} is the minimum level of wanted signal required to meet the minimum performance criteria as defined in clause 4.3.1.12.3 in the absence of any blocking signal. | | | |
| NOTE 3: In case of radiated measurements using a companion device and the level of the wanted signal from the companion device cannot be determined, a relative test may be performed using a wanted signal up to $P_{\text{min}} + 20 \text{ dB}$ where P_{min} is the minimum level of wanted signal required to meet the minimum performance criteria as defined in clause 4.3.1.12.3 in the absence of any blocking signal. | | | |
| NOTE 4: The level specified is the level at the UUT receiver input assuming a 0 dBi antenna assembly gain. In case of conducted measurements, this level has to be corrected for the (in-band) antenna assembly gain (G). In case of radiated measurements, this level is equivalent to a power flux density (PFD) in front of the UUT antenna with the UUT being configured/positioned as recorded in clause 5.4.3.2.2. | | | |

Table 15: Receiver Blocking parameters receiver Category 2 equipment

| Wanted signal mean power from companion device (dBm) (see notes 1 and 3) | Blocking signal frequency (MHz) | Blocking signal power (dBm) (see note 3) | Type of blocking signal |
|---|----------------------------------|---|-------------------------|
| (-139 dBm + 10 × log ₁₀ (OCBW) + 10 dB) or (-74 dBm + 10 dB) whichever is less (see note 2) | 2 380 2 504 2 300 2 584 | -34 | CW |
| <p>NOTE 1: OCBW is in Hz.</p> <p>NOTE 2: In case of radiated measurements using a companion device and the level of the wanted signal from the companion device cannot be determined, a relative test may be performed using a wanted signal up to P_{min} + 26 dB where P_{min} is the minimum level of wanted signal required to meet the minimum performance criteria as defined in clause 4.3.1.12.3 in the absence of any blocking signal.</p> <p>NOTE 3: The level specified is the level at the UUT receiver input assuming a 0 dBi antenna assembly gain. In case of conducted measurements, this level has to be corrected for the (in-band) antenna assembly gain (G). In case of radiated measurements, this level is equivalent to a power flux density (PFD) in front of the UUT antenna with the UUT being configured/positioned as recorded in clause 5.4.3.2.2.</p> | | | |

Table 16: Receiver Blocking parameters receiver Category 3 equipment

| Wanted signal mean power from companion device (dBm) (see notes 1 and 3) | Blocking signal frequency (MHz) | Blocking signal power (dBm) (see note 3) | Type of blocking signal |
|---|----------------------------------|---|-------------------------|
| (-139 dBm + 10 × log ₁₀ (OCBW) + 20 dB) or (-74 dBm + 20 dB) whichever is less (see note 2) | 2 380 2 504 2 300 2 584 | -34 | CW |
| <p>NOTE 1: OCBW is in Hz.</p> <p>NOTE 2: In case of radiated measurements using a companion device and the level of the wanted signal from the companion device cannot be determined, a relative test may be performed using a wanted signal up to P_{min} + 30 dB where P_{min} is the minimum level of wanted signal required to meet the minimum performance criteria as defined in clause 4.3.1.12.3 in the absence of any blocking signal.</p> <p>NOTE 3: The level specified is the level at the UUT receiver input assuming a 0 dBi antenna assembly gain. In case of conducted measurements, this level has to be corrected for the (in-band) antenna assembly gain (G). In case of radiated measurements, this level is equivalent to a power flux density (PFD) in front of the UUT antenna with the UUT being configured/positioned as recorded in clause 5.4.3.2.2.</p> | | | |

Receiver category 1:

The following equipment shall be categorized as receiver category 1 equipment:

- Adaptive equipment with a maximum RF output power greater than 10 dBm e.i.r.p.
- NOTE: Non-adaptive equipment is categorized as receiver category 2 or receiver category 3.

Receiver category 2:

The following equipment shall be categorized as receiver category 2 equipment:

- non-adaptive equipment with a Medium Utilization (MU) factor greater than 1 % and less than or equal to 10 % (irrespective of the maximum RF output power); or
- equipment (adaptive or non-adaptive) with a maximum RF output power greater than 0 dBm e.i.r.p. and less than or equal to 10 dBm e.i.r.p.

Receiver category 3:

The following equipment shall be categorized as receiver category 3 equipment:

- non-adaptive equipment with a maximum Medium Utilization (MU) factor of 1 % (irrespective of the maximum RF output power); or
- equipment (adaptive or non-adaptive) with a maximum RF output power of 0 dBm e.i.r.p.

14.2 Test Setup

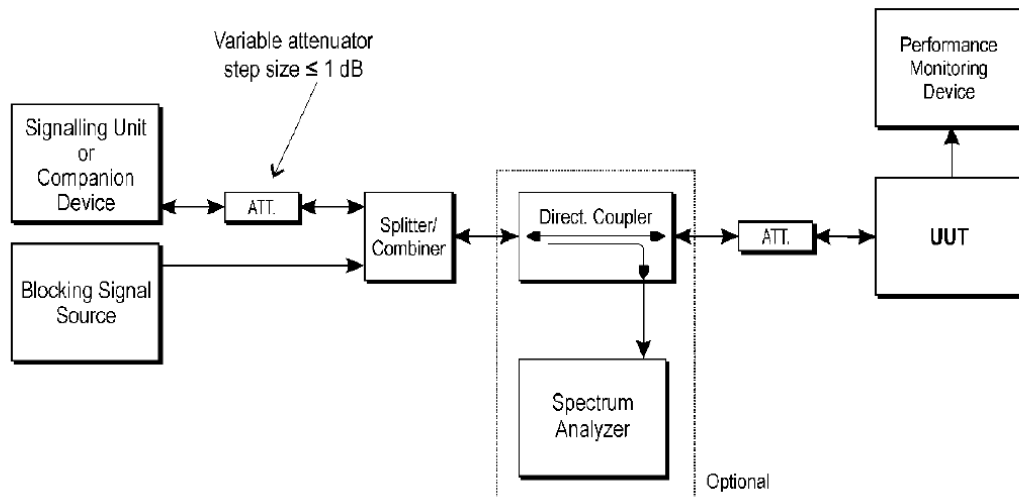

14.3 Test Procedure

Please refer to ETSI EN 300 328 (V2.2.2) clause 5.4.11

Conducted measurements:

Step 1:

- For non-FHSS equipment, the UUT shall be set to the lowest operating channel on which the blocking test has to be performed (see clause 5.4.11.1).

Step 2:

- The blocking signal generator is set to the first frequency as defined in the appropriate table corresponding to the receiver category and type of equipment.

Step 3:

- With the blocking signal generator switched off, a communication link is established between the UUT and the associated companion device using the test setup shown in figure 6.

- Unless the option provided in note 2 of the applicable table referred to in clause 5.4.11.2.1 is used, the level of the wanted signal shall be set to the value provided in the table corresponding to the receiver category and type of equipment. The test procedure defined in clause 5.4.2, and more in particular clause 5.4.2.2.1.2, can be used to measure the (conducted) level of the wanted signal however no correction shall be made for antenna gain of the companion device (step 6 in clause 5.4.2.2.1.2 shall be ignored). This level may be measured directly at the output of the companion device and a correction is made for the coupling loss into the UUT. The actual level for the wanted signal shall be recorded in the test report.

- When the option provided in note 2 of the applicable table referred to in clause 5.4.11.2.1 is used, the attenuation of the variable attenuator shall be increased in 1 dB steps to a value at which the minimum performance criteria as specified in clause 4.3.1.12.3 or clause 4.3.2.11.3 is still met. The resulting level for the wanted signal at the input of the UUT is P_{min} . This signal level (P_{min}) is increased by the value provided in note 2 of the applicable table corresponding to the receiver category and type of equipment.

Step 4:

- The blocking signal at the UUT is set to the level provided in the table corresponding to the receiver category and type of equipment.
- If the performance criteria as specified in clause 4.3.1.12.3 or clause 4.3.2.11.3 are met then proceed to step 6.

Step 5:

- If the performance criteria as specified in clause 4.3.1.12.3 or clause 4.3.2.11.3 is not met, step 3 and step 4 shall be repeated after that the frequency of the blocking signal set in step 2 has been increased with a value equal to the Occupied Channel Bandwidth except:

- For the blocking frequency 2 380 MHz, where this frequency offset shall be less than or equal to 10 MHz. If this frequency offset is more than 7 MHz, the level of the wanted signal shall be increased by 3 dB.

- For the blocking frequency 2 503,5 MHz, where this frequency offset shall be less than or equal to 10 MHz. If this frequency offset is more than 7 MHz, the level of the wanted signal shall be decreased by 3 dB.

- If the performance criteria as specified in clause 4.3.1.12.3 or clause 4.3.2.11.3 is still not met, step 3 and step 4 shall be repeated after that the frequency of the blocking signal set in step 2 has been decreased with a value equal to the Occupied Channel Bandwidth except:

- For the blocking frequency 2 380 MHz, where this frequency offset shall be less than or equal to 10 MHz. If this frequency offset is more than 7 MHz, the level of the wanted signal shall be decreased by 3 dB.

- For the blocking frequency 2 503,5 MHz, where this frequency offset shall be less than or equal to 10 MHz. If this frequency offset is more than 7 MHz, the level of the wanted signal shall be increased by 3 dB.
- If the performance criteria as specified in clause 4.3.1.12.3 or clause 4.3.2.11.3 is still not met, the UUT fails to comply with the Receiver Blocking requirement and step 6 and step 7 are no longer required.
- It shall be recorded in the test report whether the shift of blocking frequencies as described in the present step was used.

Step 6:

- Repeat step 4 and step 5 for each remaining combination of frequency and level for the blocking signal as provided in the table corresponding to the receiver category and type of equipment.

Step 7:

- For non-FHSS equipment, repeat step 2 to step 6 with the UUT operating at the highest operating channel on which the blocking test has to be performed (see clause 5.4.11.1).

Step 8:

- It shall be assessed and recorded in the test report whether the UUT complies with the Receiver Blocking requirement.

14.4 Deviation From Test Standard

No deviation

14.5 Test Data

Please refer to the Attachment H.

15 Geo-location Capability

15.1 Standard Requirement

15.1.1 Requirement

ETSI EN 300 328 V2.2.2:2019 Clause 4.3.1.12

15.1.2 Definition

Geo-location capability is a feature of the equipment to determine its geographical location with the purpose to configure itself according to the regulatory requirements applicable at the geographical location where it operates.

The geo-location capability may be present in the equipment or in an external device (temporary) associated with the equipment operating at the same geographical location during the initial power up of the equipment. The geographical location may also be available in equipment already installed and operating at the same geographical location.

15.1.3 Requirements

The geographical location determined by the equipment as defined above, shall not be accessible to the user.

15.2 Test Result

This requirement only applies to equipment with geo-location capability as defined.

Note:

The Equipment without the geo-location capability, so no requirement for this test item.

16 Photographs – Test Setup

Radiated Spurious Emission (Below 1 GHz)



Radiated Spurious Emission (Above 1 GHz)



Attachment A-- RF Output Power Test Data

| Test Conditions: | | Continuous transmitting Mode | | | | |
|------------------|-----------------|------------------------------|--------------------------|------------------------|-------------|-------------|
| Rel. Humidity: | | 55% | | Pressure: | | 1010 hPa |
| Test Mode | Test Conditions | EIRP (dBm) | | | Limit (dBm) | Result |
| | | Low Channel (2412MHz) | Middle Channel (2442MHz) | High Channel (2472MHz) | | |
| 802.11 b | Tnom, Vnom | 13.87 | 13.4 | 12.88 | 20 | PASS |
| | Tmin, Vnom | 13.24 | 13.35 | 12.26 | | |
| | Tmax, Vnom | 13.46 | 13.23 | 12.69 | | |
| 802.11 g | Tnom, Vnom | 12.8 | 12.4 | 11.96 | | |
| | Tmin, Vnom | 12.36 | 12.26 | 11.56 | | |
| | Tmax, Vnom | 12.34 | 12.15 | 11.64 | | |
| 802.11 n(HT20) | Tnom, Vnom | 11.76 | 11.39 | 10.66 | | |
| | Tmin, Vnom | 10.88 | 11.34 | 10.29 | | |
| | Tmax, Vnom | 10.73 | 11.16 | 10.35 | | |

Remark:
 EIRP=A+G+Y
 G= 2.0dBi Y=0

Attachment B-- Power Spectral Density Test Data

| Test Conditions: 802.11 b/g/n TX mode | | | | Temperature: 25°C | |
|--|--|--------------------------|-------|---------------------------|--------|
| Test Voltage: AC 230V | | Rel.Humidity: 55% | | Pressure: 1010 hPa | |
| 802.11b/g/n | | | | | |
| Test Mode | EIRP Spectral Power Density (dBm / MHz) | | | Limit (dBm / MHz) | Result |
| | CH 01 | CH 07 | CH 13 | | |
| 802.11b | 8.69 | 8.18 | 7.75 | 10 | Pass |
| 802.11g | 4.58 | 4.12 | 3.79 | | |
| 802.11n(HT20) | 3.52 | 3.08 | 2.47 | | |
| Remark: EIRP=A+G+Y G=2.0dBi Y=0 | | | | | |
| the test plots please refer the follow page. | | | | | |

802.11 B Mode

Low Channel 2412 MHz

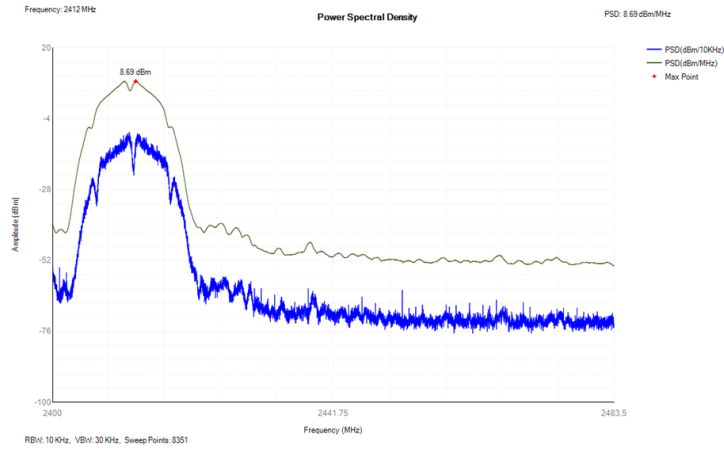

Middle Channel 2442 MHz

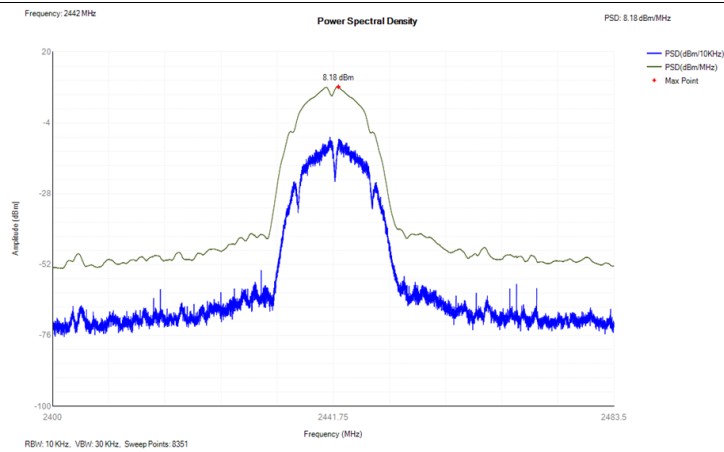

High Channel 2472 MHz

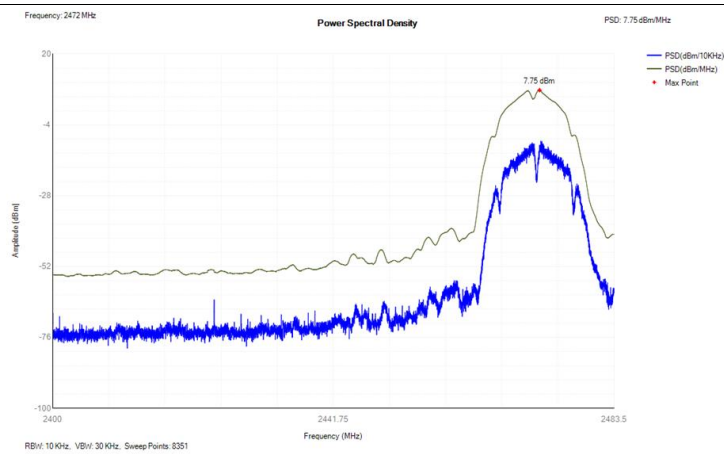

802.11 N(HT20) Mode

Low Channel 2412 MHz

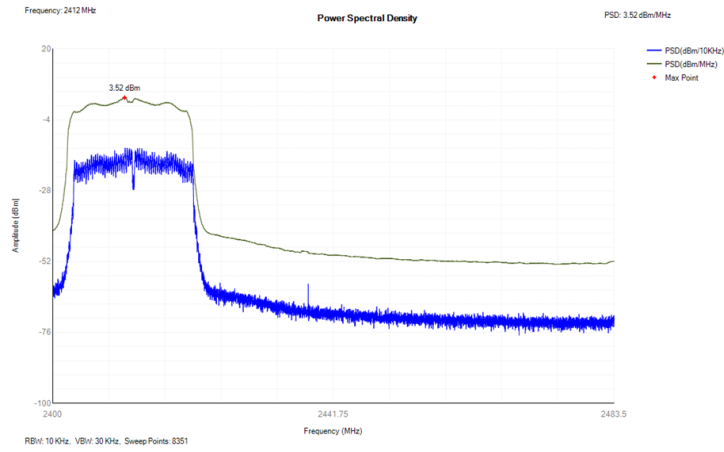

Middle Channel 2442 MHz

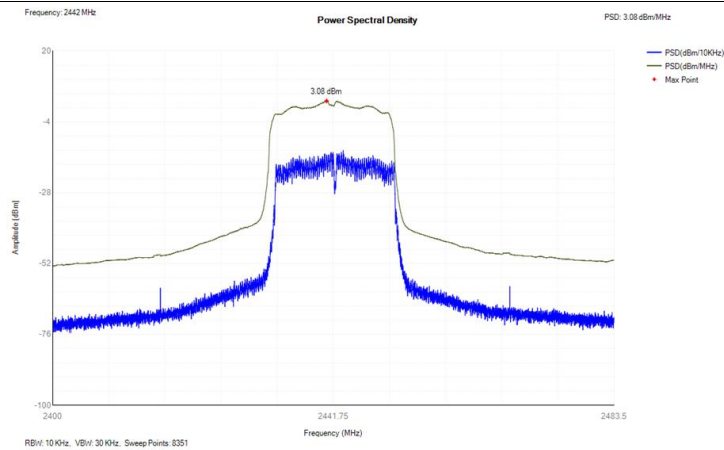

High Channel 2472 MHz

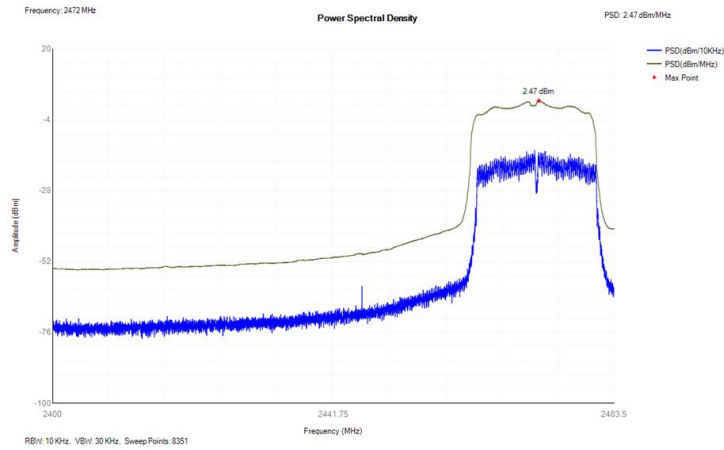

Attachment C-- Adaptivity Test Data

| Condition | Mode | Frequency (MHz) | Antenna | AWGN Level (dBm) | CW Level (dBm) | Short Control Width (ms) | Short Control Ratio(%) | Limit (%) | Verdict |
|-----------|---------|-----------------|---------|------------------|----------------|--------------------------|------------------------|-----------|---------|
| NVNT | b | 2412 | Ant1 | -65.87 | -35 | 1.95 | 3.9 | <=10 | Pass |
| NVNT | b | 2472 | Ant1 | -64.88 | -35 | 1.3 | 2.6 | <=10 | Pass |
| NVNT | g | 2412 | Ant1 | -64.8 | -35 | 0.65 | 1.3 | <=10 | Pass |
| NVNT | g | 2472 | Ant1 | -63.96 | -35 | 1.3 | 2.6 | <=10 | Pass |
| NVNT | n(HT20) | 2412 | Ant1 | -63.76 | -35 | 2.6 | 5.2 | <=10 | Pass |
| NVNT | n(HT20) | 2472 | Ant1 | -62.66 | -35 | 0 | 0 | <=10 | Pass |

Adaptivity NVNT b 2412MHz

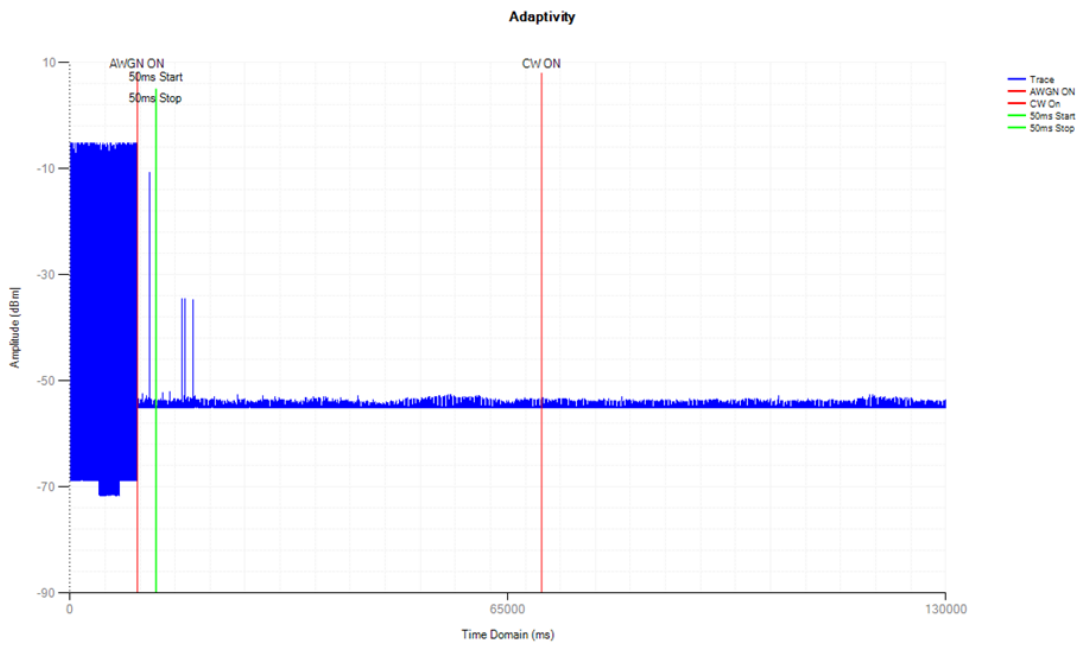

Control Signal NVNT b 2412MHz

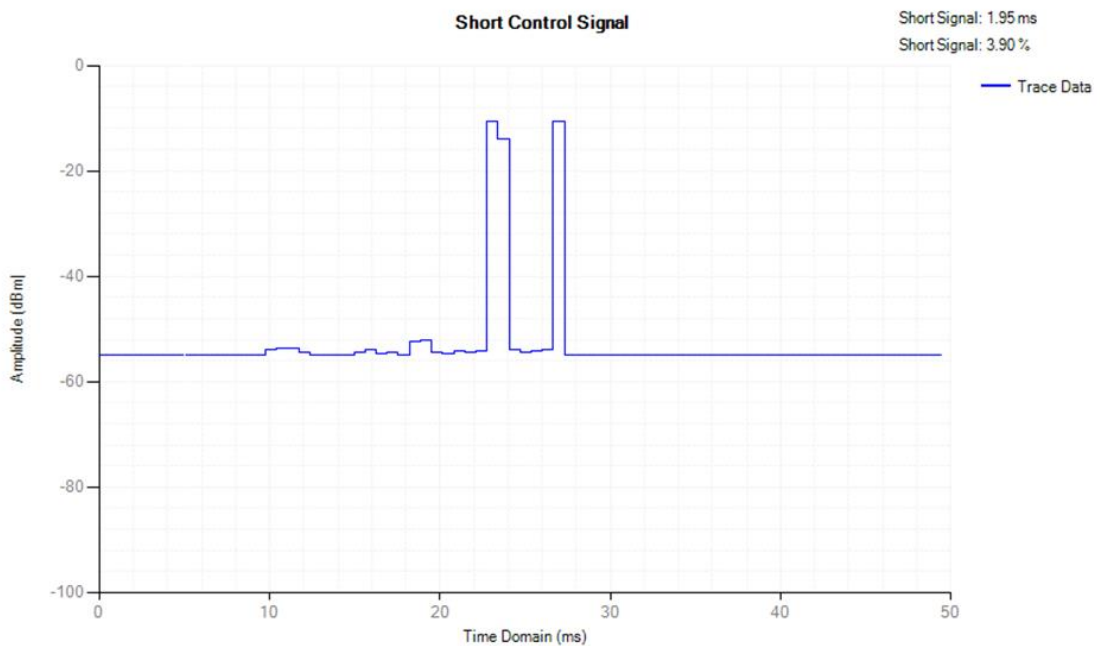

Adaptivity NVNT b 2472MHz

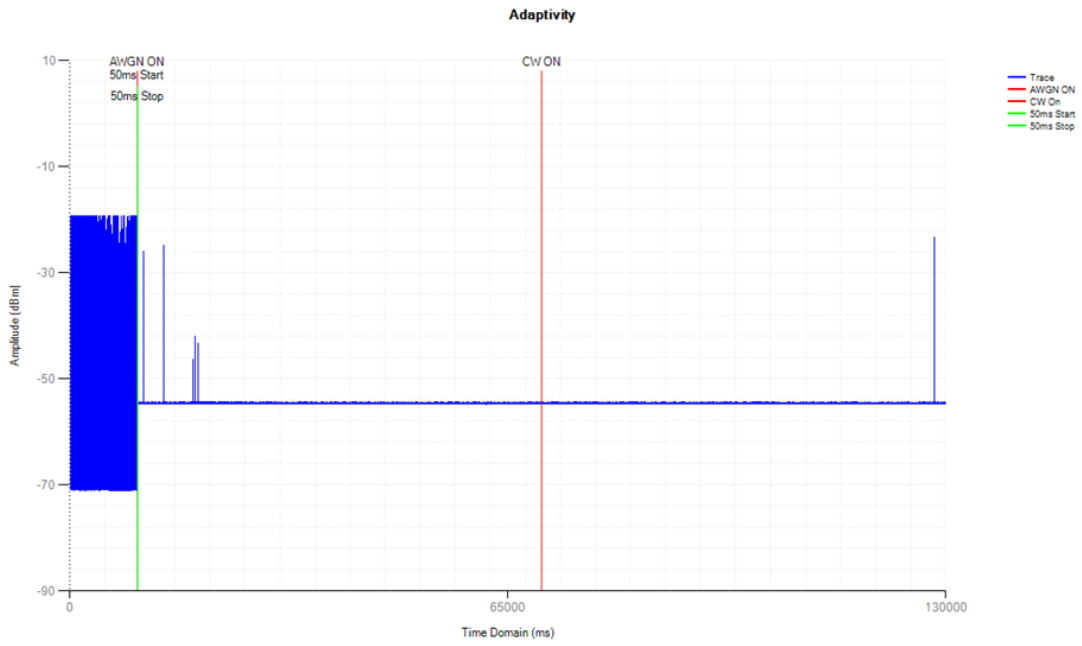

Control Signal NVNT b 2472MHz

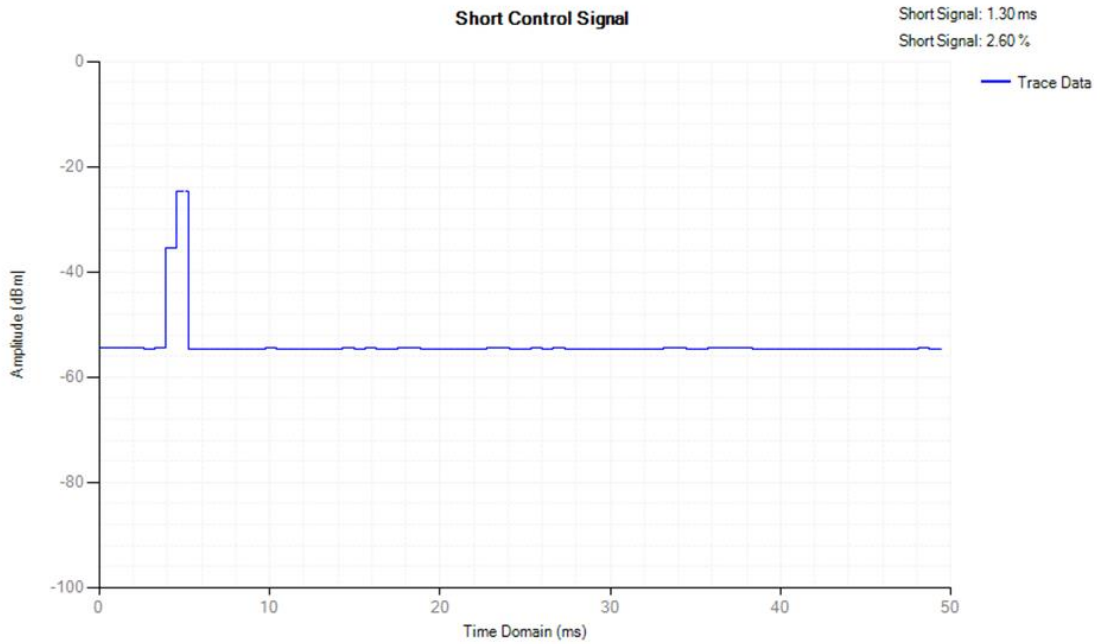

Adaptivity NVNT g 2412MHz

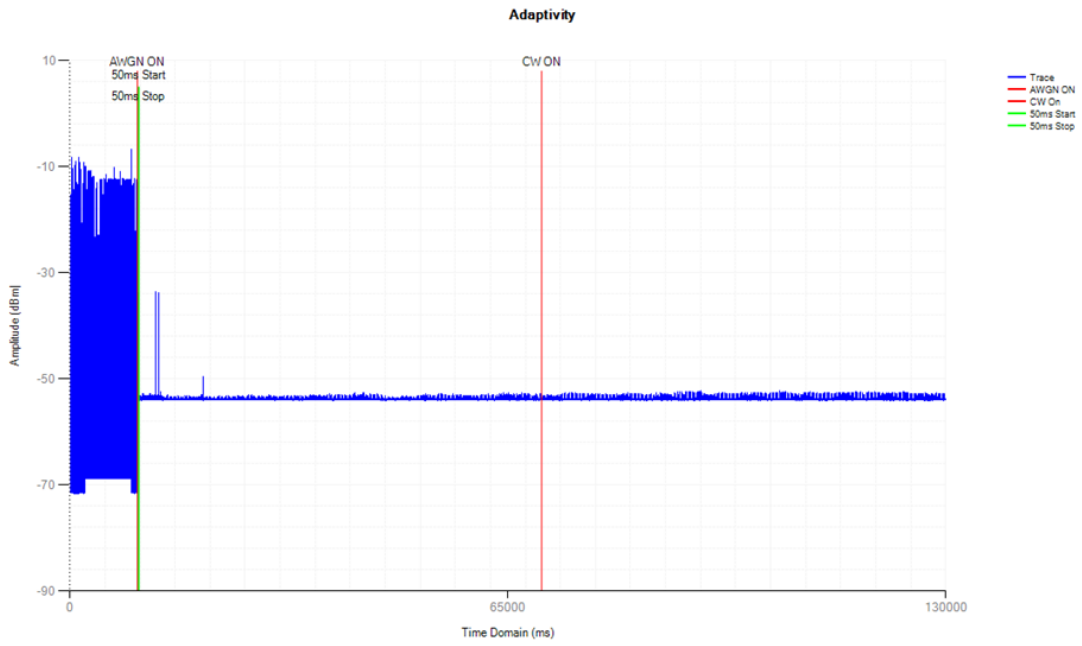

Control Signal NVNT g 2412MHz

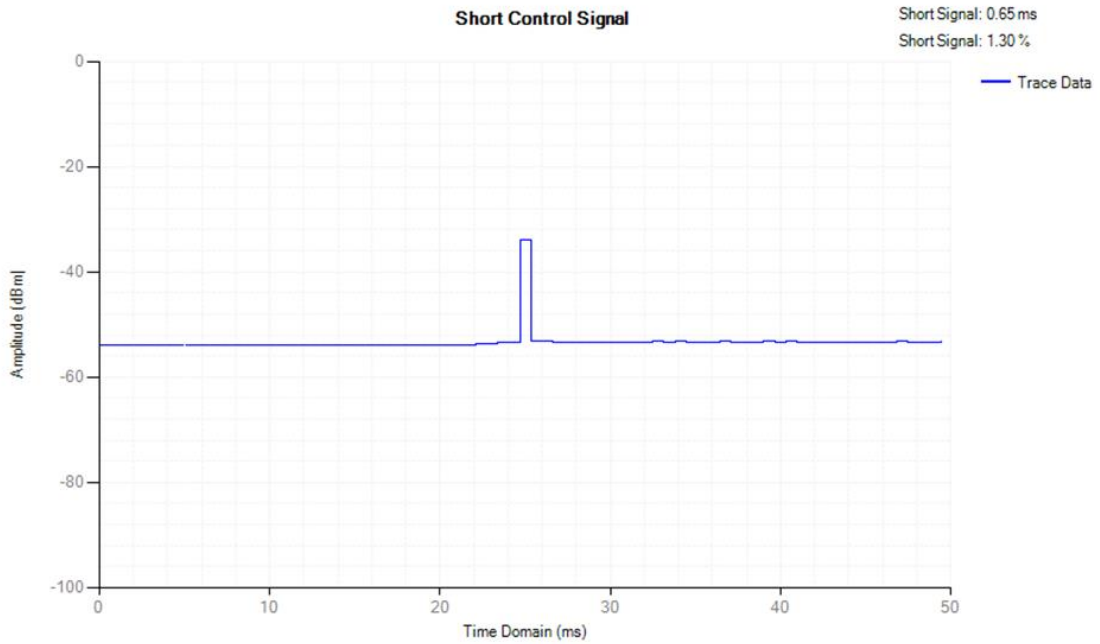

Adaptivity NVNT g 2472MHz

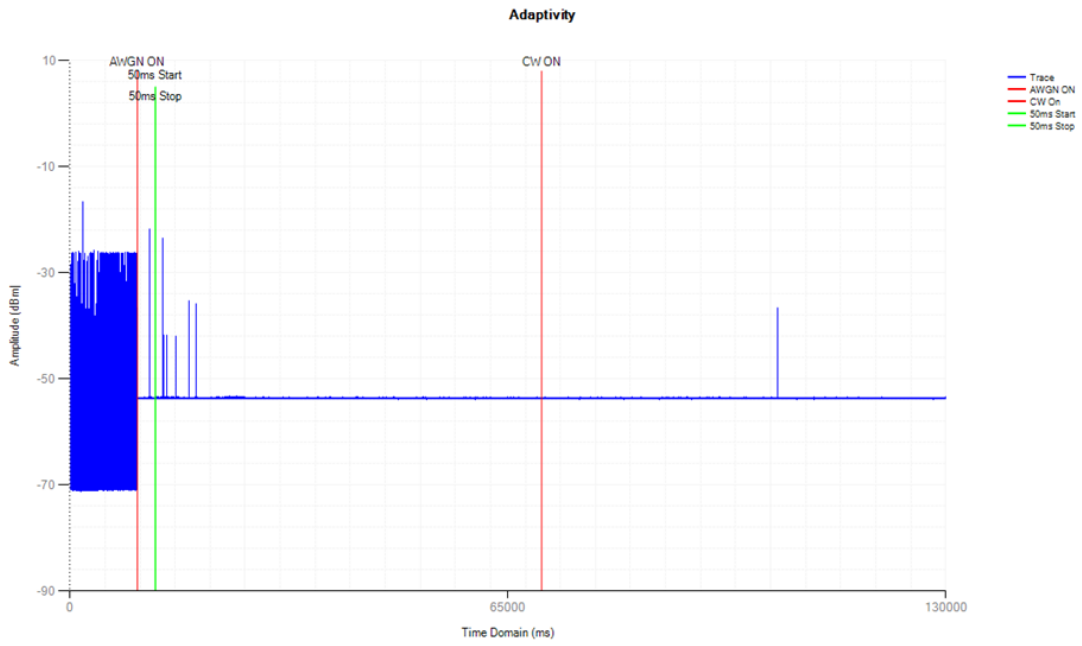

Control Signal NVNT g 2472MHz

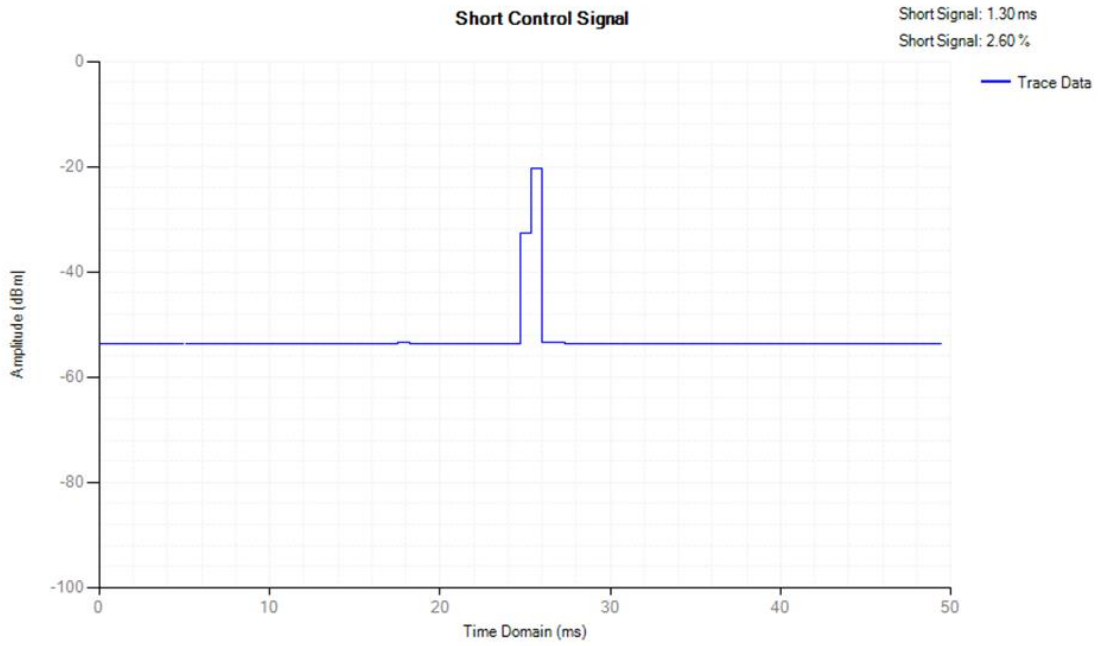

Adaptivity NVNT n(HT20) 2412MHz

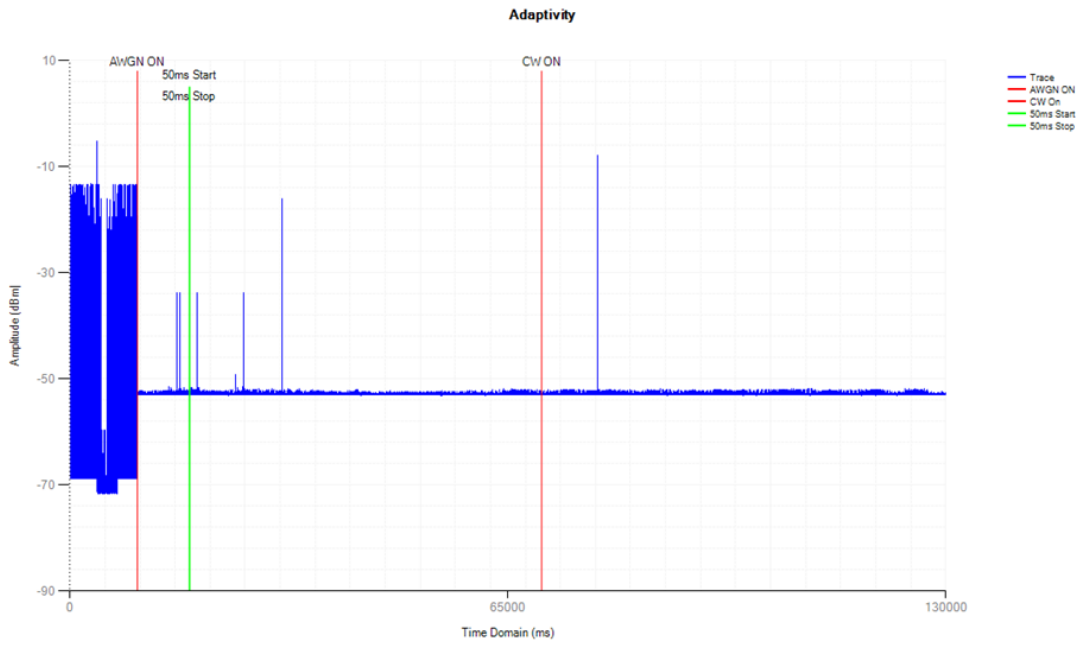

Control Signal NVNT n(HT20) 2412MHz

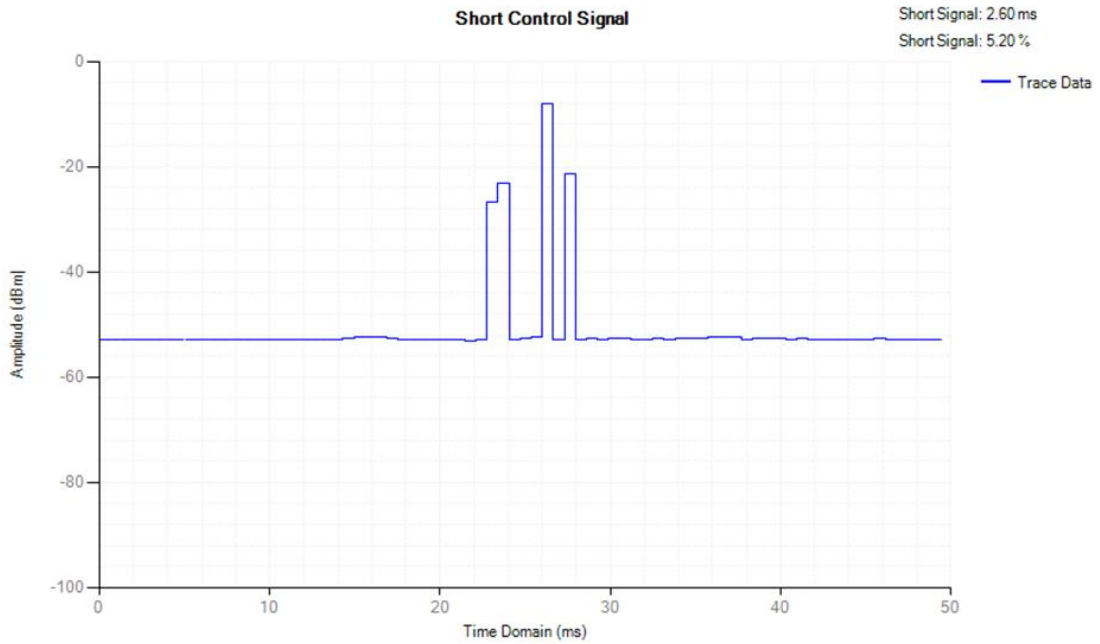

Adaptivity NVNT n(HT20) 2472MHz

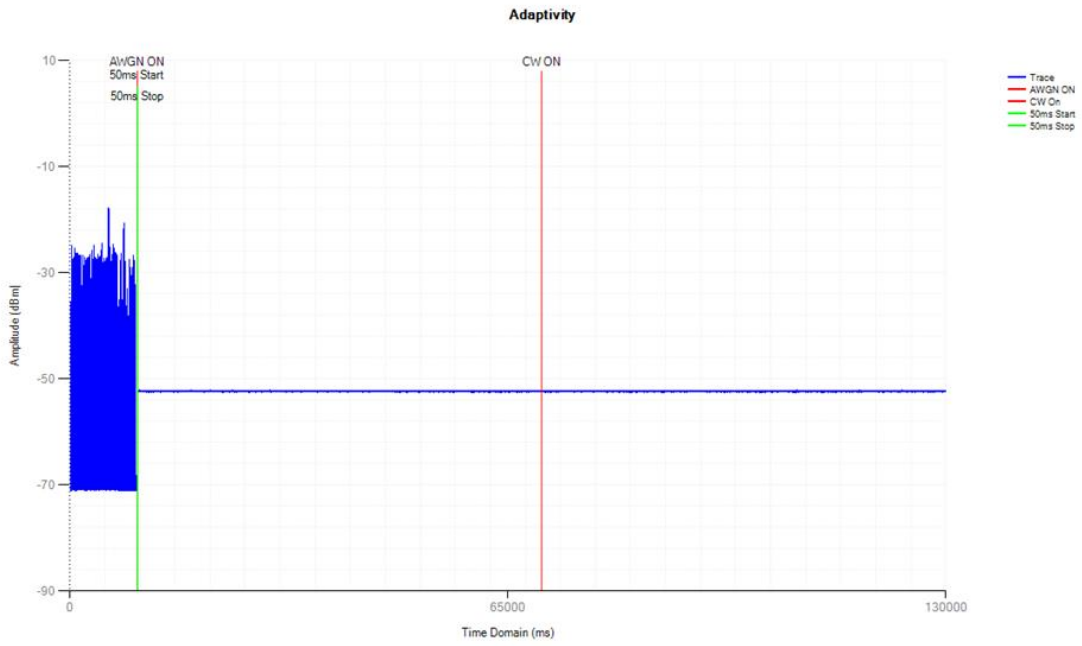

Control Signal NVNT n(HT20) 2472MHz

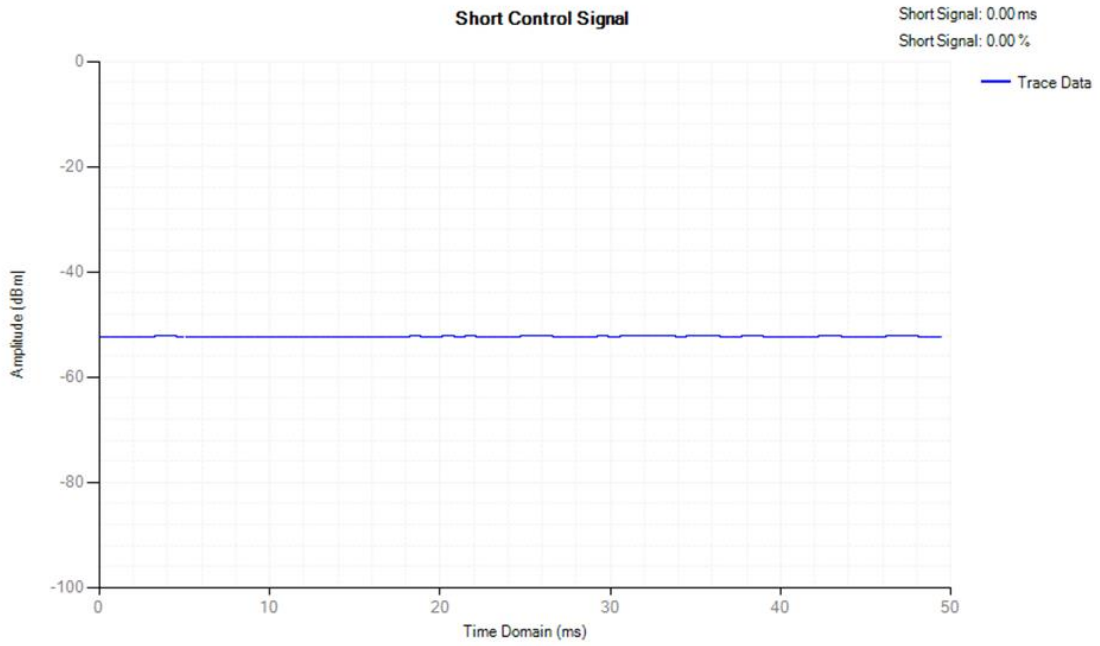

| Condition | Mode | Frequency (MHz) | Antenna | Max COT (ms) | Limit COT (ms) | Min Idle Time (ms) | Limit Idle Time (ms) | Verdict |
|-----------|---------|-----------------|---------|--------------|----------------|--------------------|----------------------|---------|
| NVNT | b | 2412 | Ant1 | 6.408 | <=13 | 0.07 | >0.018 | Pass |
| NVNT | b | 2472 | Ant1 | 1.324 | <=13 | 0.111 | >0.018 | Pass |
| NVNT | g | 2412 | Ant1 | 0.252 | <=13 | 0.043 | >0.018 | Pass |
| NVNT | g | 2472 | Ant1 | 1.153 | <=13 | 0.075 | >0.018 | Pass |
| NVNT | n(HT20) | 2412 | Ant1 | 0.233 | <=13 | 0.061 | >0.018 | Pass |
| NVNT | n(HT20) | 2472 | Ant1 | 0.519 | <=13 | 0.061 | >0.018 | Pass |

COT NVNT b 2412MHz

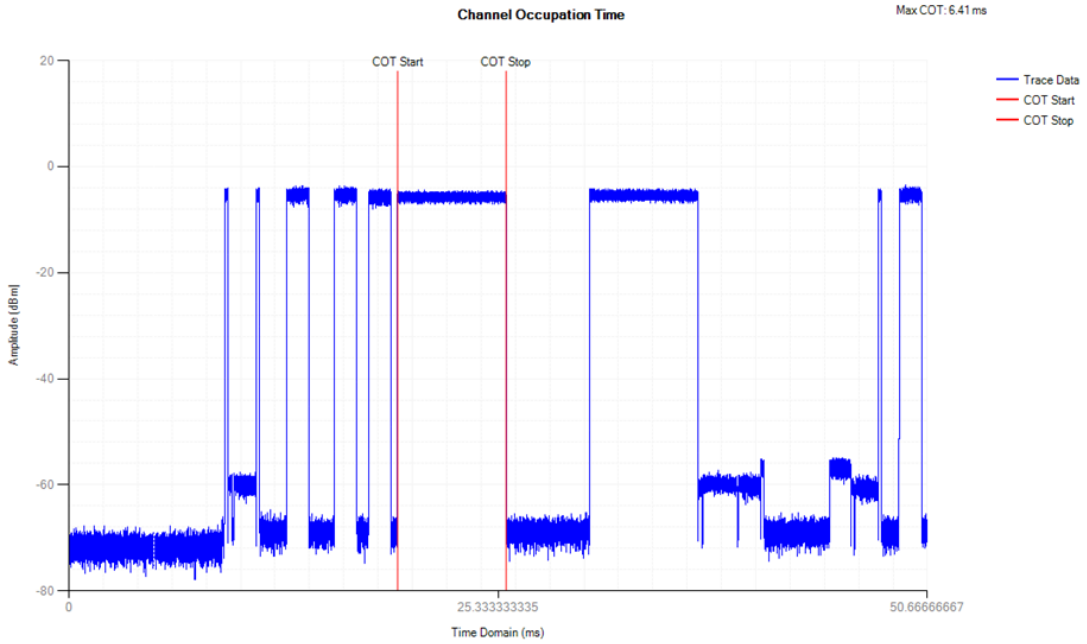

Idle NVNT b 2412MHz

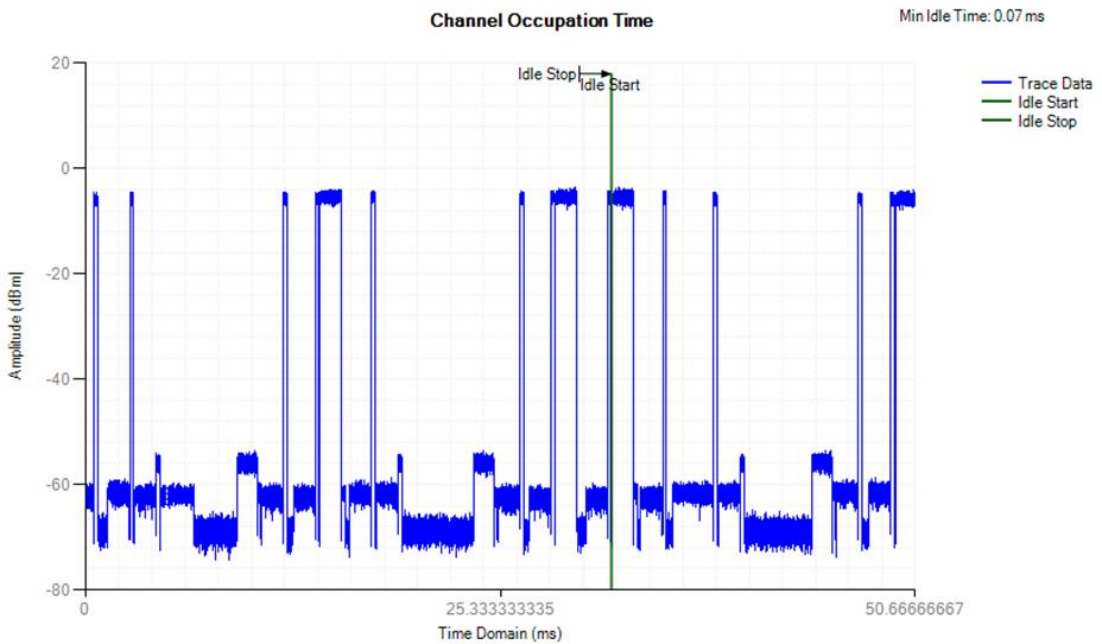

COT NVNT b 2472MHz

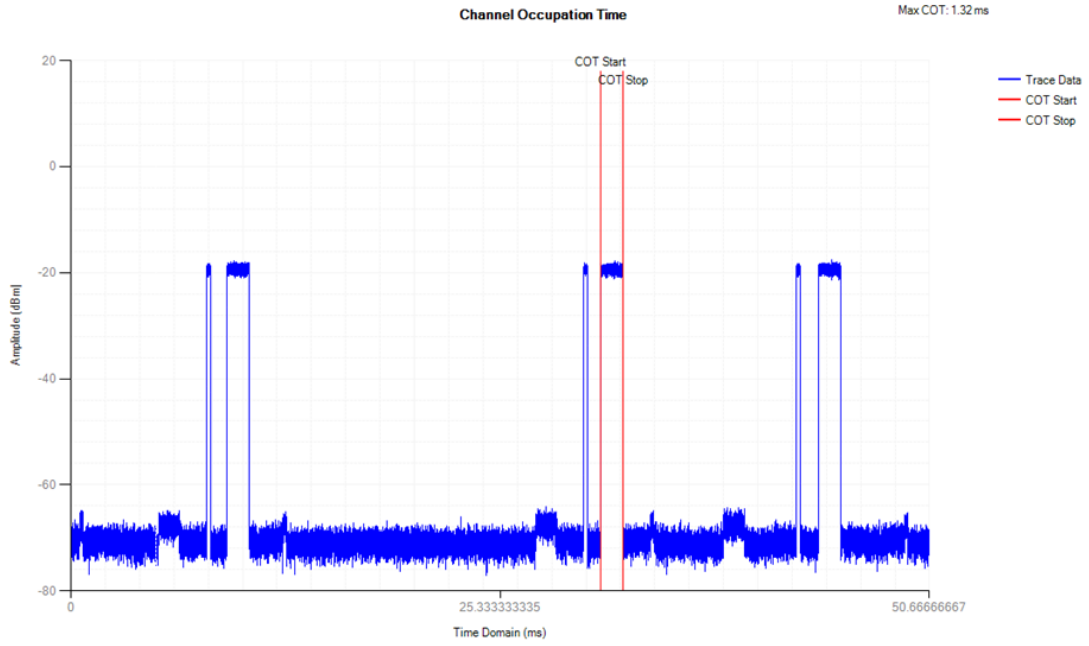

Idle NVNT b 2472MHz

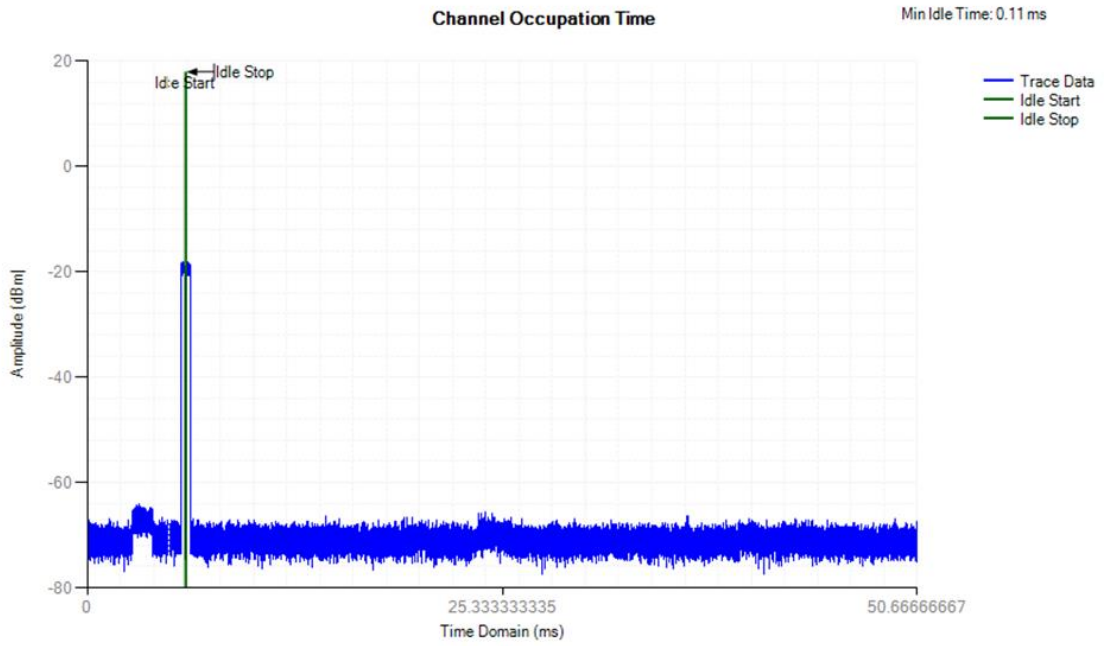

COT NVNT g 2412MHz

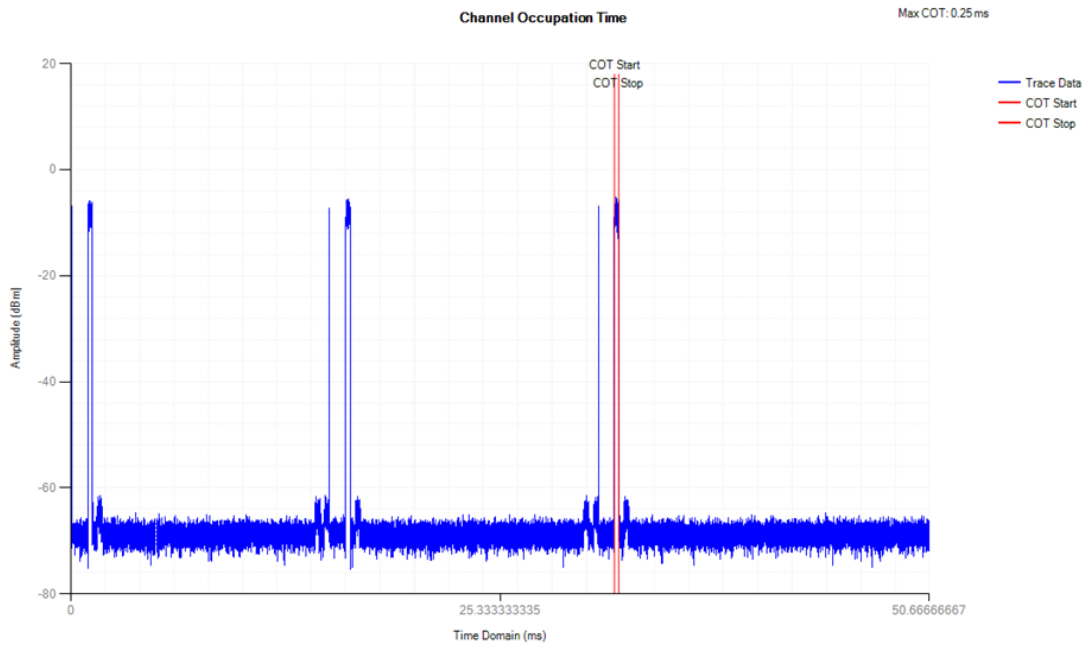

Idle NVNT g 2412MHz

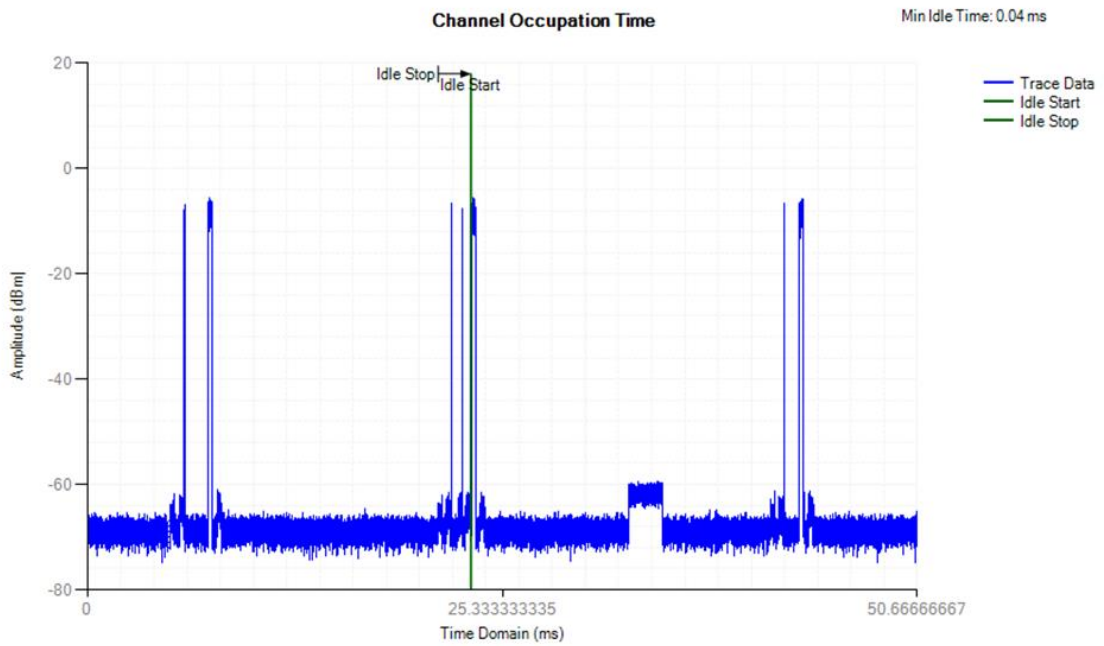

COT NVNT g 2472MHz

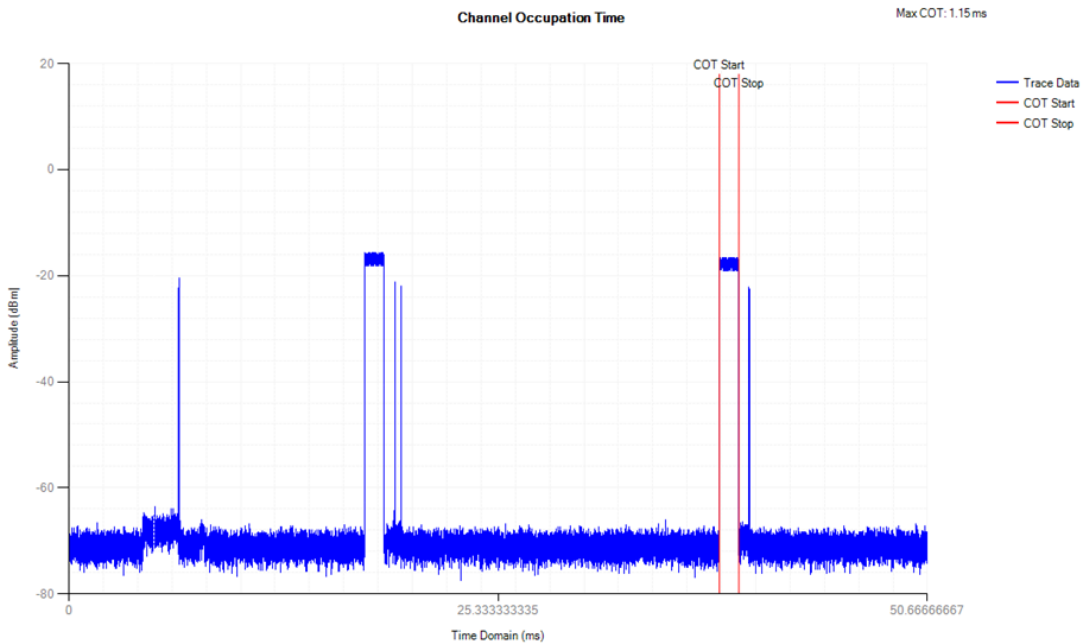

Idle NVNT g 2472MHz

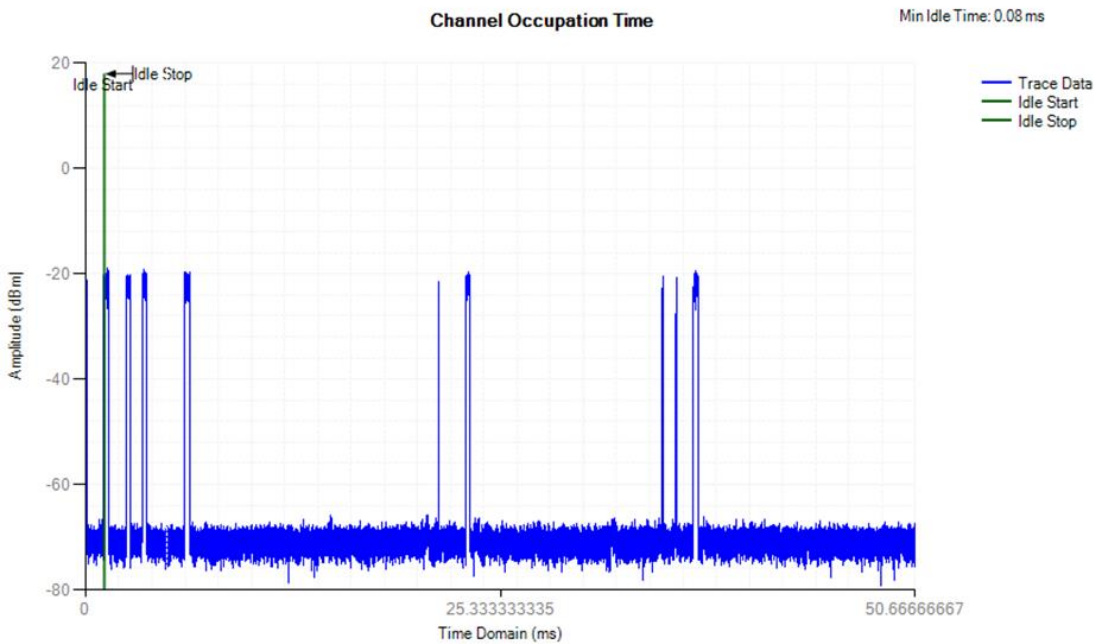

COT NVNT n(HT20) 2412MHz

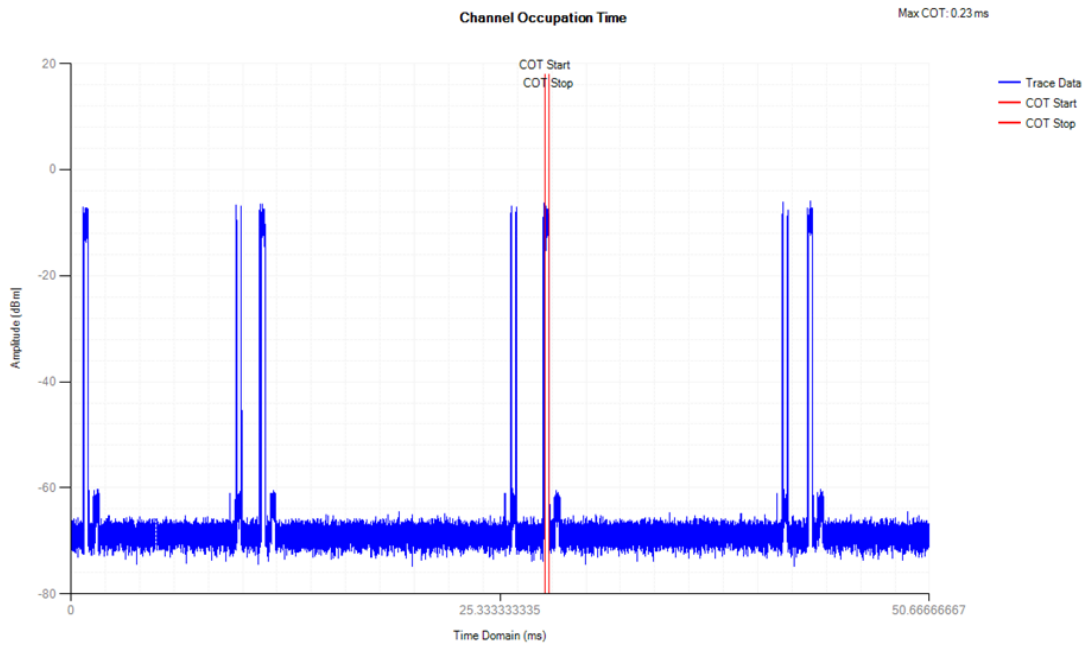

Idle NVNT n(HT20) 2412MHz

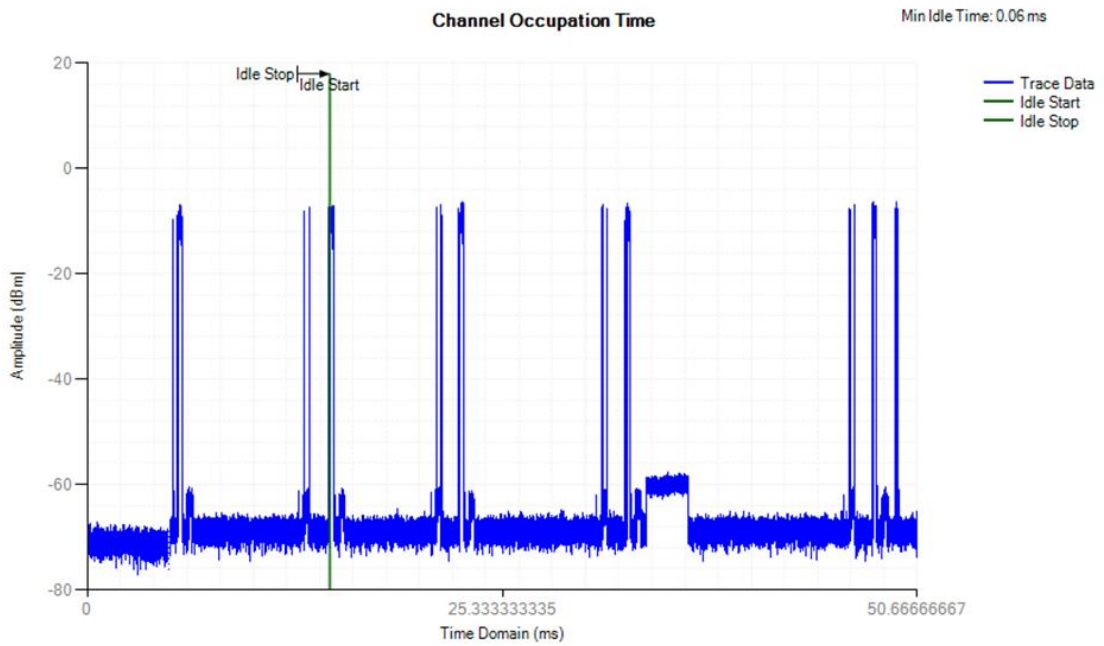

COT NVNT n(HT20) 2472MHz

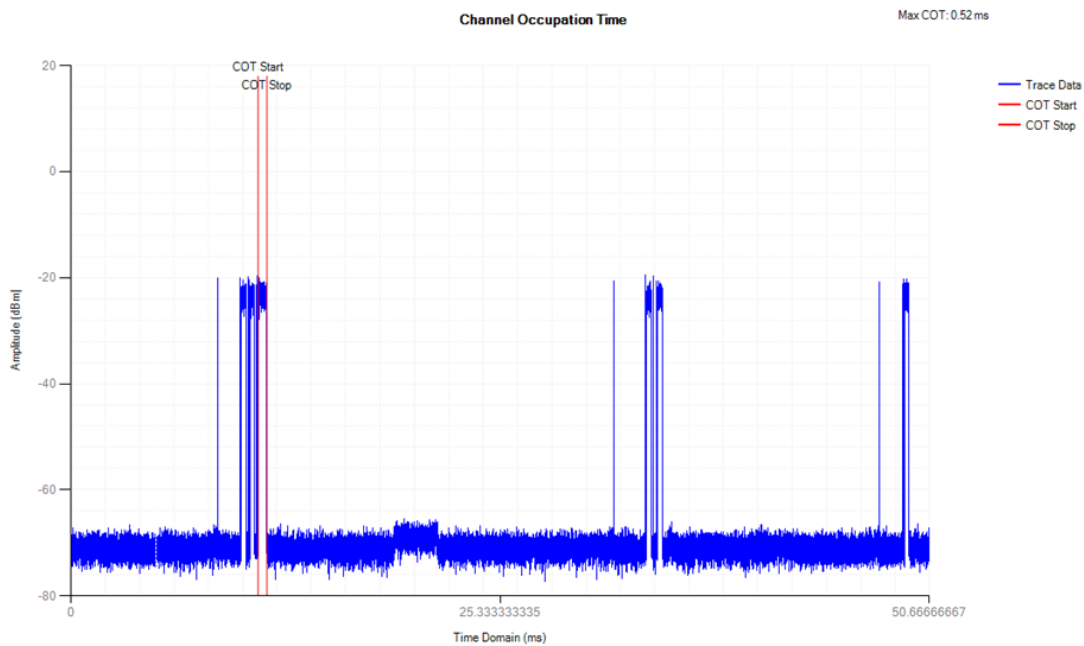

Idle NVNT n(HT20) 2472MHz

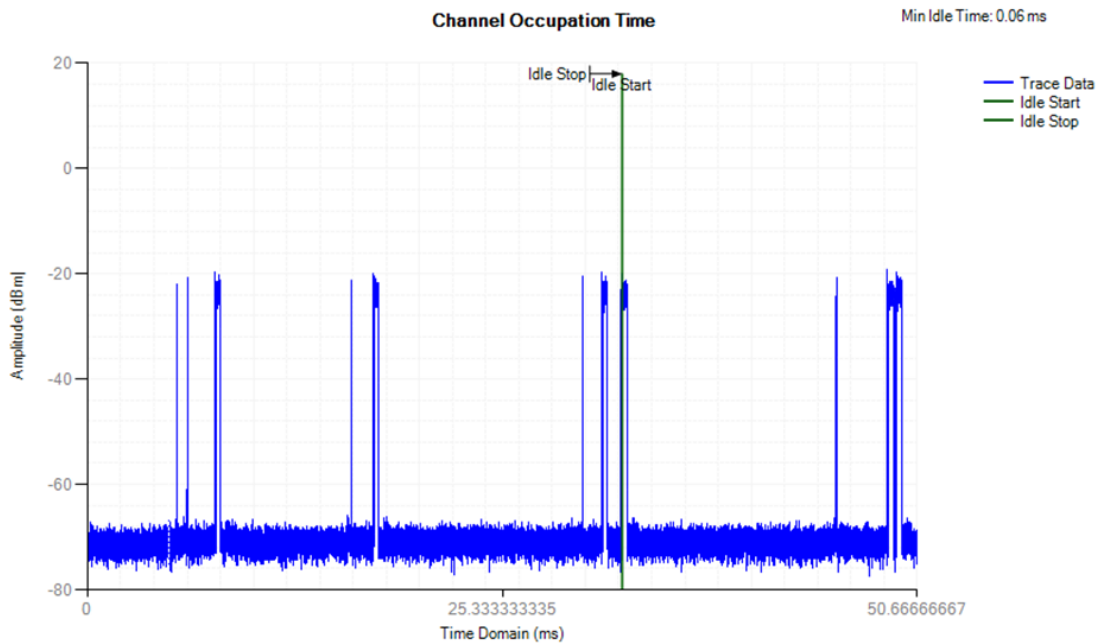

Attachment D--Occupied Channel Bandwidth Test Data

| Temperature: | 25 °C | Relative Humidity: | 55% | | | |
|--|------------------------|---------------------------|---|---|----------------|--------|
| Test Voltage: | AC 230V | Pressure: | 1010 hPa | | | |
| Test Mode: | TX Mode | | | | | |
| Test Data | | | | | | |
| Mode | Frequen cy (MHz) | 99% OBW (MHz) | F _L Measured Frequency (MHz) | F _H Measured Frequency (MHz) | Limit (MHz) | Result |
| 802.11b | 2412 | 11.876 | 2406.098 | / | >2400 | PASS |
| | 2472 | 11.994 | / | 2478.038 | <2483.5 | PASS |
| 802.11g | 2412 | 16.415 | 2403.808 | / | >2400 | PASS |
| | 2472 | 16.426 | / | 2480.233 | <2483.5 | PASS |
| 802.11 n(HT20) | 2412 | 17.59 | 2403.221 | / | >2400 | PASS |
| | 2472 | 17.594 | / | 2480.819 | <2483.5 | PASS |
| the test plots please refer the follow page. | | | | | | |

802.11B Mode 2412 MHz

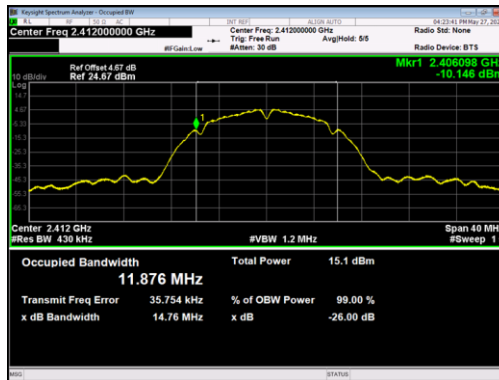

802.11B Mode 2472 MHz

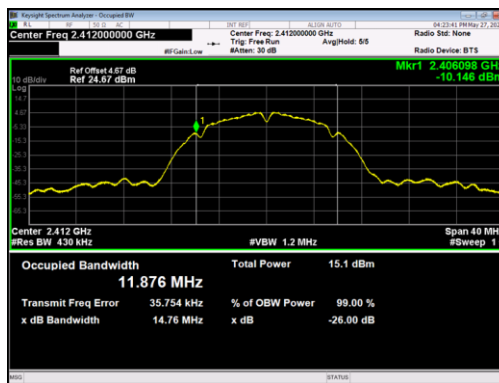

802.11G Mode 2412 MHz

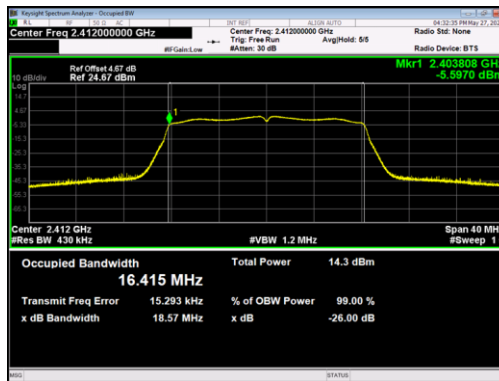

802.11G Mode 2472MHz

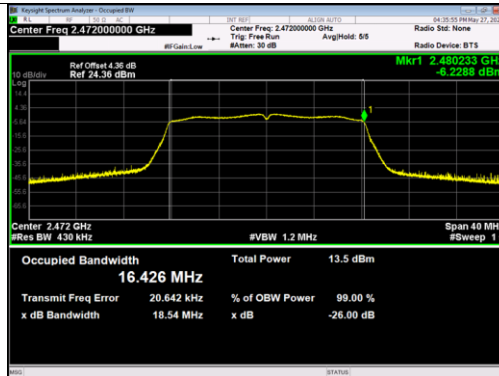

802.11N(HT20) Mode 2412 MHz

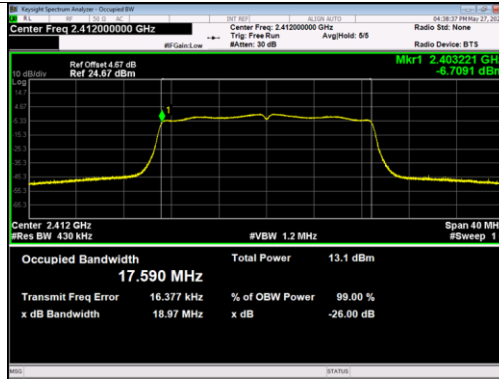

802.11N(HT20) Mode 2472 MHz

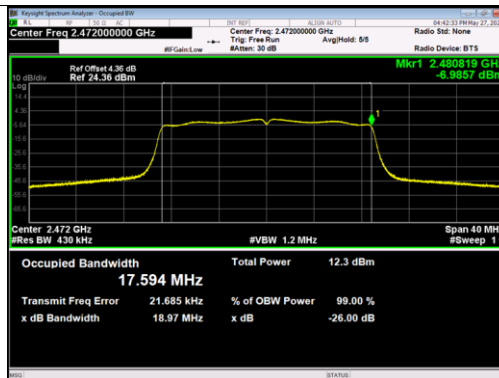

Attachment E-- Transmitter unwanted emission in the OOB domain Test Data

| | | | |
|---------------|---------------|--------------------|----------|
| Temperature: | 25 °C | Relative Humidity: | 55% |
| Test Voltage: | AC 230V | Pressure: | 1010 hPa |
| Test Mode: | 802.11 B Mode | | |

Test Data

Remark: only show the worst test data, the test plots is as follows.

Low Channel 2412MHz

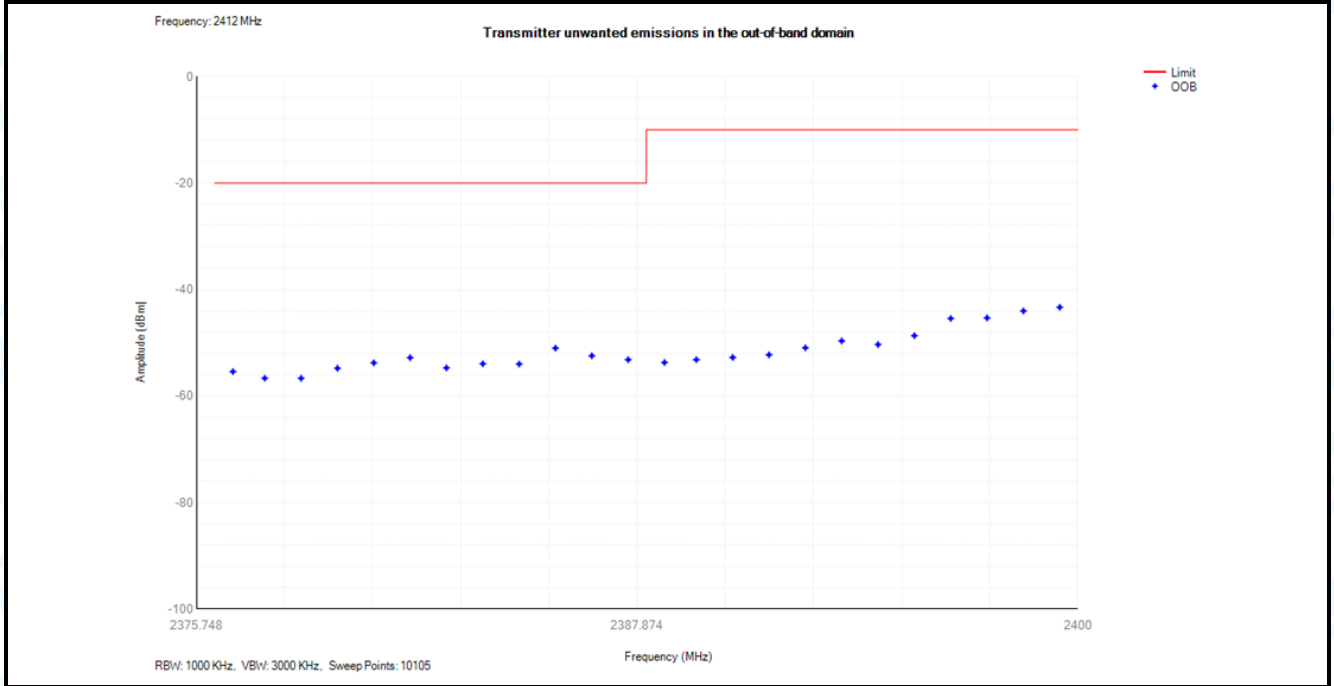

High Channel 2472MHz

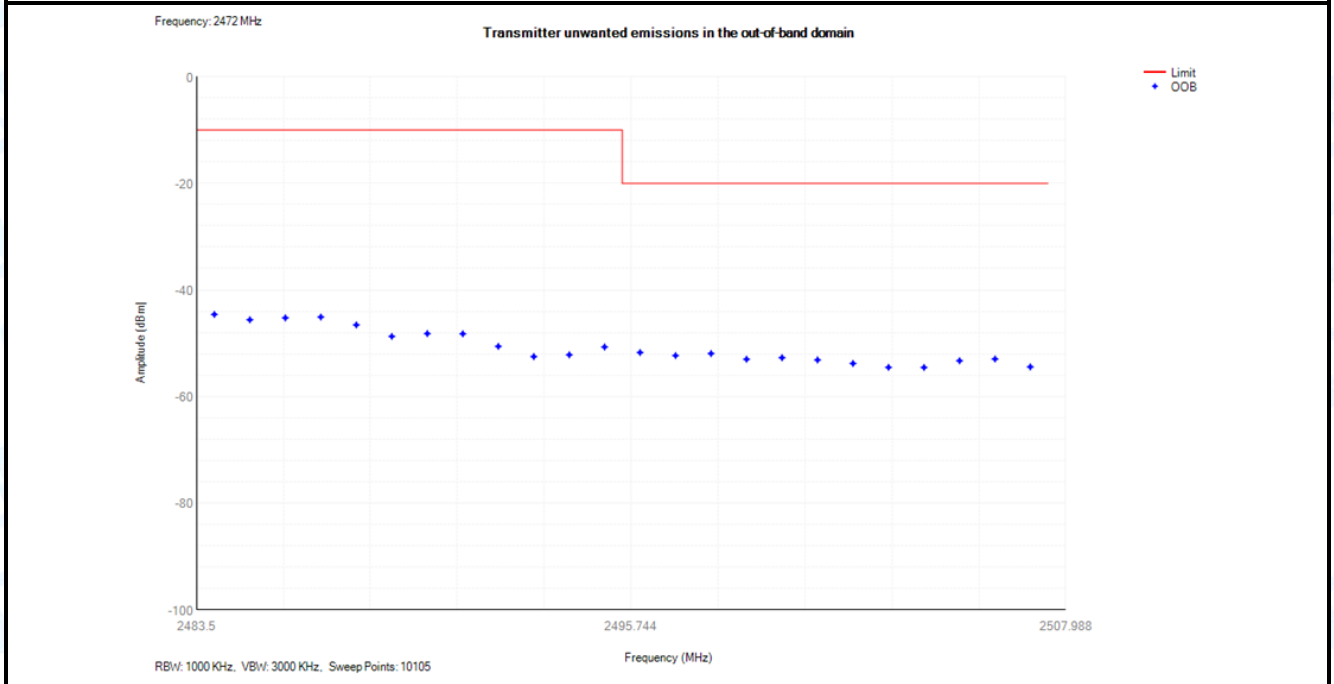

| | | | |
|----------------------|---------------|---------------------------|----------|
| Temperature: | 25 °C | Relative Humidity: | 55% |
| Test Voltage: | AC 230V | Pressure: | 1010 hPa |
| Test Mode: | 802.11 G Mode | | |

Test Data

Remark: only show the worst test data, the test plots is as follows.

Low Channel 2412MHz

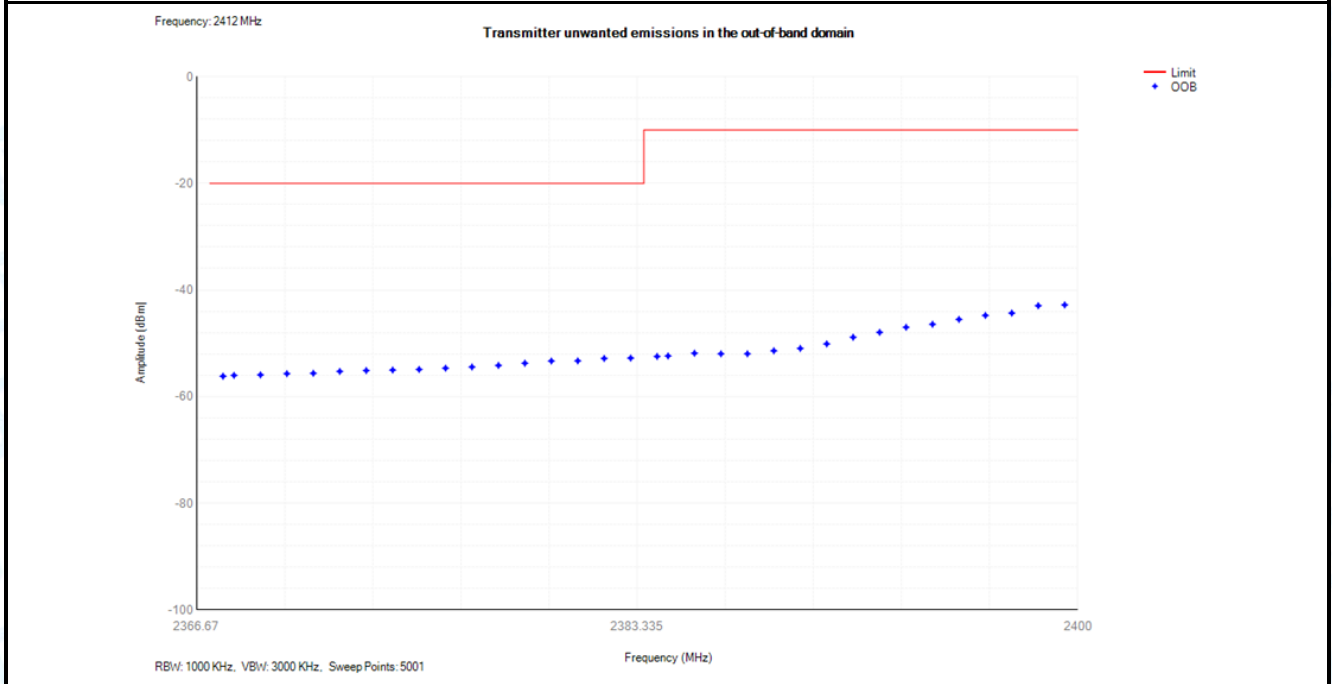

High Channel 2472MHz

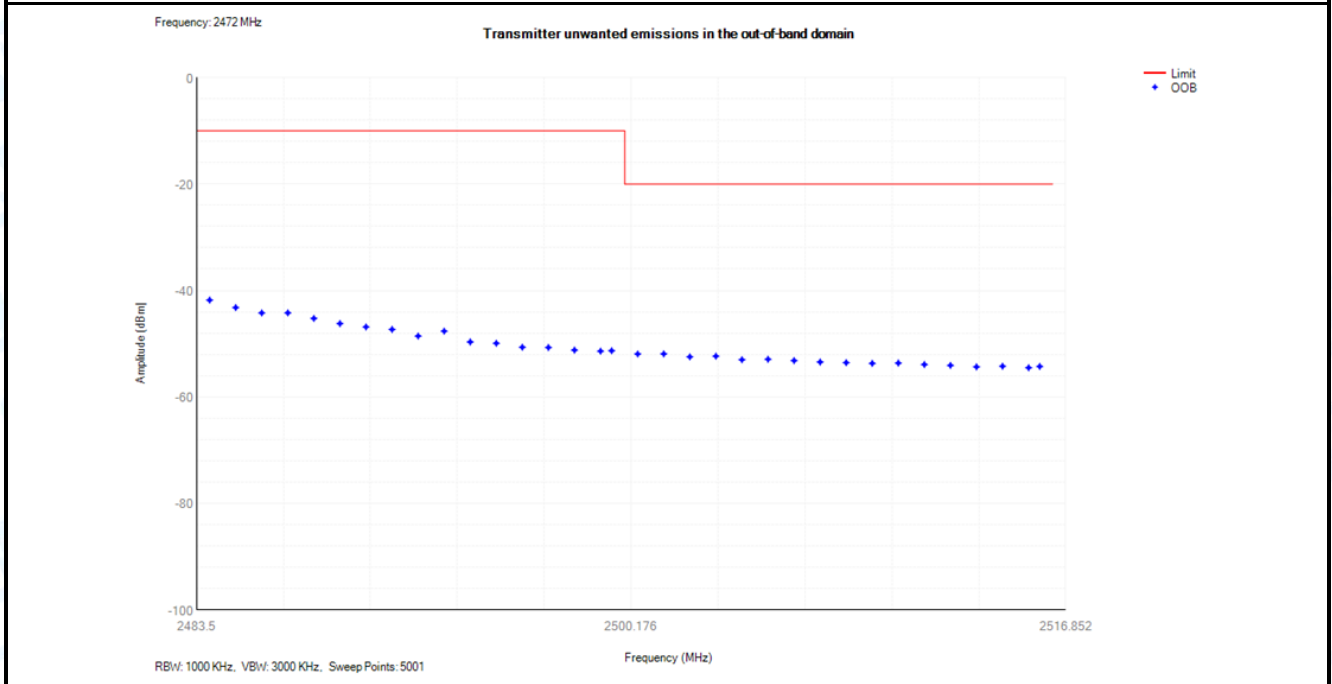

| | | | |
|----------------------|---------------------|---------------------------|----------|
| Temperature: | 25 °C | Relative Humidity: | 55% |
| Test Voltage: | AC 230V | Pressure: | 1010 hPa |
| Test Mode: | 802.11 N(HT20) Mode | | |

Test Data

Remark: only show the worst test data, the test plots is as follows.

Low Channel 2412MHz

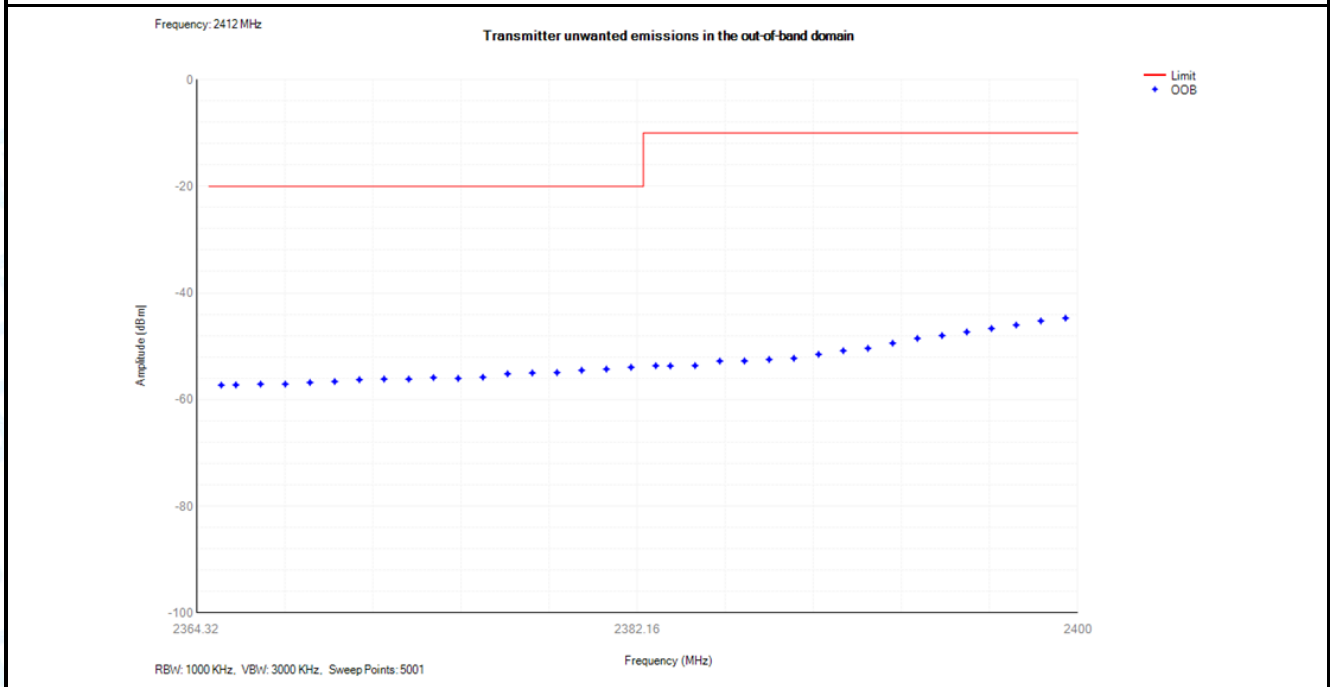

High Channel 2472MHz

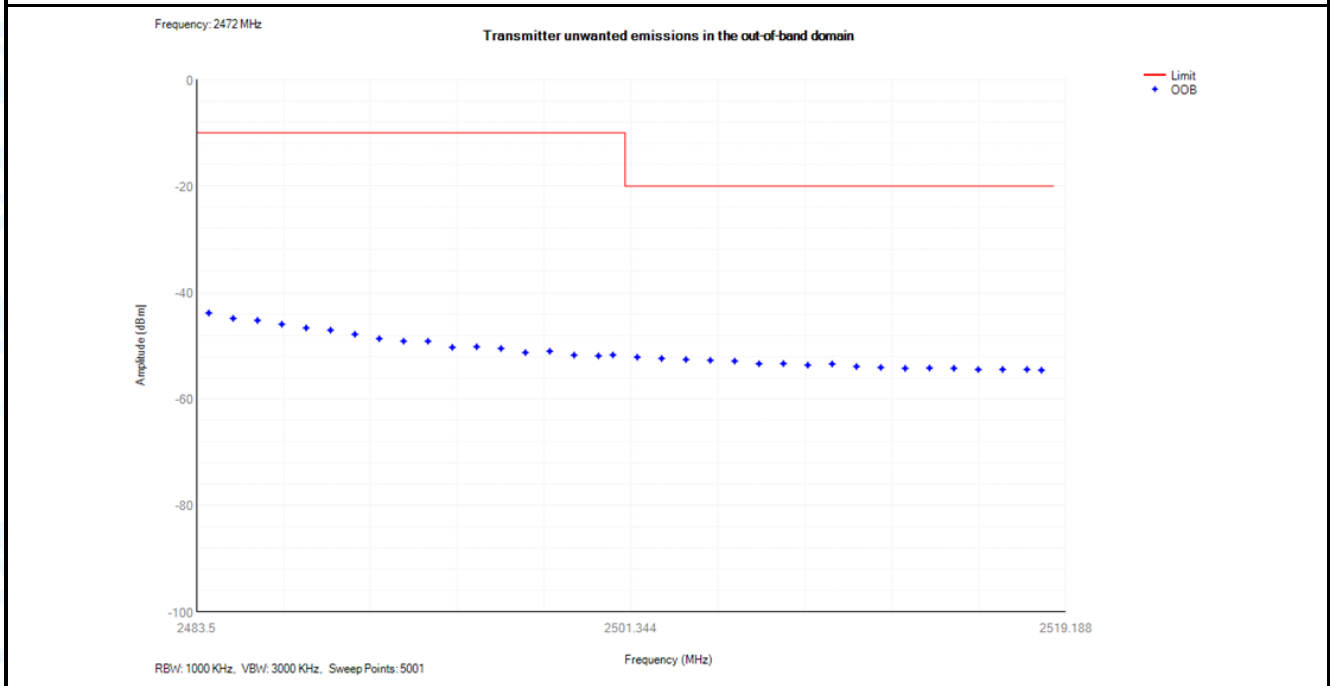

Attachment F-- Transmitter unwanted emissions in the spurious domain Test Data

(1) Below 1 G

| | | | |
|---------------|---------------------------------------|--------------------|-----|
| Temperature: | 25 °C | Relative Humidity: | 55% |
| Test Voltage: | AC 230V | | |
| Ant. Pol. | Horizontal | | |
| Test Mode: | TX B Mode 2412MHz | | |
| Remark: | Only showed the worst mode test data. | | |

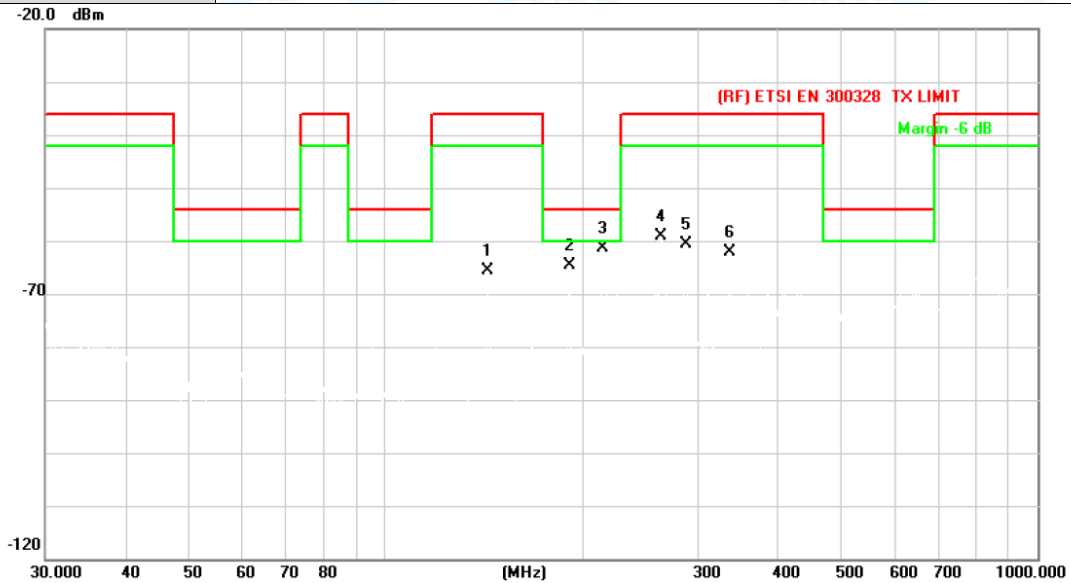

| No. | Mk. | Freq. MHz | Reading Level dBm | Correct Factor dB | Measure- ment dBm | Limit dBm | Over dB | Detector |
|-----|-----|--------------|-------------------------|-------------------------|-------------------------|--------------|------------|----------|
| 1 | | 143.3260 | -55.32 | -10.23 | -65.55 | -36.00 | -29.55 | peak |
| 2 | | 191.0738 | -57.33 | -7.32 | -64.65 | -54.00 | -10.65 | peak |
| 3 | * | 215.2677 | -57.75 | -3.59 | -61.34 | -54.00 | -7.34 | peak |
| 4 | | 263.8190 | -58.77 | -0.42 | -59.19 | -36.00 | -23.19 | peak |
| 5 | | 289.0020 | -54.36 | -6.25 | -60.61 | -36.00 | -24.61 | peak |
| 6 | | 337.2155 | -55.21 | -6.90 | -62.11 | -36.00 | -26.11 | peak |

Remark:

1. Corr. = Antenna Factor (dB/m) + Cable Loss (dB)
2. Margin (dB) = Peak(dBm) - Limit (dBm)

| | | | |
|----------------------|---------------------------------------|---------------------------|-----|
| Temperature: | 25 °C | Relative Humidity: | 55% |
| Test Voltage: | AC 230V | | |
| Ant. Pol. | Vertical | | |
| Test Mode: | TX B Mode 2412MHz | | |
| Remark: | Only showed the worst mode test data. | | |

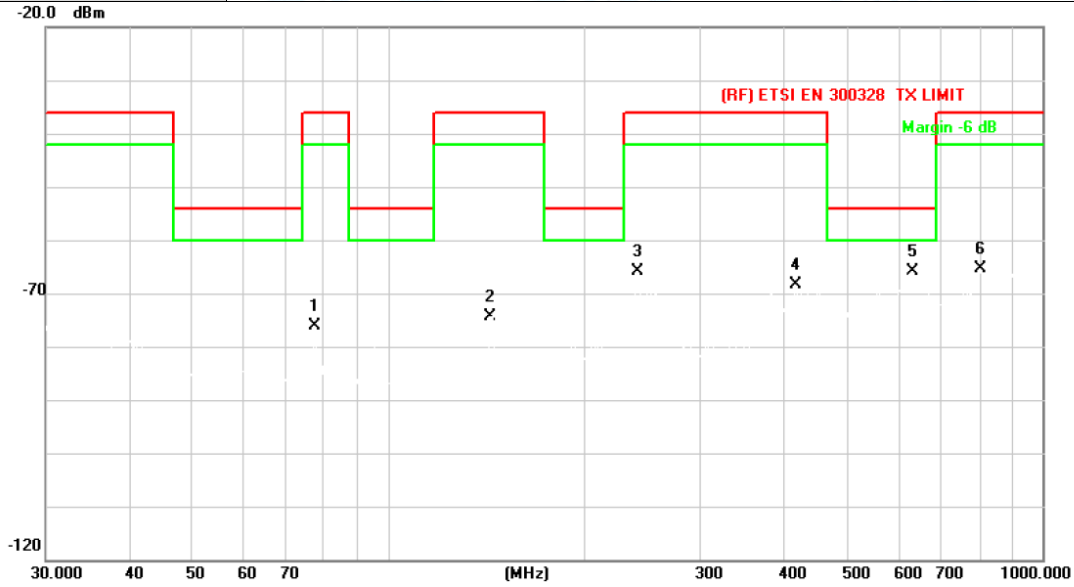

| No. | Mk. | Freq. MHz | Reading Level dBm | Correct Factor dB | Measurement dBm | Limit dBm | Over dB | Detector |
|-----|-----|--------------|-------------------------|-------------------------|--------------------|--------------|------------|----------|
| 1 | | 77.3212 | -64.31 | -11.82 | -76.13 | -36.00 | -40.13 | peak |
| 2 | | 143.3261 | -66.58 | -7.77 | -74.35 | -36.00 | -38.35 | peak |
| 3 | | 240.8304 | -58.27 | -7.52 | -65.79 | -36.00 | -29.79 | peak |
| 4 | | 419.1081 | -65.94 | -2.41 | -68.35 | -36.00 | -32.35 | peak |
| 5 | * | 633.9073 | -67.56 | 1.78 | -65.78 | -54.00 | -11.78 | peak |
| 6 | | 804.6028 | -69.26 | 3.99 | -65.27 | -36.00 | -29.27 | peak |

Remark:

1. Corr. = Antenna Factor (dB/m) + Cable Loss (dB)

2. Margin (dB) = Peak(dBm) - Limit (dBm)

(2) Above 1 GHz

| | | | |
|----------------------|--|---------------------------|-----|
| Temperature: | 25 °C | Relative Humidity: | 55% |
| Test Voltage: | AC 230V | | |
| Ant. Pol. | Horizontal | | |
| Test Mode: | TX B Mode 2412MHz | | |
| Remark: | No report for the emission which more than 10 dB below the prescribed limit. | | |

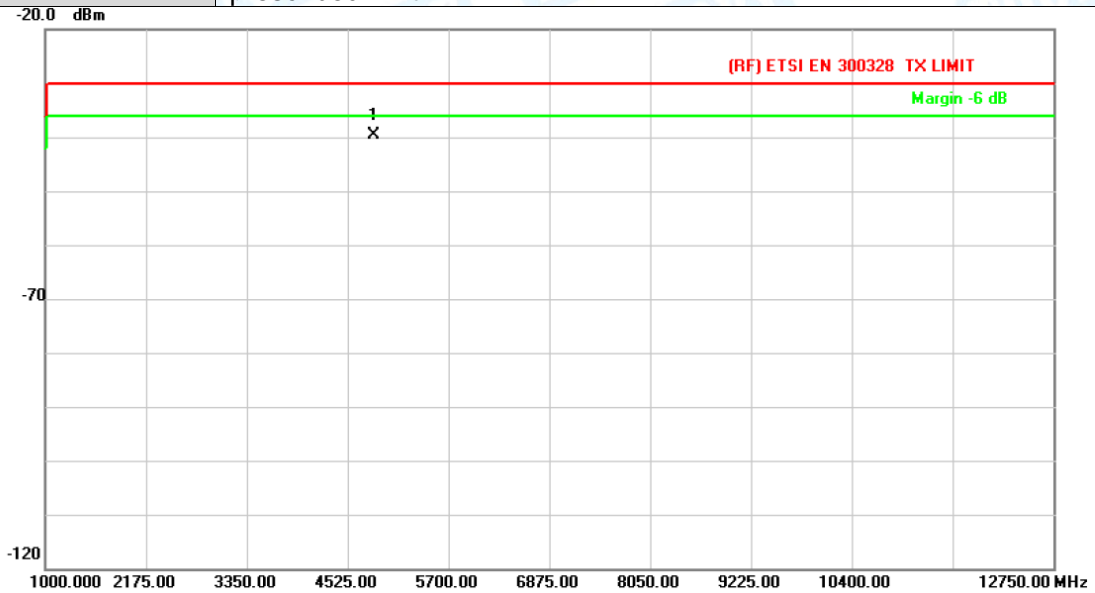

| No. | Mk. | Freq. | Reading Level | Correct Factor | Measurement | Limit | Over | Detector |
|-----|-----|----------|---------------|----------------|-------------|--------|-------|----------|
| | | MHz | dBm | dB | dBm | dBm | dB | |
| 1 | * | 4824.306 | -64.65 | 25.11 | -39.54 | -30.00 | -9.54 | peak |

- Remark:**
1. Corr. = Antenna Factor (dB/m) + Cable Loss (dB)
 2. Margin (dB) = Peak(dBm) - Limit (dBm)

| | | | |
|----------------------|--|---------------------------|-----|
| Temperature: | 25 °C | Relative Humidity: | 55% |
| Test Voltage: | AC 230V | | |
| Ant. Pol. | Vertical | | |
| Test Mode: | TX B Mode 2412MHz | | |
| Remark: | No report for the emission which more than 10 dB below the prescribed limit. | | |

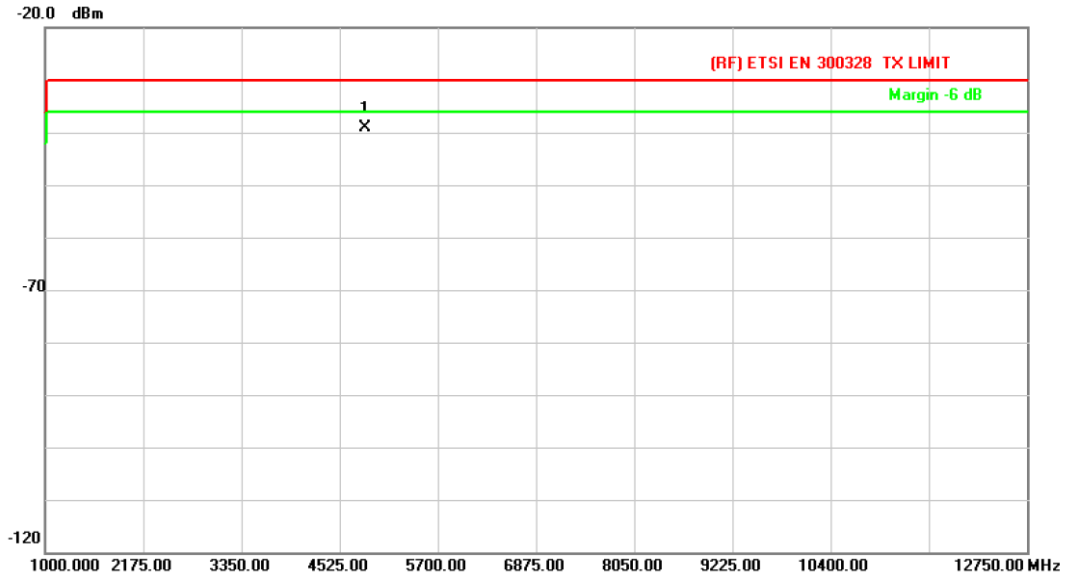

| No. | Mk. | Freq. MHz | Reading Level dBm | Correct Factor dB | Measure- ment dBm | Limit dBm | Over dB | Detector |
|-----|-----|--------------|-------------------------|-------------------------|-------------------------|--------------|------------|----------|
| 1 | * | 4823.872 | -66.38 | 27.16 | -39.22 | -30.00 | -9.22 | peak |

Remark:

1. Corr. = Antenna Factor (dB/m) + Cable Loss (dB)

2. Margin (dB) = Peak(dBm) - Limit (dBm)

| | | | |
|----------------------|--|---------------------------|-----|
| Temperature: | 25 °C | Relative Humidity: | 55% |
| Test Voltage: | AC 230V | | |
| Ant. Pol. | Horizontal | | |
| Test Mode: | TX B Mode 2472MHz | | |
| Remark: | No report for the emission which more than 10 dB below the prescribed limit. | | |

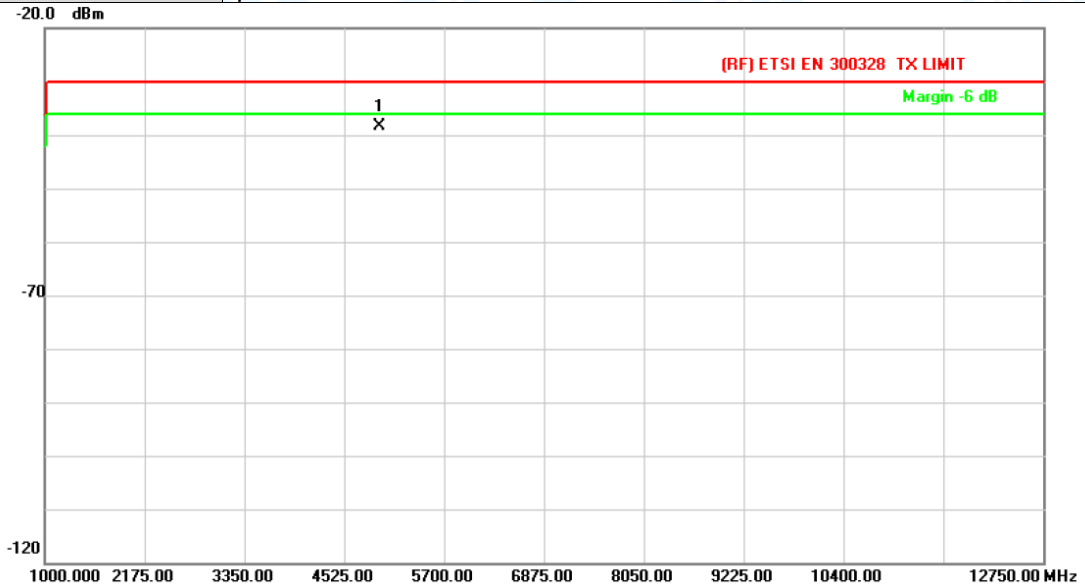

| No. | Mk. | Freq. | Reading Level | Correct Factor | Measurement | Limit | Over | Detector |
|-----|-----|----------|---------------|----------------|-------------|--------|-------|----------|
| | | MHz | dBm | dB | dBm | dBm | dB | |
| 1 | * | 4943.966 | -64.03 | 25.76 | -38.27 | -30.00 | -8.27 | peak |

Remark:

1. Corr. = Antenna Factor (dB/m) + Cable Loss (dB)
2. Margin (dB) = Peak(dBm) - Limit (dBm)

| | | | |
|----------------------|--|---------------------------|-----|
| Temperature: | 25 °C | Relative Humidity: | 55% |
| Test Voltage: | AC 230V | | |
| Ant. Pol. | Vertical | | |
| Test Mode: | TX B Mode 2472MHz | | |
| Remark: | No report for the emission which more than 10 dB below the prescribed limit. | | |

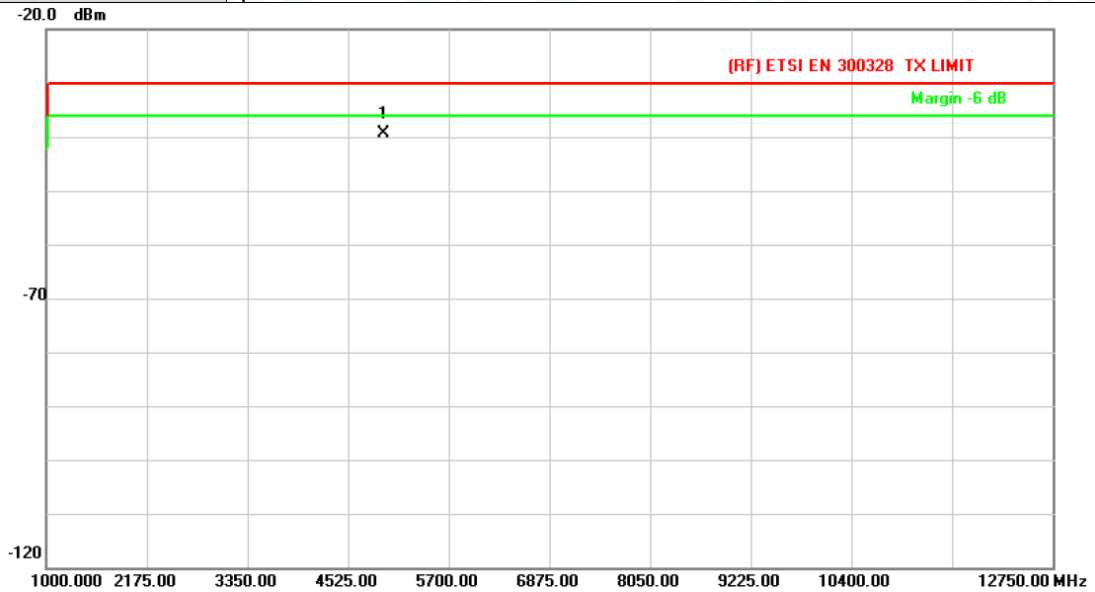

| No. | Mk. | Freq. MHz | Reading Level dBm | Correct Factor dB | Measure- ment dBm | Limit dBm | Over dB | Detector |
|-----|-----|--------------|-------------------------|-------------------------|-------------------------|--------------|------------|----------|
| 1 | * | 4943.578 | -67.21 | 27.93 | -39.28 | -30.00 | -9.28 | peak |

Remark:

1. Corr. = Antenna Factor (dB/m) + Cable Loss (dB)
2. Margin (dB) = Peak(dBm) - Limit (dBm)

| | | | |
|----------------------|--|---------------------------|-----|
| Temperature: | 25 °C | Relative Humidity: | 55% |
| Test Voltage: | AC 230V | | |
| Ant. Pol. | Horizontal | | |
| Test Mode: | TX G Mode 2412MHz | | |
| Remark: | No report for the emission which more than 10 dB below the prescribed limit. | | |

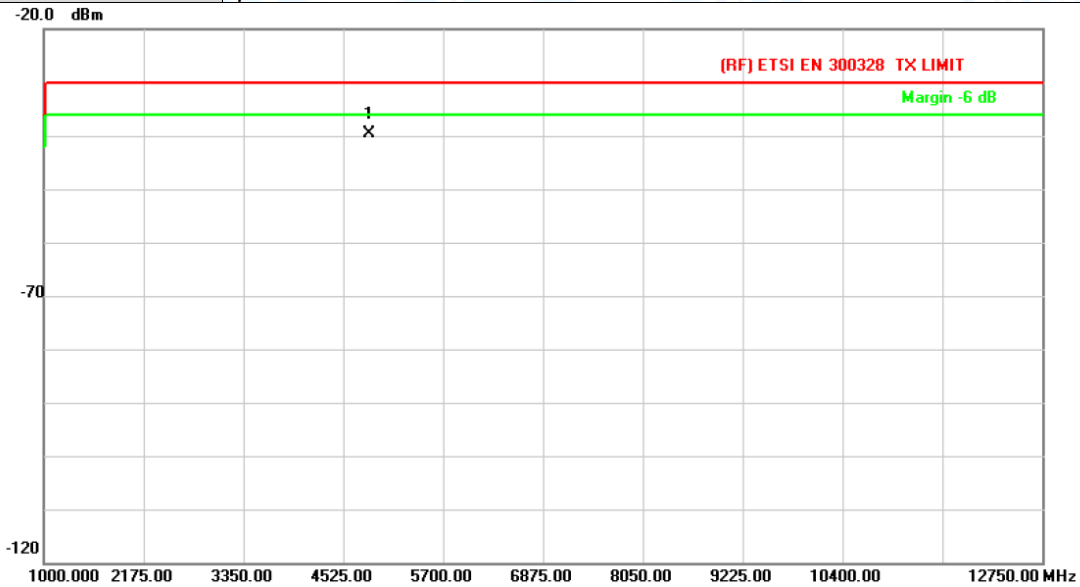

| No. | Mk. | Freq. MHz | Reading Level dBm | Correct Factor dB | Measure- ment dBm | Limit dBm | Over dB | Detector |
|-----|-----|--------------|-------------------------|-------------------------|-------------------------|--------------|------------|----------|
| 1 | * | 4823.990 | -64.76 | 25.11 | -39.65 | -30.00 | -9.65 | peak |

Remark:

1. Corr. = Antenna Factor (dB/m) + Cable Loss (dB)
2. Margin (dB) = Peak(dBm) - Limit (dBm)

| | | | |
|----------------------|--|---------------------------|-----|
| Temperature: | 25 °C | Relative Humidity: | 55% |
| Test Voltage: | AC 230V | | |
| Ant. Pol. | Vertical | | |
| Test Mode: | TX G Mode 2412MHz | | |
| Remark: | No report for the emission which more than 10 dB below the prescribed limit. | | |

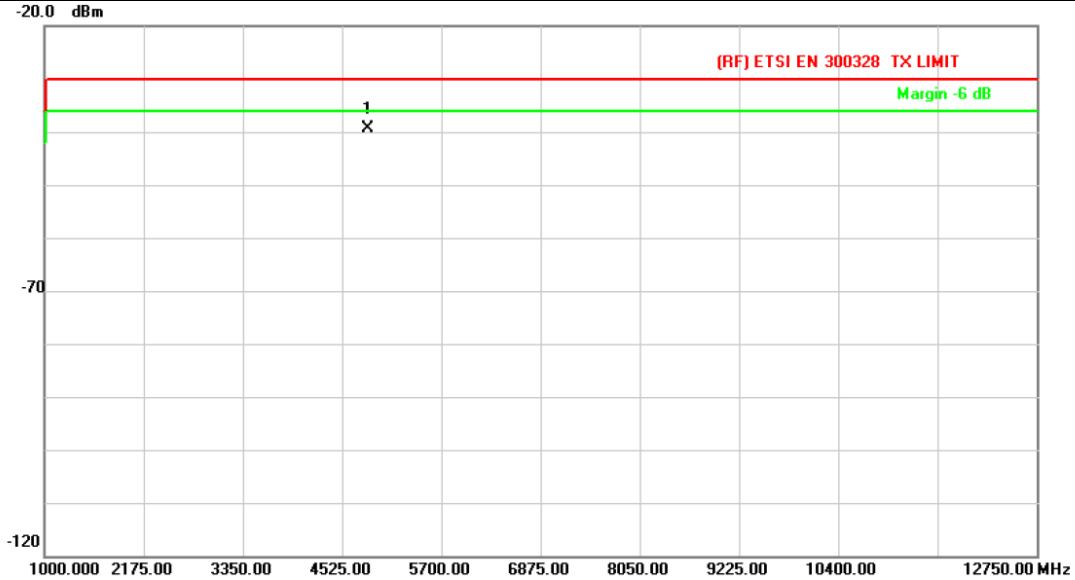

| No. | Mk. | Freq. MHz | Reading Level dBm | Correct Factor dB | Measure- ment dBm | Limit dBm | Over dB | Detector |
|-----|-----|--------------|-------------------------|-------------------------|-------------------------|--------------|------------|----------|
| 1 | * | 4823.652 | -66.63 | 27.16 | -39.47 | -30.00 | -9.47 | peak |

Remark:

1. Corr. = Antenna Factor (dB/m) + Cable Loss (dB)
2. Margin (dB) = Peak(dBm) - Limit (dBm)

| | | | |
|---------------|--|--------------------|-----|
| Temperature: | 25 °C | Relative Humidity: | 55% |
| Test Voltage: | AC 230V | | |
| Ant. Pol. | Horizontal | | |
| Test Mode: | TX G Mode 2472MHz | | |
| Remark: | No report for the emission which more than 10 dB below the prescribed limit. | | |

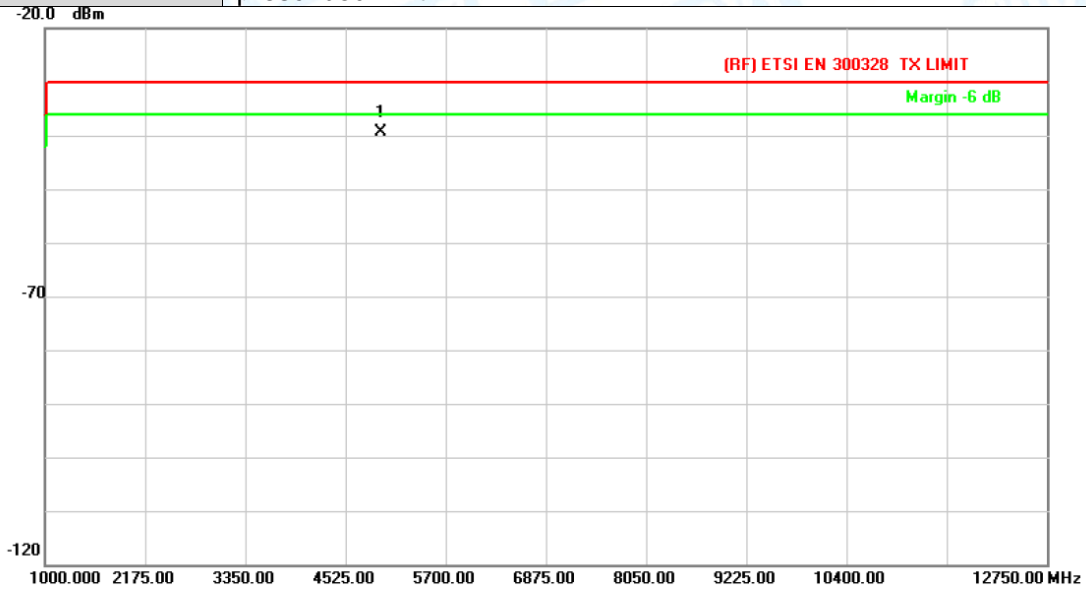

| No. | Mk. | Freq. | Reading Level | Correct Factor | Measurement | Limit | Over | Detector |
|-----|-----|----------|---------------|----------------|-------------|--------|-------|----------|
| | | MHz | dBm | dB | dBm | dBm | dB | |
| 1 | * | 4944.452 | -65.11 | 25.76 | -39.35 | -30.00 | -9.35 | peak |

- Remark:
1. Corr. = Antenna Factor (dB/m) + Cable Loss (dB)
 2. Margin (dB) = Peak(dBm) - Limit (dBm)

| | | | |
|----------------------|--|---------------------------|-----|
| Temperature: | 25 °C | Relative Humidity: | 55% |
| Test Voltage: | AC 230V | | |
| Ant. Pol. | Vertical | | |
| Test Mode: | TX G Mode 2472MHz | | |
| Remark: | No report for the emission which more than 10 dB below the prescribed limit. | | |

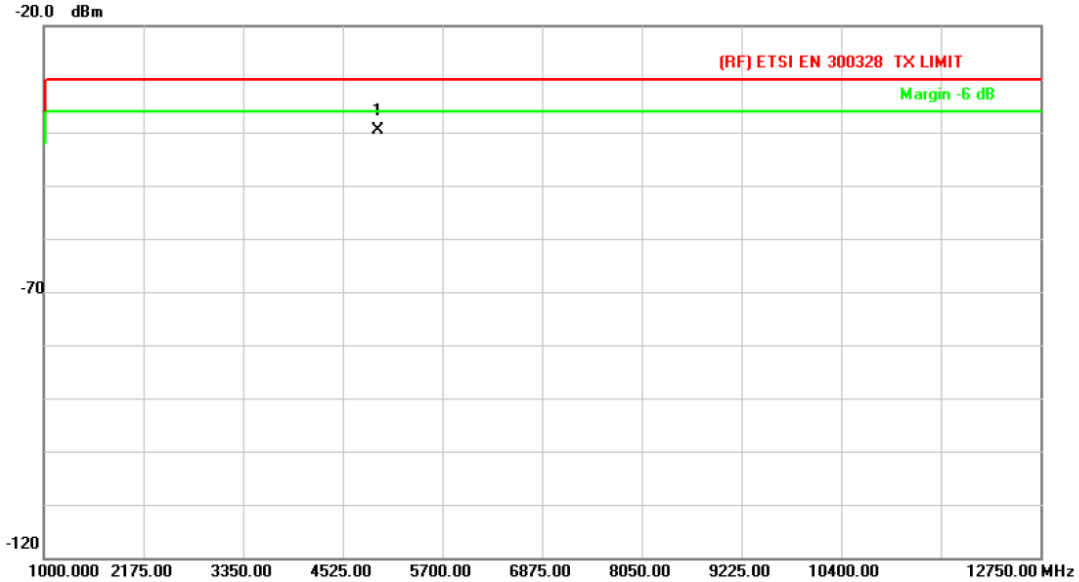

| No. | Mk. | Freq. MHz | Reading Level dBm | Correct Factor dB | Measure- ment dBm | Limit dBm | Over dB | Detector |
|-----|-----|--------------|-------------------------|-------------------------|-------------------------|--------------|------------|----------|
| 1 | * | 4943.848 | -67.66 | 27.93 | -39.73 | -30.00 | -9.73 | peak |

Remark:

1. Corr. = Antenna Factor (dB/m) + Cable Loss (dB)

2. Margin (dB) = Peak(dBm) - Limit (dBm)

| | | | |
|----------------------|--|---------------------------|-----|
| Temperature: | 25 °C | Relative Humidity: | 55% |
| Test Voltage: | AC 230V | | |
| Ant. Pol. | Horizontal | | |
| Test Mode: | TX N20 Mode 2412MHz | | |
| Remark: | No report for the emission which more than 10 dB below the prescribed limit. | | |

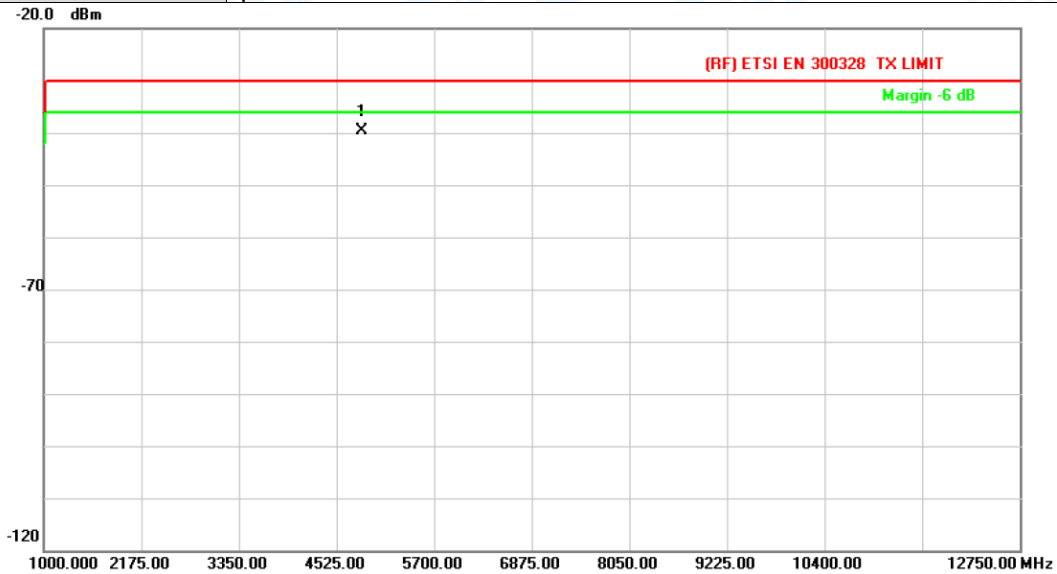

| No. | Mk. | Freq. MHz | Reading Level dBm | Correct Factor dB | Measure- ment dBm | Limit dBm | Over dB | Detector |
|-----|-----|--------------|-------------------------|-------------------------|-------------------------|--------------|------------|----------|
| 1 | * | 4824.312 | -64.61 | 25.11 | -39.50 | -30.00 | -9.50 | peak |

Remark:

1. Corr. = Antenna Factor (dB/m) + Cable Loss (dB)
2. Margin (dB) = Peak(dBm) - Limit (dBm)

| | | | |
|----------------------|--|---------------------------|-----|
| Temperature: | 25 °C | Relative Humidity: | 55% |
| Test Voltage: | AC 230V | | |
| Ant. Pol. | Vertical | | |
| Test Mode: | TX N20 Mode 2412MHz | | |
| Remark: | No report for the emission which more than 10 dB below the prescribed limit. | | |

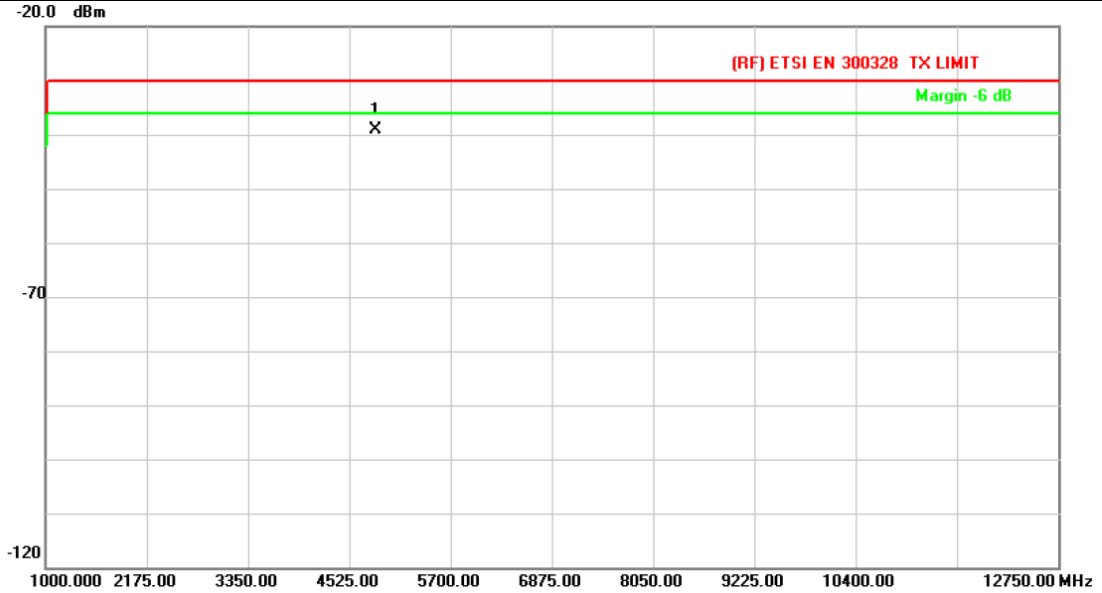

| No. | Mk. | Freq. MHz | Reading Level dBm | Correct Factor dB | Measure- ment dBm | Limit dBm | Over dB | Detector |
|-----|-----|--------------|-------------------------|-------------------------|-------------------------|--------------|------------|----------|
| 1 | * | 4824.018 | -66.37 | 27.16 | -39.21 | -30.00 | -9.21 | peak |

Remark:

1. Corr. = Antenna Factor (dB/m) + Cable Loss (dB)

2. Margin (dB) = Peak(dBm) - Limit (dBm)

| | | | |
|----------------------|--|---------------------------|-----|
| Temperature: | 25 °C | Relative Humidity: | 55% |
| Test Voltage: | AC 230V | | |
| Ant. Pol. | Horizontal | | |
| Test Mode: | TX N20 Mode 2472MHz | | |
| Remark: | No report for the emission which more than 10 dB below the prescribed limit. | | |

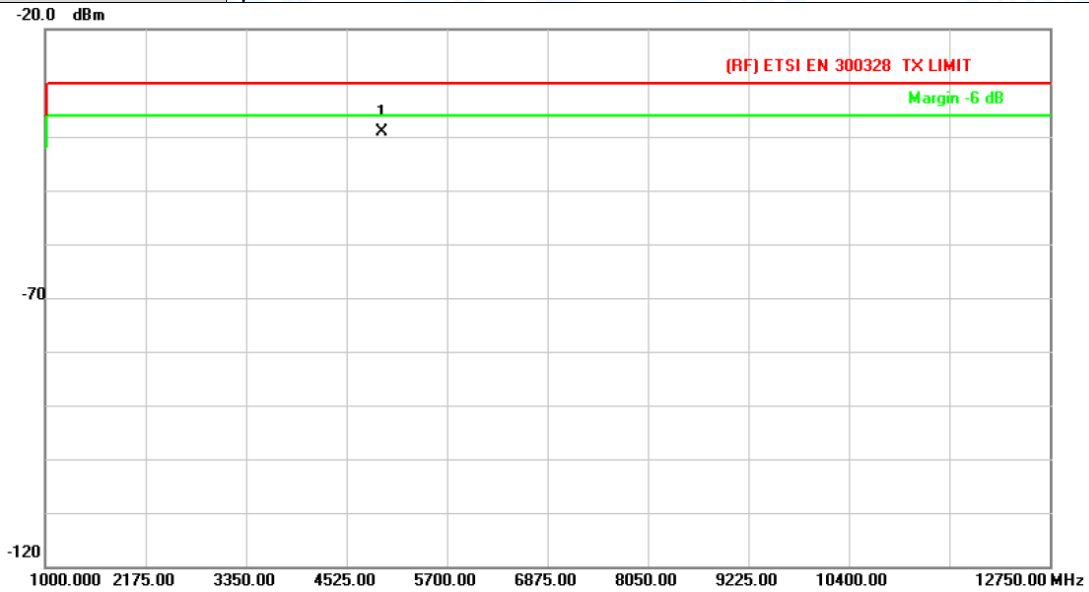

| No. | Mk. | Freq. | Reading Level | Correct Factor | Measurement | Limit | Over | Detector |
|-----|-----|----------|---------------|----------------|-------------|--------|-------|----------|
| | | MHz | dBm | dB | dBm | dBm | dB | |
| 1 | * | 4944.012 | -64.77 | 25.76 | -39.01 | -30.00 | -9.01 | peak |

Remark:

1. Corr. = Antenna Factor (dB/m) + Cable Loss (dB)
2. Margin (dB) = Peak(dBm) - Limit (dBm)

| | | | |
|----------------------|--|---------------------------|-----|
| Temperature: | 25 °C | Relative Humidity: | 55% |
| Test Voltage: | AC 230V | | |
| Ant. Pol. | Vertical | | |
| Test Mode: | TX N20 Mode 2472MHz | | |
| Remark: | No report for the emission which more than 10 dB below the prescribed limit. | | |

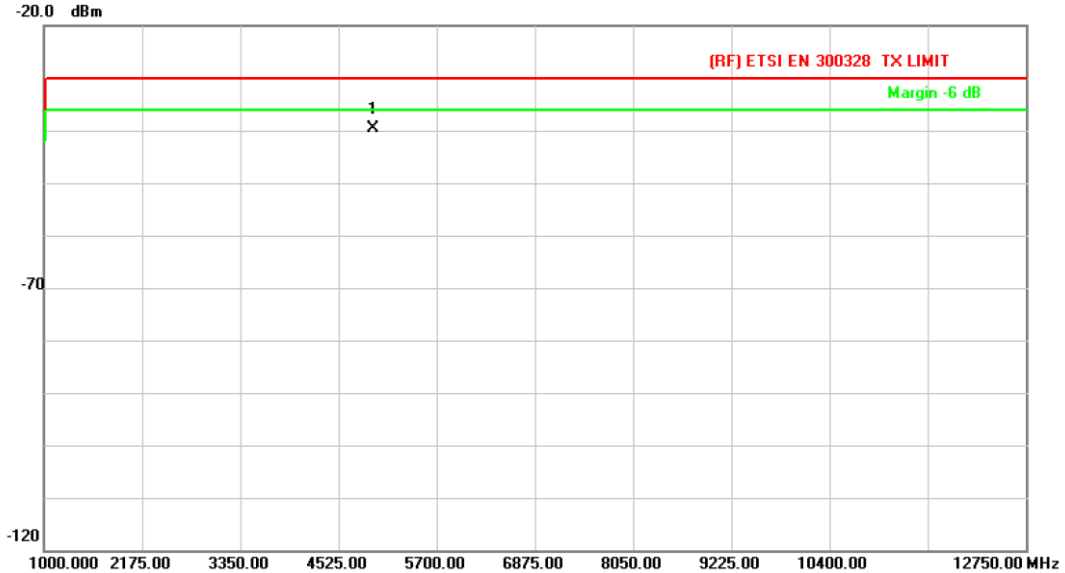

| No. | Mk. | Freq. MHz | Reading Level dBm | Correct Factor dB | Measure- ment dBm | Limit dBm | Over dB | Detector |
|-----|-----|--------------|-------------------------|-------------------------|-------------------------|--------------|------------|----------|
| 1 | * | 4944.338 | -67.64 | 27.93 | -39.71 | -30.00 | -9.71 | peak |

Remark:

1. Corr. = Antenna Factor (dB/m) + Cable Loss (dB)
2. Margin (dB) = Peak(dBm) - Limit (dBm)

Attachment G-- Receiver spurious emissions Test Data

(1) Below 1 G

| | | | |
|---------------|---------------------------------------|--------------------|-----|
| Temperature: | 25 °C | Relative Humidity: | 55% |
| Test Voltage: | AC 230V | | |
| Ant. Pol. | Horizontal | | |
| Test Mode: | RX B Mode 2412MHz | | |
| Remark: | Only showed the worst mode test data. | | |

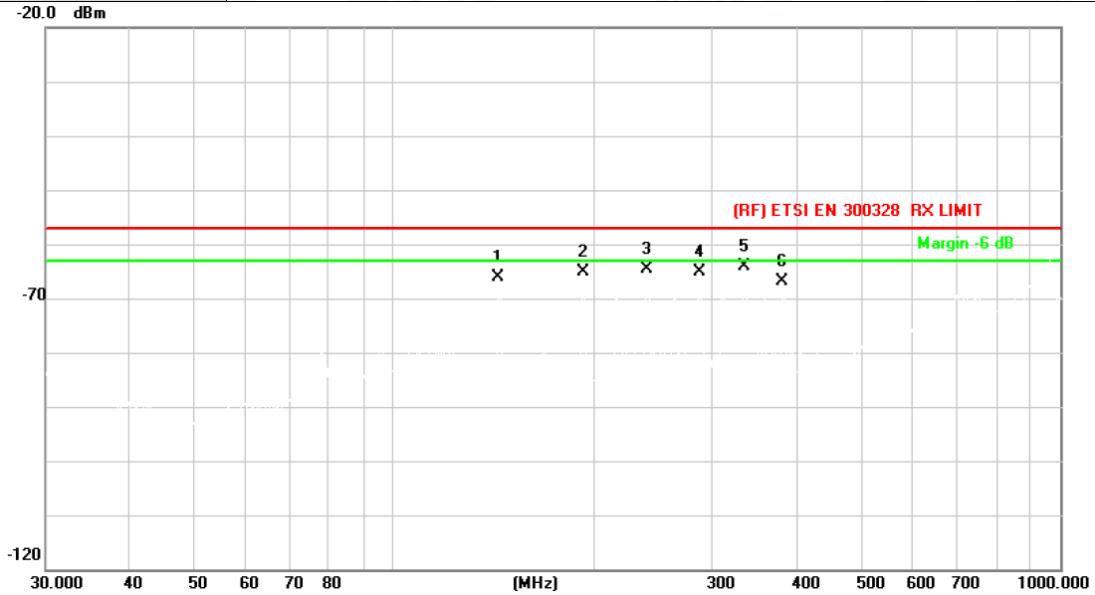

| No. | Mk. | Freq. MHz | Reading Level dBm | Correct Factor dB | Measure- ment dBm | Limit dBm | Over dB | Detector |
|-----|-----|--------------|-------------------------|-------------------------|-------------------------|--------------|------------|----------|
| 1 | | 143.3261 | -55.95 | -10.23 | -66.18 | -57.00 | -9.18 | peak |
| 2 | | 192.4186 | -57.77 | -7.34 | -65.11 | -57.00 | -8.11 | peak |
| 3 | | 239.1473 | -66.98 | 2.45 | -64.53 | -57.00 | -7.53 | peak |
| 4 | | 286.9823 | -58.96 | -6.07 | -65.03 | -57.00 | -8.03 | peak |
| 5 | * | 334.8589 | -57.05 | -7.05 | -64.10 | -57.00 | -7.10 | peak |
| 6 | | 382.5879 | -63.81 | -2.96 | -66.77 | -57.00 | -9.77 | peak |

Remark:

1. Corr. = Antenna Factor (dB/m) + Cable Loss (dB)

2. Margin (dB) = Peak(dBm) - Limit (dBm)

| | | | |
|----------------------|---------------------------------------|---------------------------|-----|
| Temperature: | 25 °C | Relative Humidity: | 55% |
| Test Voltage: | AC 230V | | |
| Ant. Pol. | Vertical | | |
| Test Mode: | RX B Mode 2412MHz | | |
| Remark: | Only showed the worst mode test data. | | |

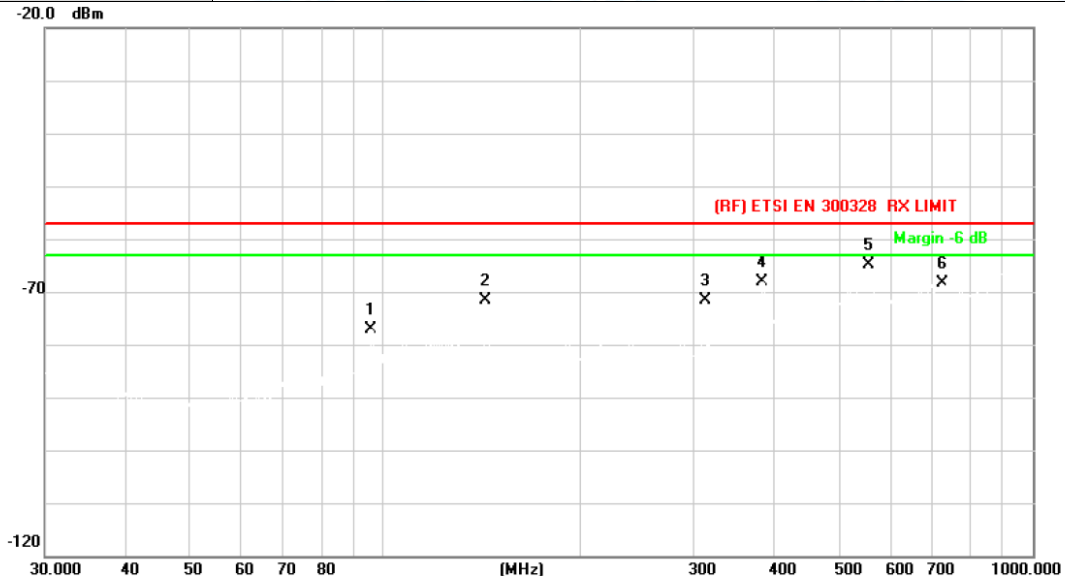

| No. | Mk. | Freq. MHz | Reading Level dBm | Correct Factor dB | Measurement dBm | Limit dBm | Over dB | Detector |
|-----|-----|--------------|-------------------------|-------------------------|--------------------|--------------|------------|----------|
| 1 | | 95.4270 | -68.11 | -8.94 | -77.05 | -57.00 | -20.05 | peak |
| 2 | | 143.3261 | -63.74 | -7.77 | -71.51 | -57.00 | -14.51 | peak |
| 3 | | 312.1794 | -65.92 | -5.70 | -71.62 | -57.00 | -14.62 | peak |
| 4 | | 382.5879 | -66.94 | -1.30 | -68.24 | -57.00 | -11.24 | peak |
| 5 | * | 558.7302 | -68.62 | 3.83 | -64.79 | -57.00 | -7.79 | peak |
| 6 | | 724.2611 | -74.07 | 5.67 | -68.40 | -57.00 | -11.40 | peak |

Remark:

1. Corr. = Antenna Factor (dB/m) + Cable Loss (dB)

2. Margin (dB) = Peak(dBm) - Limit (dBm)

(2) Above 1 GHz

| | | | |
|----------------------|--|---------------------------|-----|
| Temperature: | 25 °C | Relative Humidity: | 55% |
| Test Voltage: | AC 230V | | |
| Ant. Pol. | Horizontal | | |
| Test Mode: | RX B Mode 2412MHz | | |
| Remark: | No report for the emission which more than 10 dB below the prescribed limit. | | |

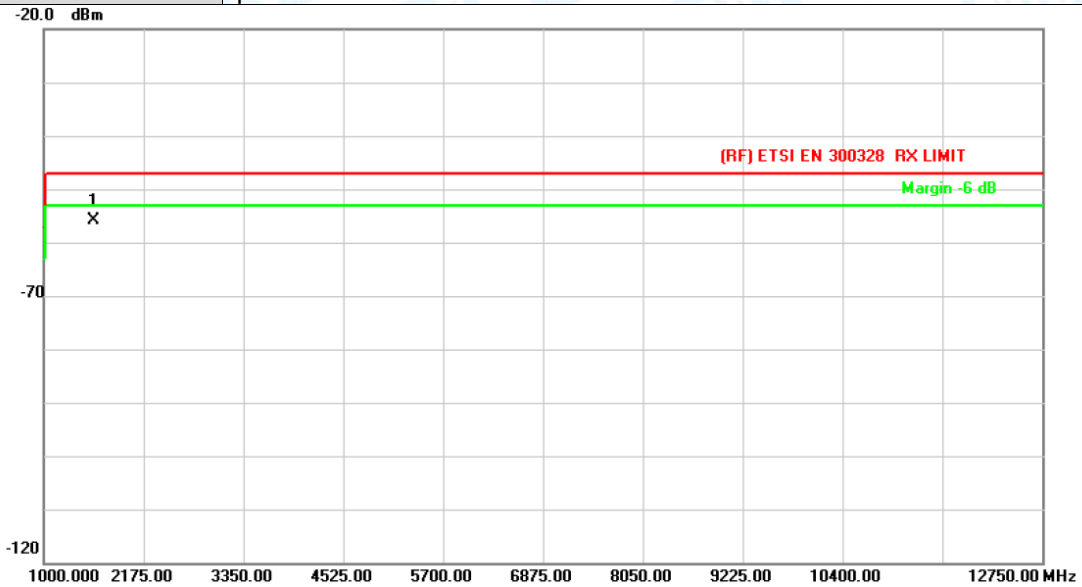

| No. | Mk. | Freq. | Reading Level | Correct Factor | Measurement | Limit | Over | Detector |
|-----|-----|----------|---------------|----------------|-------------|--------|-------|----------|
| | | MHz | dBm | dB | dBm | dBm | dB | |
| 1 | * | 1595.007 | -63.81 | 7.95 | -55.86 | -47.00 | -8.86 | peak |

Remark:

1. Corr. = Antenna Factor (dB/m) + Cable Loss (dB)

2. Margin (dB) = Peak(dBm) - Limit (dBm)

| | | | |
|----------------------|--|---------------------------|-----|
| Temperature: | 25 °C | Relative Humidity: | 55% |
| Test Voltage: | AC 230V | | |
| Ant. Pol. | Vertical | | |
| Test Mode: | RX B Mode 2412MHz | | |
| Remark: | No report for the emission which more than 10 dB below the prescribed limit. | | |

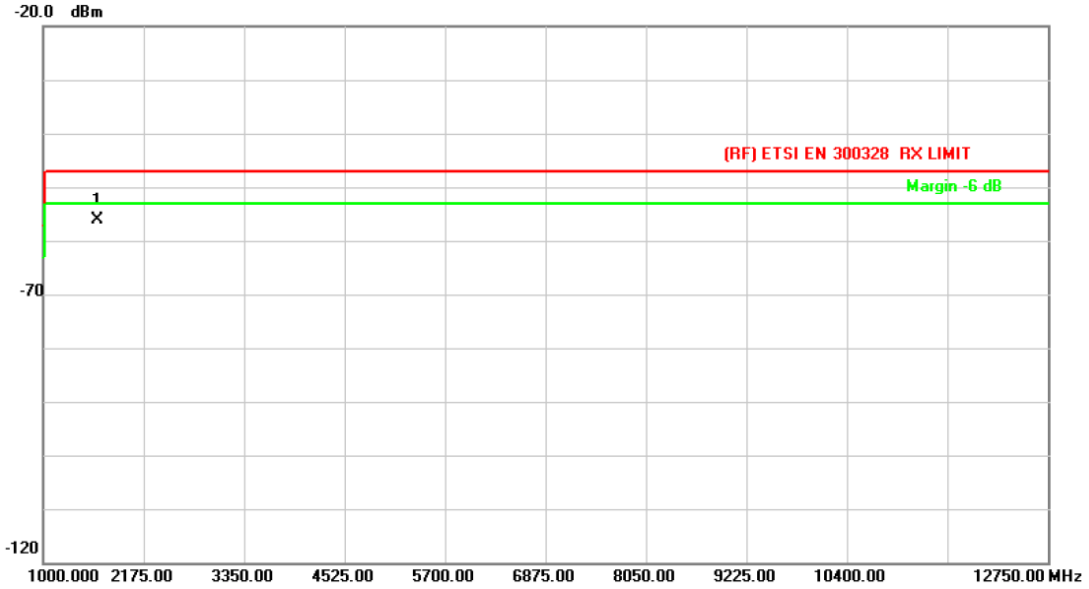

| No. | Mk. | Freq. | Reading Level | Correct Factor | Measurement | Limit | Over | Detector |
|-----|-----|----------|---------------|----------------|-------------|--------|-------|----------|
| | | MHz | dBm | dB | dBm | dBm | dB | |
| 1 | * | 1630.633 | -64.70 | 8.49 | -56.21 | -47.00 | -9.21 | peak |

Remark:

1. Corr. = Antenna Factor (dB/m) + Cable Loss (dB)
2. Margin (dB) = Peak(dBm) - Limit (dBm)

| | | | |
|----------------------|--|---------------------------|-----|
| Temperature: | 25 °C | Relative Humidity: | 55% |
| Test Voltage: | AC 230V | | |
| Ant. Pol. | Horizontal | | |
| Test Mode: | RX B Mode 2472MHz | | |
| Remark: | No report for the emission which more than 10 dB below the prescribed limit. | | |

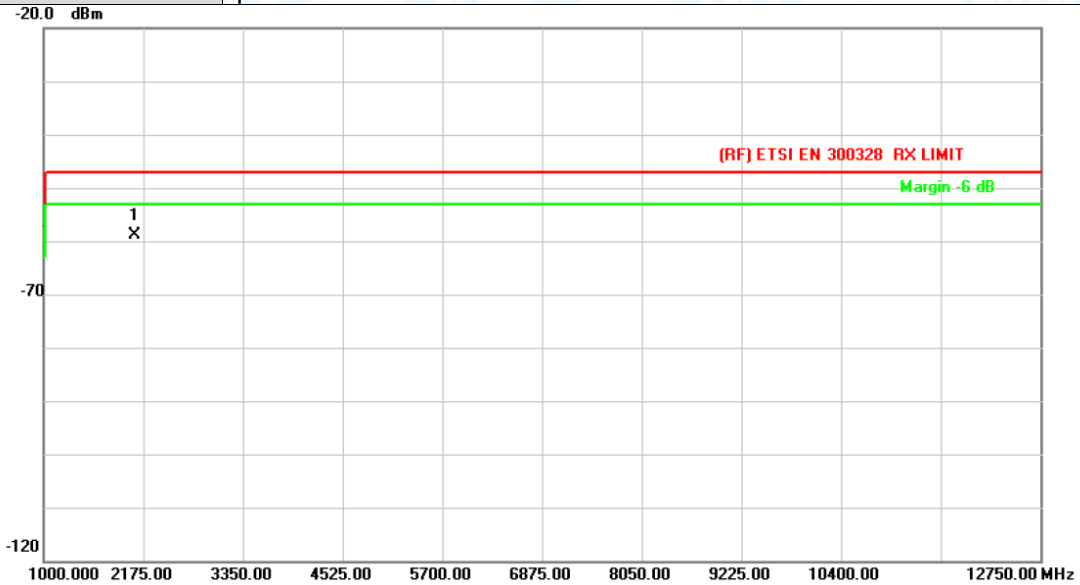

| No. | Mk. | Freq. | Reading Level | Correct Factor | Measurement | Limit | Over | Detector |
|-----|-----|----------|---------------|----------------|-------------|--------|--------|----------|
| | | MHz | dBm | dB | dBm | dBm | dB | |
| 1 | * | 2079.144 | -67.48 | 8.56 | -58.92 | -47.00 | -11.92 | peak |

Remark:

1. Corr. = Antenna Factor (dB/m) + Cable Loss (dB)
2. Margin (dB) = Peak(dBm) - Limit (dBm)

| | | | |
|----------------------|--|---------------------------|-----|
| Temperature: | 25 °C | Relative Humidity: | 55% |
| Test Voltage: | AC 230V | | |
| Ant. Pol. | Vertical | | |
| Test Mode: | RX B Mode 2472MHz | | |
| Remark: | No report for the emission which more than 10 dB below the prescribed limit. | | |

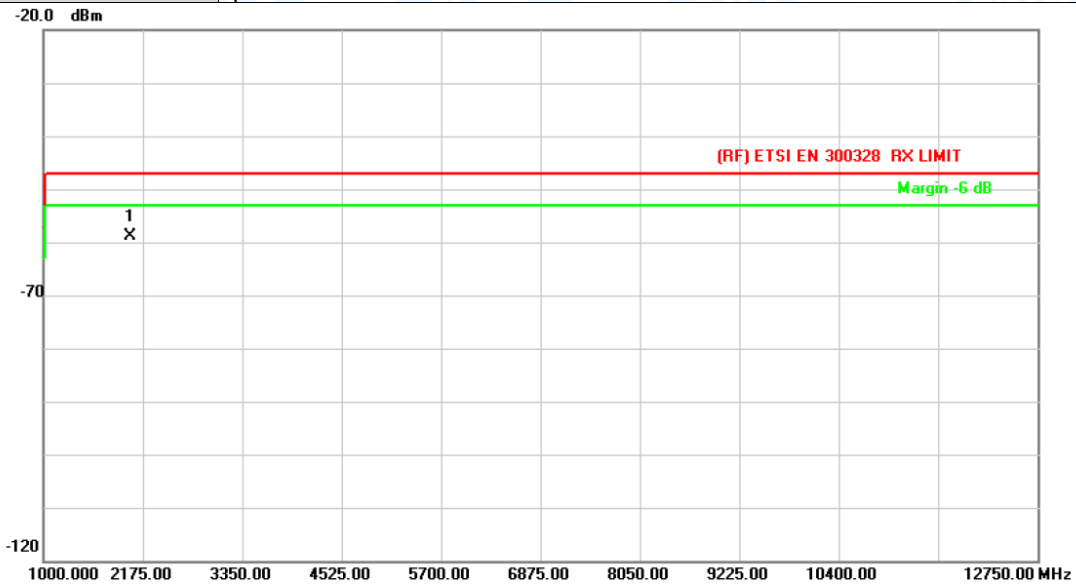

| No. | Mk. | Freq. MHz | Reading Level dBm | Correct Factor dB | Measure- ment dBm | Limit dBm | Over dB | Detector |
|-----|-----|--------------|-------------------------|-------------------------|-------------------------|--------------|------------|----------|
| 1 | * | 2033.719 | -67.84 | 8.92 | -58.92 | -47.00 | -11.92 | peak |

Remark:

1. Corr. = Antenna Factor (dB/m) + Cable Loss (dB)

2. Margin (dB) = Peak(dBm) - Limit (dBm)

| | | | |
|----------------------|--|---------------------------|-----|
| Temperature: | 25 °C | Relative Humidity: | 55% |
| Test Voltage: | AC 230V | | |
| Ant. Pol. | Horizontal | | |
| Test Mode: | RX G Mode 2412MHz | | |
| Remark: | No report for the emission which more than 10 dB below the prescribed limit. | | |

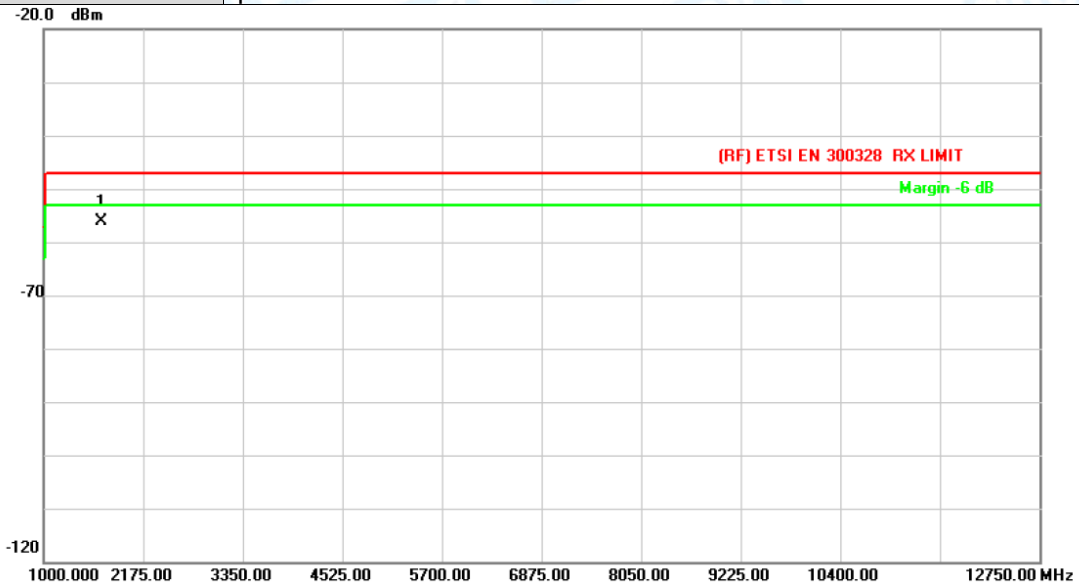

| No. | Mk. | Freq. MHz | Reading Level dBm | Correct Factor dB | Measure- ment dBm | Limit dBm | Over dB | Detector |
|-----|-----|--------------|-------------------------|-------------------------|-------------------------|--------------|------------|----------|
| 1 | * | 1677.609 | -65.13 | 8.98 | -56.15 | -47.00 | -9.15 | peak |

Remark:

1. Corr. = Antenna Factor (dB/m) + Cable Loss (dB)
2. Margin (dB) = Peak(dBm) - Limit (dBm)

| | | | |
|----------------------|--|---------------------------|-----|
| Temperature: | 25 °C | Relative Humidity: | 55% |
| Test Voltage: | AC 230V | | |
| Ant. Pol. | Vertical | | |
| Test Mode: | RX G Mode 2412MHz | | |
| Remark: | No report for the emission which more than 10 dB below the prescribed limit. | | |

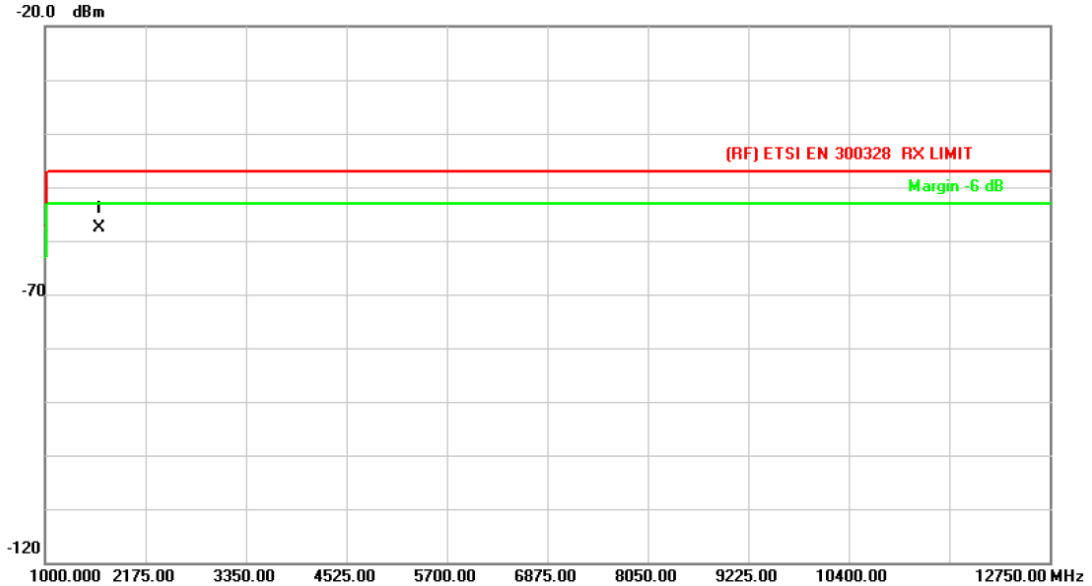

| No. | Mk. | Freq. | Reading Level | Correct Factor | Measurement | Limit | Over | Detector |
|-----|-----|----------|---------------|----------------|-------------|--------|--------|----------|
| | | MHz | dBm | dB | dBm | dBm | dB | |
| 1 | * | 1635.787 | -66.03 | 8.37 | -57.66 | -47.00 | -10.66 | peak |

Remark:

1. Corr. = Antenna Factor (dB/m) + Cable Loss (dB)

2. Margin (dB) = Peak(dBm) - Limit (dBm)

| | | | |
|----------------------|--|---------------------------|-----|
| Temperature: | 25 °C | Relative Humidity: | 55% |
| Test Voltage: | AC 230V | | |
| Ant. Pol. | Horizontal | | |
| Test Mode: | RX G Mode 2472MHz | | |
| Remark: | No report for the emission which more than 10 dB below the prescribed limit. | | |

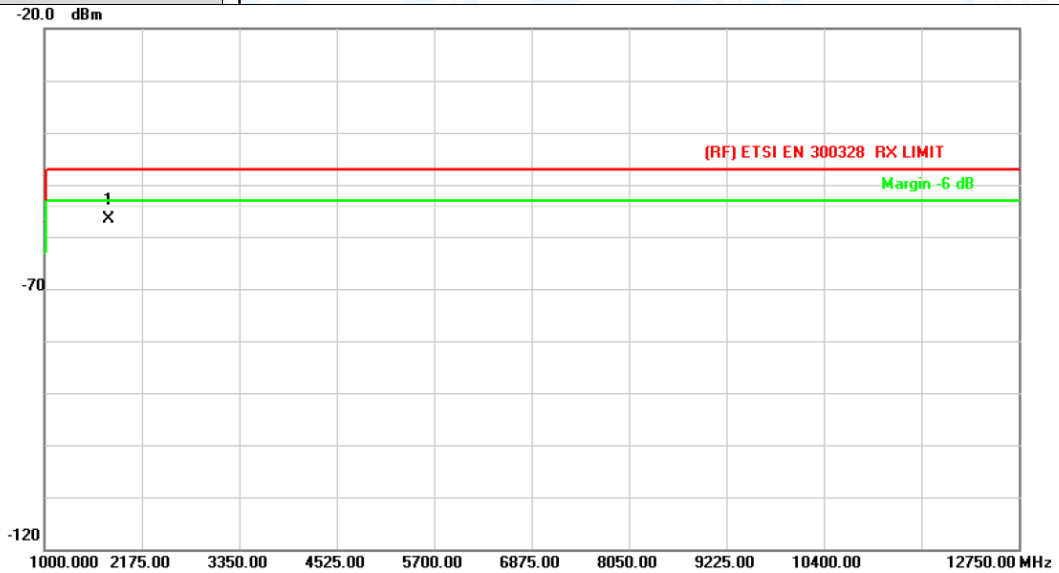

| No. | Mk. | Freq. MHz | Reading Level dBm | Correct Factor dB | Measure- ment dBm | Limit dBm | Over dB | Detector |
|-----|-----|--------------|-------------------------|-------------------------|-------------------------|--------------|------------|----------|
| 1 | * | 1775.659 | -66.36 | 9.78 | -56.58 | -47.00 | -9.58 | peak |

Remark:

1. Corr. = Antenna Factor (dB/m) + Cable Loss (dB)

2. Margin (dB) = Peak(dBm) - Limit (dBm)

| | | | |
|----------------------|--|---------------------------|-----|
| Temperature: | 25 °C | Relative Humidity: | 55% |
| Test Voltage: | AC 230V | | |
| Ant. Pol. | Vertical | | |
| Test Mode: | RX G Mode 2472MHz | | |
| Remark: | No report for the emission which more than 10 dB below the prescribed limit. | | |

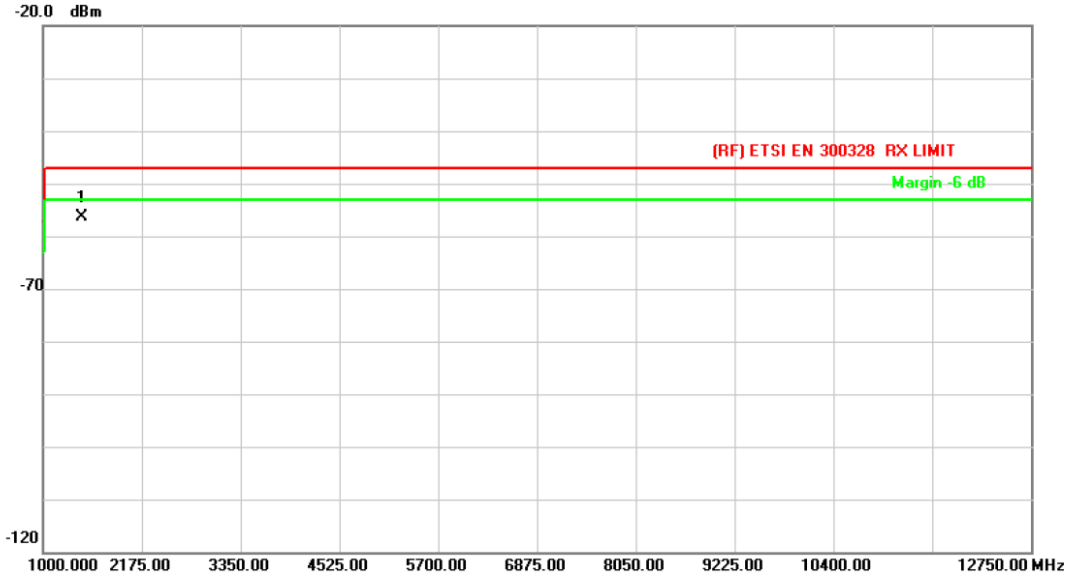

| No. | Mk. | Freq. MHz | Reading Level dBm | Correct Factor dB | Measure- ment dBm | Limit dBm | Over dB | Detector |
|-----|-----|--------------|-------------------------|-------------------------|-------------------------|--------------|------------|----------|
| 1 | * | 1460.121 | -63.94 | 7.59 | -56.35 | -47.00 | -9.35 | peak |

Remark:

1. Corr. = Antenna Factor (dB/m) + Cable Loss (dB)
2. Margin (dB) = Peak(dBm) - Limit (dBm)

| | | | |
|----------------------|--|---------------------------|-----|
| Temperature: | 25 °C | Relative Humidity: | 55% |
| Test Voltage: | AC 230V | | |
| Ant. Pol. | Horizontal | | |
| Test Mode: | RX N20 Mode 2412MHz | | |
| Remark: | No report for the emission which more than 10 dB below the prescribed limit. | | |

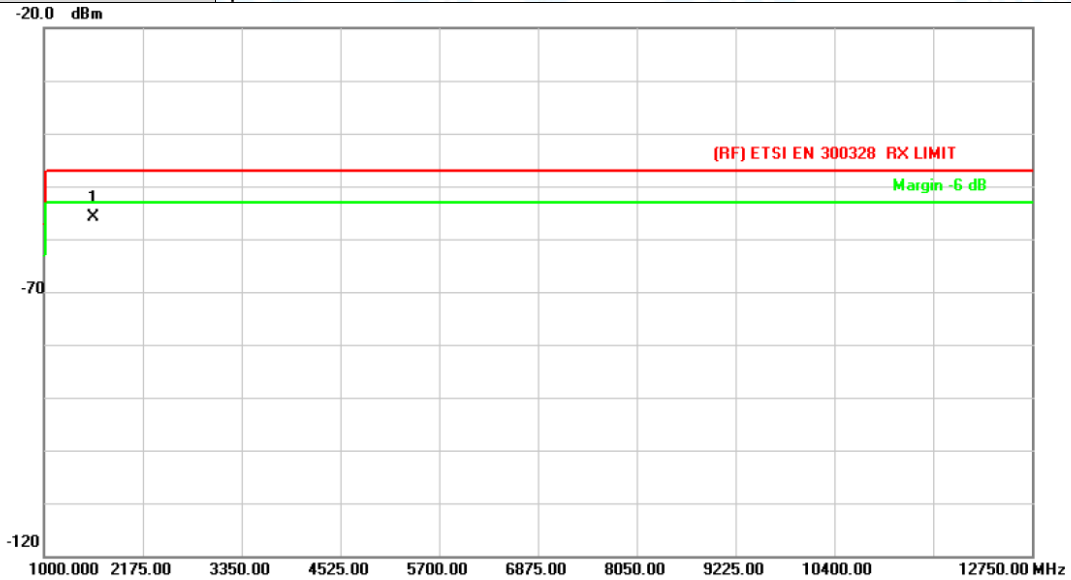

| No. | Mk. | Freq. MHz | Reading Level dBm | Correct Factor dB | Measure- ment dBm | Limit dBm | Over dB | Detector |
|-----|-----|--------------|-------------------------|-------------------------|-------------------------|--------------|------------|----------|
| 1 | * | 1595.007 | -63.81 | 7.95 | -55.86 | -47.00 | -8.86 | peak |

Remark:

1. Corr. = Antenna Factor (dB/m) + Cable Loss (dB)
2. Margin (dB) = Peak(dBm) - Limit (dBm)

| | | | |
|----------------------|--|---------------------------|-----|
| Temperature: | 25 °C | Relative Humidity: | 55% |
| Test Voltage: | AC 230V | | |
| Ant. Pol. | Vertical | | |
| Test Mode: | RX N20 Mode 2412MHz | | |
| Remark: | No report for the emission which more than 10 dB below the prescribed limit. | | |

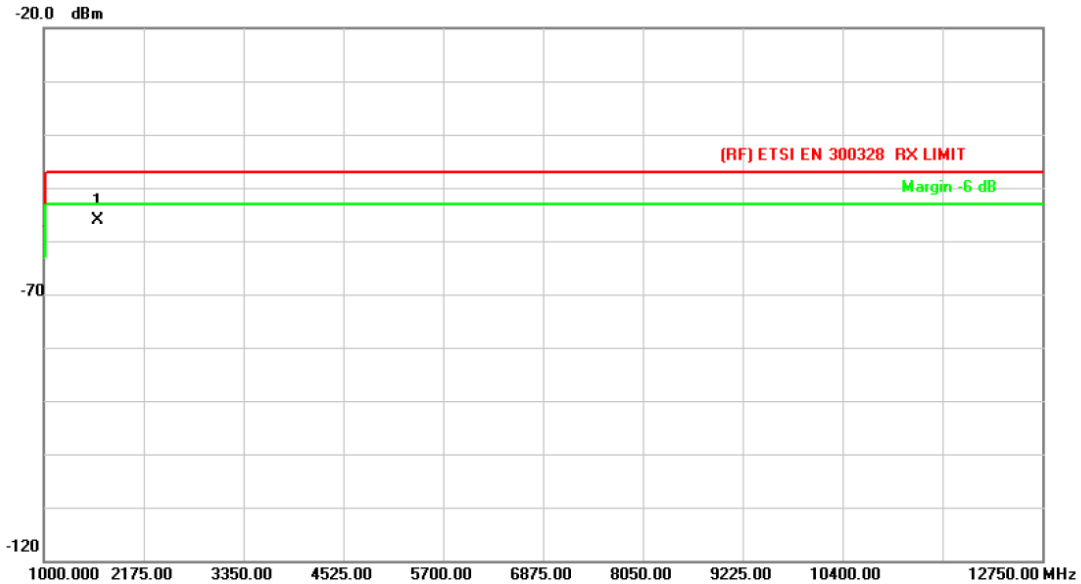

| No. | Mk. | Freq. MHz | Reading Level dBm | Correct Factor dB | Measure- ment dBm | Limit dBm | Over dB | Detector |
|-----|-----|--------------|-------------------------|-------------------------|-------------------------|--------------|------------|----------|
| 1 | * | 1630.633 | -64.70 | 8.49 | -56.21 | -47.00 | -9.21 | peak |

Remark:

1. Corr. = Antenna Factor (dB/m) + Cable Loss (dB)
2. Margin (dB) = Peak(dBm) - Limit (dBm)

| | | | |
|----------------------|--|---------------------------|-----|
| Temperature: | 25 °C | Relative Humidity: | 55% |
| Test Voltage: | AC 230V | | |
| Ant. Pol. | Horizontal | | |
| Test Mode: | RX N20 Mode 2472MHz | | |
| Remark: | No report for the emission which more than 10 dB below the prescribed limit. | | |

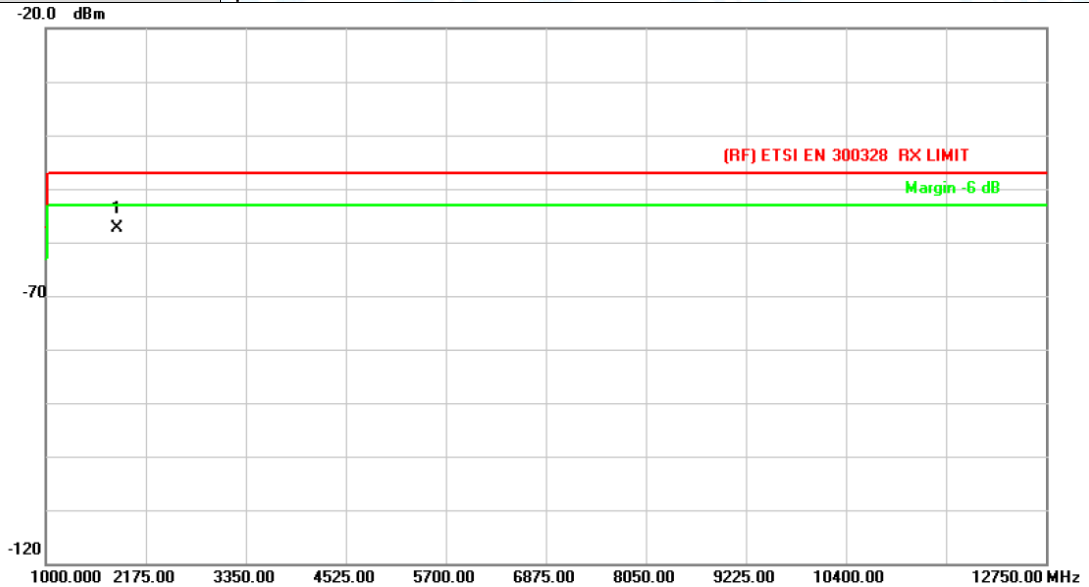

| No. | Mk. | Freq. MHz | Reading Level dBm | Correct Factor dB | Measure- ment dBm | Limit dBm | Over dB | Detector |
|-----|-----|--------------|-------------------------|-------------------------|-------------------------|--------------|------------|----------|
| 1 | * | 1832.587 | -65.18 | 7.76 | -57.42 | -47.00 | -10.42 | peak |

Remark:

1. Corr. = Antenna Factor (dB/m) + Cable Loss (dB)
2. Margin (dB) = Peak(dBm) - Limit (dBm)

| | | | |
|----------------------|--|---------------------------|-----|
| Temperature: | 25 °C | Relative Humidity: | 55% |
| Test Voltage: | AC 230V | | |
| Ant. Pol. | Vertical | | |
| Test Mode: | RX N20 Mode 2472MHz | | |
| Remark: | No report for the emission which more than 10 dB below the prescribed limit. | | |

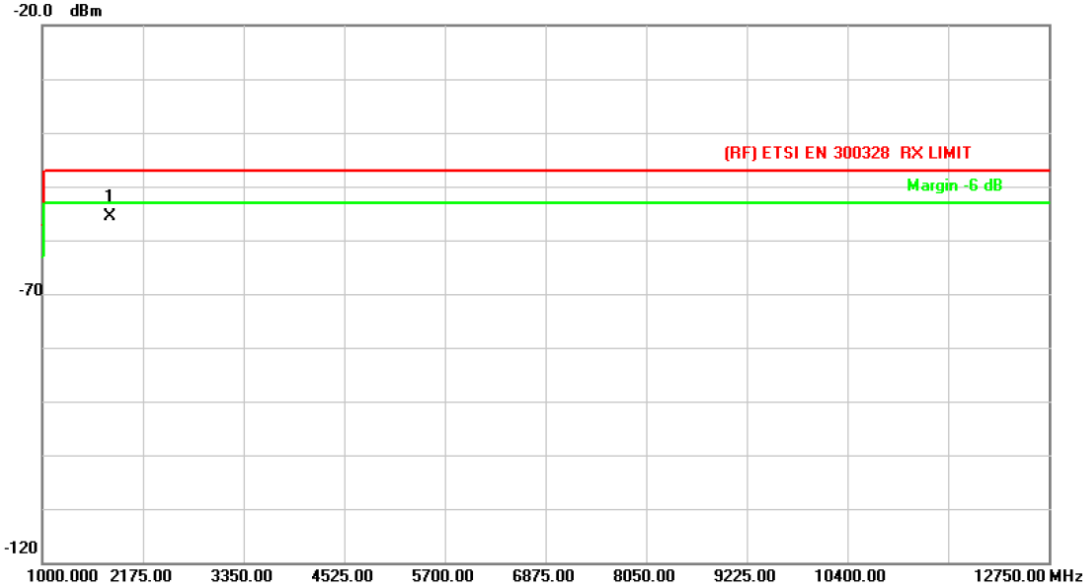

| No. | Mk. | Freq. | Reading Level | Correct Factor | Measurement | Limit | Over | Detector |
|-----|-----|----------|---------------|----------------|-------------|--------|-------|----------|
| | | MHz | dBm | dB | dBm | dBm | dB | |
| 1 | * | 1786.901 | -64.76 | 9.03 | -55.73 | -47.00 | -8.73 | peak |

- Remark:**
1. Corr. = Antenna Factor (dB/m) + Cable Loss (dB)
 2. Margin (dB) = Peak(dBm) - Limit (dBm)

Attachment H-- Receiver Blocking Test Data

| | | | |
|---------------|----------|--------------------|-----|
| Temperature: | 25 °C | Relative Humidity: | 55% |
| Test Voltage: | AC 230V | | |
| Test Mode: | 802.11 b | | |

Test Data

Receiver Categories: category 1 category 2 category 3

| Frequency (MHz) | Blocking Signal Power (dBm) | Wanted signal mean power from companion device (dBm) | Type of blocking signal | PER Result (%) | | Limit | Result |
|-----------------|-----------------------------|--|-------------------------|----------------|---------|-------|--------|
| | | | | 2412MHz | 2472MHz | | |
| 2380 | -32 | -68 | CW | 2.31 | 2.25 | 10 | Pass |
| 2504 | -32 | -68 | | 2.58 | 2.46 | 10 | Pass |
| 2300 | -32 | -74 | | 2.96 | 2.58 | 10 | Pass |
| 2330 | -32 | -74 | | 3.14 | 2.79 | 10 | Pass |
| 2360 | -32 | -74 | | 3.42 | 3.02 | 10 | Pass |
| 2524 | -32 | -74 | | 3.65 | 3.38 | 10 | Pass |
| 2584 | -32 | -74 | | 3.83 | 3.57 | 10 | Pass |
| 2674 | -32 | -74 | | 4.07 | 3.84 | 10 | Pass |

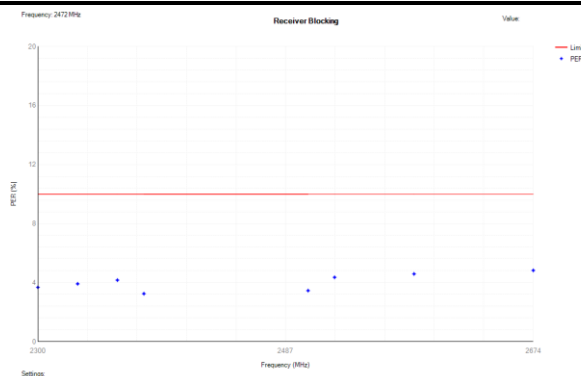
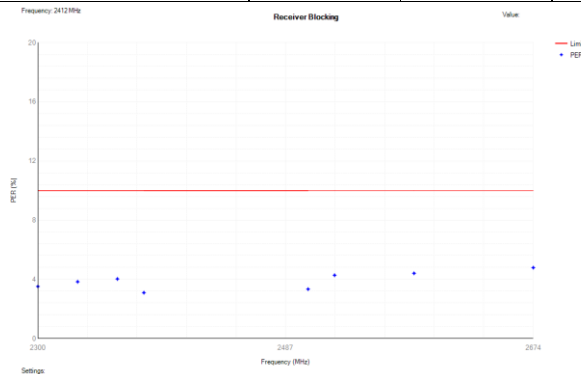

Note: Blocking Signal Power=-34dBm+G(dBi)

Wanted signal mean power is (-133 dBm + 10 × log₁₀(OCBW)) or -68 dBm whichever is less for Blocking signal Frequency(2380MHz, 2504MHz); (-139 dBm + 10 × log₁₀(OCBW)) or -74 dBm whichever is less for Blocking signal Frequency(2300MHz, 2330MHz, 2360MHz, 2524MHz, 2584MHz, 2674MHz). OCBW is in Hz.

| | | | |
|---------------|---------|--------------------|-----|
| Temperature: | 25 °C | Relative Humidity: | 55% |
| Test Voltage: | AC 230V | | |
| Test Mode: | 802.11g | | |

Test Data

Receiver Categories: category 1 category 2 category 3

| Frequency (MHz) | Blocking Signal Power (dBm) | Wanted signal mean power from companion device (dBm) | Type of blocking signal | PER Result (%) | | Limit | Result |
|-----------------|-----------------------------|--|-------------------------|----------------|---------|-------|--------|
| | | | | 2412MHz | 2472MHz | | |
| 2380 | -32 | -68 | CW | 2.26 | 2.19 | 10 | Pass |
| 2504 | -32 | -68 | | 2.41 | 2.42 | 10 | Pass |
| 2300 | -32 | -74 | | 2.68 | 2.68 | 10 | Pass |
| 2330 | -32 | -74 | | 2.95 | 2.93 | 10 | Pass |
| 2360 | -32 | -74 | | 3.24 | 3.18 | 10 | Pass |
| 2524 | -32 | -74 | | 3.53 | 3.47 | 10 | Pass |
| 2584 | -32 | -74 | | 3.71 | 3.61 | 10 | Pass |
| 2674 | -32 | -74 | | 3.96 | 3.95 | 10 | Pass |

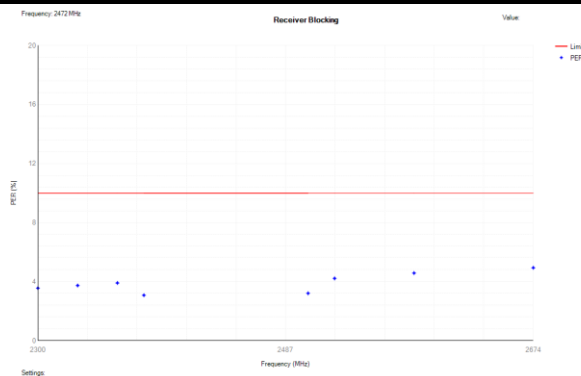
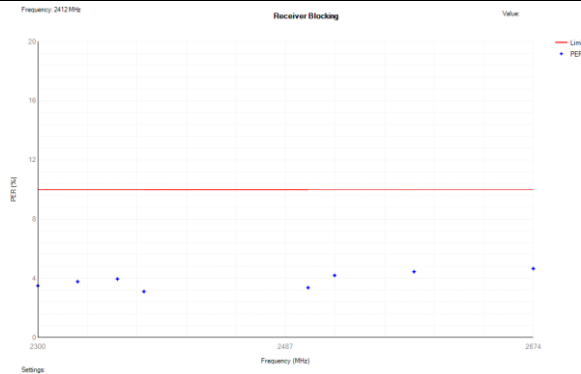

Note: Blocking Signal Power=-34dBm+G(dBi)
 Wanted signal mean power is (-133 dBm + 10 × log₁₀(OCBW)) or -68 dBm whichever is less for Blocking signal Frequency(2380MHz, 2504MHz); (-139 dBm + 10 × log₁₀(OCBW)) or -74 dBm whichever is less for Blocking signal Frequency(2300MHz, 2330MHz, 2360MHz, 2524MHz, 2584MHz, 2674MHz). OCBW is in Hz.

| | | | |
|---------------|---------------|--------------------|-----|
| Temperature: | 25 °C | Relative Humidity: | 55% |
| Test Voltage: | AC 230V | | |
| Test Mode: | 802.11n(HT20) | | |

Test Data

Receiver Categories: category 1 category 2 category 3

| Frequency (MHz) | Blocking Signal Power (dBm) | Wanted signal mean power from companion device (dBm) | Type of blocking signal | PER Result (%) | | Limit | Result |
|-----------------|-----------------------------|--|-------------------------|----------------|---------|-------|--------|
| | | | | 2412MHz | 2412MHz | | |
| 2380 | -32 | -68 | CW | 2.38 | 2.35 | 10 | Pass |
| 2504 | -32 | -68 | | 2.58 | 2.65 | 10 | Pass |
| 2300 | -32 | -74 | | 2.72 | 2.94 | 10 | Pass |
| 2330 | -32 | -74 | | 3.09 | 3.06 | 10 | Pass |
| 2360 | -32 | -74 | | 3.28 | 3.37 | 10 | Pass |
| 2524 | -32 | -74 | | 3.45 | 3.62 | 10 | Pass |
| 2584 | -32 | -74 | | 3.81 | 3.9 | 10 | Pass |
| 2674 | -32 | -74 | | 4.02 | 4.25 | 10 | Pass |

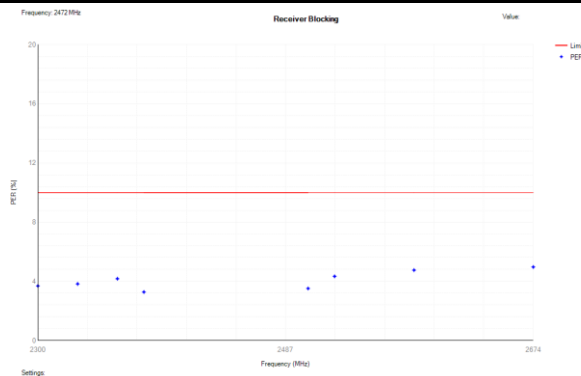
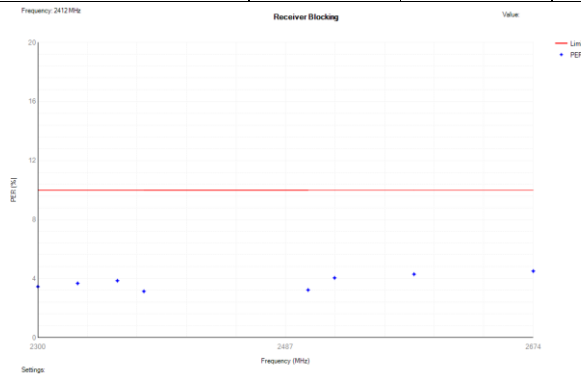

Note: Blocking Signal Power=-34dBm+G(dBi)
Wanted signal mean power is (-133 dBm + 10 × log₁₀(OCBW)) or -68 dBm whichever is less for Blocking signal Frequency(2380MHz, 2504MHz); (-139 dBm + 10 × log₁₀(OCBW)) or -74 dBm whichever is less for Blocking signal Frequency(2300MHz, 2330MHz, 2360MHz, 2524MHz, 2584MHz, 2674MHz). OCBW is in Hz.

-----END OF REPORT-----