

FCC Radio Test Report

FCC ID: 2AAH9-3700

Original Grant

Report No. : TB-FCC180402
Applicant : Navori Inc.
Equipment Under Test (EUT)
EUT Name : StiX
Model No. : 3700
Brand Name : Navori
Sample ID : TBBJ-20210325-18_01-1#&20210325-18_01-2#
Receipt Date : 2021-05-14
Test Date : 2021-05-14 to 2021-06-28
Issue Date : 2021-06-28
Standards : FCC Part 15, Subpart E 15.407
Test Method : ANSI C63.10: 2013
Conclusions : **PASS**

In the configuration tested, the EUT complied with the standards specified above,
The EUT technically complies with the FCC and IC requirements

Test/Witness Engineer :  Jack Deng

Test/Witness Engineer :  Ivan Su

Approved & Authorized :  Ray Lai



This report details the results of the testing carried out on one sample. The results contained in this test report do not relate to other samples of the same product. The manufacturer should ensure that all products in series production are in conformity with the product sample detailed in the report.

Contents

CONTENTS	2
1. GENERAL INFORMATION ABOUT EUT	5
1.1 Client Information.....	5
1.2 General Description of EUT (Equipment Under Test)	5
1.3 Block Diagram Showing the Configuration of System Tested.....	6
1.4 Description of Support Units	6
1.5 Description of Test Mode.....	6
1.6 Description of Test Software Setting	9
1.7 Measurement Uncertainty	10
1.8 Test Facility.....	10
2. TEST SUMMARY	11
3. TEST SOFTWARE	11
4. TEST EQUIPMENT	12
5. CONDUCTED EMISSION TEST	13
5.1 Test Standard and Limit.....	13
5.2 Test Setup.....	13
5.3 Test Procedure.....	14
5.4 Deviation From Test Standard.....	14
5.5 EUT Operating Mode	14
5.6 Test Data.....	14
6. RADIATED EMISSION TEST	15
6.1 Test Standard and Limit.....	15
6.2 Test Setup.....	16
6.3 Test Procedure.....	17
6.4 Deviation From Test Standard.....	18
6.5 EUT Operating Condition	18
6.6 Test Data.....	18
7. BAND EDGE EMISSIONS	19
7.1 Test Standard and Limit.....	19
7.2 Test Setup.....	19
7.3 Test Procedure.....	20
7.4 Deviation From Test Standard.....	21
7.5 EUT Operating Condition	21
7.6 Test Data.....	21
8. BANDWIDTH TEST	22
8.1 Test Standard and Limit.....	22
8.2 Test Setup.....	22
8.3 Test Procedure.....	22
8.4 Deviation From Test Standard.....	23

8.5 EUT Operating Condition	23
8.6 Test Data.....	23
9. OUTPUT POWER TEST	24
9.1 Test Standard and Limit.....	24
9.2 Test Setup.....	24
9.3 Test Procedure.....	24
9.4 Deviation From Test Standard.....	24
9.5 EUT Operating Condition	24
9.6 Test Date.....	24
10. POWER SPECTRAL DENSITY TEST	25
10.1 Test Standard and Limit	25
9.2 Test Setup.....	25
10.3 Test Procedure.....	25
10.4 Deviation From Test Standard.....	26
10.5 EUT Operating Condition	26
10.6 Test Data.....	26
11. FREQUENCY STABILITY MEASUREMENT.....	27
11.1 Test Standard and Limit	27
11.2 Test Setup.....	27
11.3 Test Procedure.....	27
11.4 Deviation From Test Standard.....	27
11.5 EUT Operating Condition	28
11.6 Test Data.....	28
12. ANTENNA REQUIREMENT.....	29
12.1 Standard Requirement.....	29
12.2 Antenna Connected Construction	29
12.3 Deviation From Test Standard.....	29
12.4 Result.....	29
ATTACHMENT A-- CONDUCTED EMISSION TEST DATA	30
ATTACHMENT B-- RADIATED EMISSION TEST DATA	32
ATTACHMENT C-- EMISSIONS IN RESTRICTED BANDS TEST DATA	46
ATTACHMENT D--BANDWIDTH TEST DATA.....	54
ATTACHMENT F-- POWER SPECTRAL DENSITY TEST DATA.....	63

1. General Information about EUT

1.1 Client Information

Applicant	:	Navori Inc.
Address	:	1000 rue Sherbrooke st W,Suite 710, Montreal, QC, Canada H3A 3G4
Manufacturer	:	Shenzhen MicoRose Technology Co., Ltd.
Address	:	8B2A, Daqing Building, southeast of the intersection of Shennan Road and Guangshen Expressway, Futian District, Shenzhen,China

1.2 General Description of EUT (Equipment Under Test)

EUT Name	:	StiX
Models No.	:	3700
Product Description	:	Operation Frequency: U-NII-1: 5180MHz~5240MHz, U-NII-3: 5745MHz~5825MHz
		Antenna Gain: 2.0dBi External Antenna
		Modulation Type: 802.11a: OFDM (QPSK, BPSK, 16QAM)
		Bit Rate of Transmitter: 802.11a: 6/9/12/18/24/36/48/54 Mbps
Power Rating	:	For Adapter: Input: 100-240V~ Output:5V $\overline{\text{---}}$, 2.5A
Software Version	:	android 9.0
Hardware Version	:	V1
Remark	:	The adapter and antenna gain provided by the applicant, the verified for the RF conduction test provided by TOBY test lab.

Note:

(1) This Test Report is FCC Part 15, Subpart E(15.407) for 802.11a/n/ac, the test procedure follows the KDB 789033 D02 General U-NII Test Procedures New Rules v02r01. More detailed features description, please refer to the manufacturer's specifications or the User's Manual.

(2) Channel List:

Frequency Band	Channel No.	Frequency	Channel No.	Frequency
5180~5240MHz (U-NII-1)	36	5180 MHz	44	5220 MHz
	40	5200 MHz	48	5240 MHz
For 20 MHz Bandwidth, use channel 36, 40, 44,48.				
Frequency Band	Channel No.	Frequency	Channel No.	Frequency
5745~5825MHz (U-NII-3)	149	5745 MHz	161	5805 MHz
	153	5765 MHz	165	5825 MHz
	157	5785 MHz		
For 20 MHz Bandwidth, use channel 149, 153, 157, 161, 165.				

1.3 Block Diagram Showing the Configuration of System Tested

Charging + TX Mode

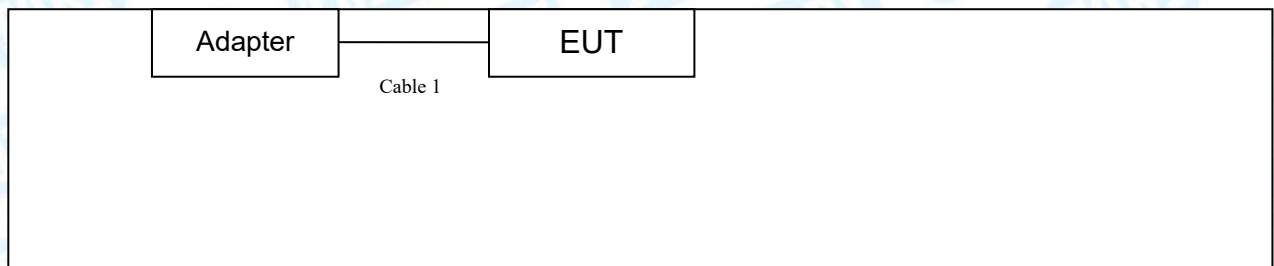

1.4 Description of Support Units

Equipment Information				
Name	Model	FCC ID/VOC	Manufacturer	Used “√”
DELL	U2720QM	----	Dell (China) Co., Ltd	√
Cable Information				
Number	Shielded Type	Ferrite Core	Length	Note
----	-----	----	-----	----

1.5 Description of Test Mode

To investigate the maximum EMI emission characteristics generates from EUT, the test system was pre-scanning tested base on the consideration of following EUT operation mode or test configuration mode which possible have effect on EMI emission level. Each of these EUT operation mode(s) or test configuration mode(s) mentioned follow was evaluated respectively.

For Conducted Test		
Final Test Mode	Description	
Mode 1	Charging + TX a Mode(5180MHz)	
For Radiated Test Below 1GHz		
Final Test Mode	Description	
Mode 2	Charging + TX a Mode(5180MHz)	
For Radiated Test Above 1GHz		
Test Band	Final Test Mode	Description
U-NII-1	Mode 3	TX Mode 802.11a Mode Channel 36/40/48
U-NII-3	Mode 4	TX Mode 802.11a Mode Channel 149/157/165

Note:

- (1) For all test, we have verified the construction and function in typical operation. And all the test modes were carried out with the EUT in transmitting operation in maximum power with all kinds of data rate.

According to ANSI C63.10 standards, the measurements are performed at the highest, middle, lowest available channels, and the worst case data rate as follows:

802.11a Mode: OFDM (6 Mbps)

- (2) During the testing procedure, the continuously transmitting with the maximum power mode was programmed by the customer.
- (3) The EUT is considered a portable unit; it was positioned on X-plane. The worst case was found positioned on X-plane. Therefore only the test data of this X-plane was used for radiated emission measurement test.

1.6 Description of Test Software Setting

During testing channel & Power controlling software provided by the customer was used to control the operating channel as well as the output power level. The RF output power selection is for the setting of RF output power expected by the customer and is going to be fixed on the firmware of the final end product power parameters of WLAN.

Test Software: LaunchEngmode		
Test Mode: Continuously transmitting		
U-NII-1		
Mode	Frequency (MHz)	Parameters
802.11a	5180	DEF
	5200	DEF
	5240	DEF
U-NII-3		
Mode	Frequency (MHz)	Parameters
802.11a	5745	DEF
	5785	DEF
	5825	DEF

1.7 Measurement Uncertainty

The reported uncertainty of measurement $y \pm U$, where expanded uncertainty U is based on a standard uncertainty multiplied by a coverage factor of $k=2$, providing a level of confidence of approximately 95 %.

Test Item	Parameters	Expanded Uncertainty (U_{Lab})
Conducted Emission	Level Accuracy: 9kHz~150kHz 150kHz to 30MHz	± 3.50 dB ± 3.10 dB
Radiated Emission	Level Accuracy: 9kHz to 30 MHz	± 4.60 dB
Radiated Emission	Level Accuracy: 30MHz to 1000 MHz	± 4.50 dB
Radiated Emission	Level Accuracy: Above 1000MHz	± 4.20 dB

1.8 Test Facility

The testing was performed by the Shenzhen Toby Technology Co., Ltd., in their facilities located at:1A/F., Bldg.6, Yusheng Industrial Zone, The National Road No.107 Xixiang Section 467, Xixiang, Bao'an, Shenzhen, Guangdong, China.

At the time of testing, the following bodies accredited the Laboratory:

CNAS (L5813)

The Laboratory has been accredited by CNAS to ISO/IEC 17025: 2005 General Requirements for the Competence of Testing and Calibration Laboratories for the competence in the field of testing. And the Registration No.: CNAS L5813.

A2LA Certificate No.: 4750.01

The laboratory has been accredited by American Association for Laboratory Accreditation(A2LA) to ISO/IEC 17025: 2005 General Requirements for the Competence of Testing and Calibration Laboratories for the technical competence in the field of Electrical Testing. And the A2LA Certificate No.: 4750.01.FCC Accredited Test Site Number: 854351.Designation Number:CN1223

IC Registration No.: (11950A)

The Laboratory has been registered by Certification and Engineering Bureau of Industry Canada for radio equipment testing. The site registration: Site# 11950A.

2. Test Summary

FCC Part 15 Subpart E(15.407)				
Standard Section FCC	Test Item	Test Sample(s)	Judgment	Remark
15.203	Antenna Requirement	TBBJ-20210325-18_01-1#	PASS	N/A
15.207	Conducted Emission	TBBJ-20210325-18_01-2#	PASS	N/A
15.407(b)	Band Edge Emissions	TBBJ-20210325-18_01-1#	PASS	N/A
15.407(a)	26dB Bandwidth&99% Bandwidth	TBBJ-20210325-18_01-1#	PASS	N/A
15.407(e)	6dB Bandwidth	TBBJ-20210325-18_01-1#	PASS	N/A
15.407(a)	AVG Output Power	TBBJ-20210325-18_01-1#	PASS	N/A
15.407(a)	Power Spectral Density	TBBJ-20210325-18_01-1#	PASS	N/A
15.209 15.407(b)	Transmitter Radiated Spurious Emission	TBBJ-20210325-18_01-1# TBBJ-20210325-18_01-2#	PASS	N/A
15.407(a)	Peak Excursion	TBBJ-20210325-18_01-1#	PASS	N/A
15.407(g)	Frequency Stability	TBBJ-20210325-18_01-1#	PASS	N/A
Note: "/" for no requirement for this test item. N/A is an abbreviation for Not Applicable.				

3. Test Software

Test Item	Test Software	Manufacturer	Version No.
Conducted Emission	EZ-EMC	EZ	CDI-03A2
Radiation Emission	EZ-EMC	EZ	FA-03A2RE
RF Conducted Measurement	MTS-8310	MWRfTest	V2.0.0.0

4. Test Equipment

Conducted Emission Test					
Equipment	Manufacturer	Model No.	Serial No.	Last Cal.	Cal. Due Date
EMI Test Receiver	Rohde & Schwarz	ESCI	100321	Jul. 06, 2020	Jul. 05, 2021
RF Switching Unit	Compliance Direction Systems Inc	RSU-A4	34403	Jul. 06, 2020	Jul. 05, 2021
AMN	SCHWARZBECK	NNBL 8226-2	8226-2/164	Jul. 06, 2020	Jul. 05, 2021
LISN	Rohde & Schwarz	ENV216	101131	Jul. 06, 2020	Jul. 05, 2021
Radiation Emission Test					
Equipment	Manufacturer	Model No.	Serial No.	Last Cal.	Cal. Due Date
Spectrum Analyzer	Agilent	E4407B	MY45106456	Jul. 06, 2020	Jul. 05, 2021
EMI Test Receiver	Rohde & Schwarz	ESPI	100010/007	Jul. 06, 2020	Jul. 05, 2021
Spectrum Analyzer	Rohde & Schwarz	FSV40-N	102197	Jul. 06, 2020	Jul. 05, 2021
Bilog Antenna	ETS-LINDGREN	3142E	00117537	Mar.01, 2020	Feb. 28, 2022
Horn Antenna	ETS-LINDGREN	3117	00143207	Mar.01, 2020	Feb. 28, 2022
Horn Antenna	ETS-LINDGREN	BBHA 9170	BBHA9170582	Mar.01, 2020	Feb. 28, 2022
Loop Antenna	SCHWARZBECK	FMZB 1519 B	1519B-059	Jul. 07, 2020	Jul. 06, 2021
Pre-amplifier	Sonoma	310N	185903	Feb.25, 2021	Feb. 24, 2022
Pre-amplifier	HP	8449B	3008A00849	Feb.25, 2021	Feb. 24, 2022
Pre-amplifier	SKET	LNPA_1840G-50	SK201904032	Feb.25, 2021	Feb. 24, 2022
Cable	HUBER+SUHNER	100	SUCOFLEX	Feb.25, 2021	Feb. 24, 2022
Positioning Controller	ETS-LINDGREN	2090	N/A	N/A	N/A
Antenna Conducted Emission					
Equipment	Manufacturer	Model No.	Serial No.	Last Cal.	Cal. Due Date
Spectrum Analyzer	Agilent	E4407B	MY45106456	Jul. 06, 2020	Jul. 05, 2021
Spectrum Analyzer	Rohde & Schwarz	ESPI	100010/007	Jul. 06, 2020	Jul. 05, 2021
MXA Signal Analyzer	Agilent	N9020A	MY49100060	Sep. 11, 2020	Sep. 10, 2021
Vector Signal Generator	Agilent	N5182A	MY50141294	Sep. 11, 2020	Sep. 10, 2021
Analog Signal Generator	Agilent	N5181A	MY50141953	Sep. 11, 2020	Sep. 10, 2021
RF Power Sensor	DARE!! Instruments	RadiPowerRPR3006W	17100015SNO26	Sep. 11, 2020	Sep. 10, 2021
	DARE!! Instruments	RadiPowerRPR3006W	17100015SNO29	Sep. 11, 2020	Sep. 10, 2021
	DARE!! Instruments	RadiPowerRPR3006W	17100015SNO31	Sep. 11, 2020	Sep. 10, 2021
	DARE!! Instruments	RadiPowerRPR3006W	17100015SNO33	Sep. 11, 2020	Sep. 10, 2021

5. Conducted Emission Test

5.1 Test Standard and Limit

5.1.1 Test Standard

FCC Part 15.207

5.1.2 Test Limit

Conducted Emission Test Limit

Frequency	Maximum RF Line Voltage (dB μ V)	
	Quasi-peak Level	Average Level
150kHz~500kHz	66 ~ 56 *	56 ~ 46 *
500kHz~5MHz	56	46
5MHz~30MHz	60	50

Notes:

- (1) *Decreasing linearly with logarithm of the frequency.
- (2) The lower limit shall apply at the transition frequencies.
- (3) The limit decrease in line with the logarithm of the frequency in the range of 0.15 to 0.50MHz.

5.2 Test Setup

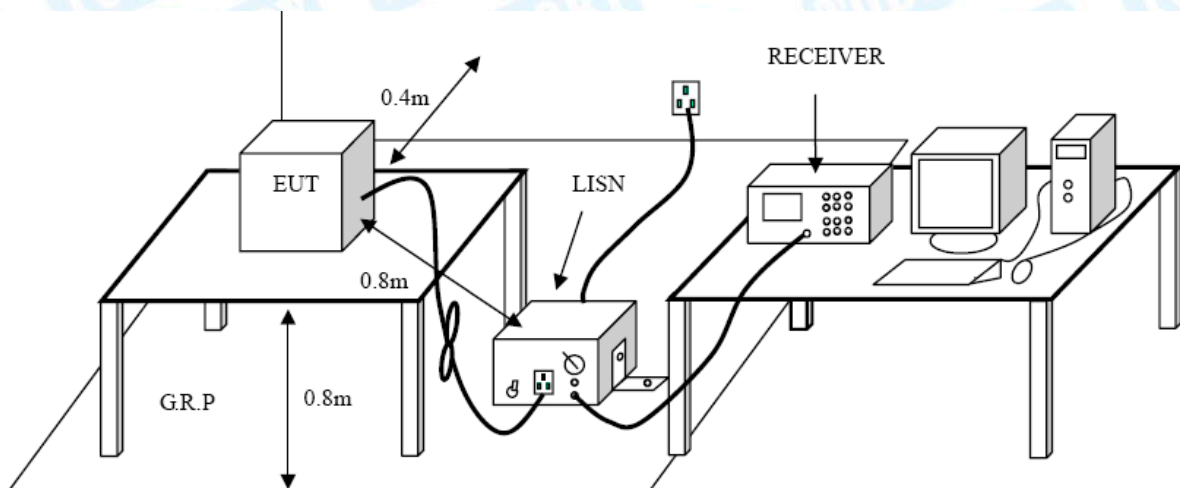

5.3 Test Procedure

The EUT was placed 0.8 meters from the horizontal ground plane with EUT being connected to the power mains through a line impedance stabilization network (LISN). All other support equipments powered from additional LISN(s). The LISN provide 50 Ohm/50uH of coupling impedance for the measuring instrument.

Interconnecting cables that hang closer than 40 cm to the ground plane shall be folded back and forth in the center forming a bundle 30 to 40 cm long.

I/O cables that are not connected to a peripheral shall be bundled in the center. The end of the cable may be terminated, if required, using the correct terminating impedance. The overall length shall not exceed 1 m.

LISN at least 80 cm from nearest part of EUT chassis.

The bandwidth of EMI test receiver is set at 9kHz, and the test frequency band is from 0.15MHz to 30MHz.

5.4 Deviation From Test Standard

No deviation

5.5 EUT Operating Mode

Please refer to the description of test mode.

5.6 Test Data

Please refer to the Attachment A.

6. Radiated Emission Test

6.1 Test Standard and Limit

6.1.1 Test Standard

FCC Part 15.209

6.1.2 Test Limit

Radiated Emission Limits (9kHz~1000MHz)

Frequency (MHz)	Field Strength (microvolt/meter)	Measurement Distance (meters)
0.009~0.490	2400/F(KHz)	300
0.490~1.705	24000/F(KHz)	30
1.705~30.0	30	30
30~88	100	3
88~216	150	3
216~960	200	3
Above 960	500	3

Radiated Emission Limit (Above 1000MHz)

Frequency (MHz)	Distance of 3m (dBuV/m)	
	Peak	Average
Above 1000	74	54

Note:

- (1) The tighter limit applies at the band edges.
- (2) Emission Level(dBuV/m)=20log Emission Level(uV/m)

Limits of unwanted emission out of the restricted bands

Frequency (MHz)	EIRP Limits (dBm)	Equivalent Field Strength at 3m (dBuV/m)
5150~5250	-27	68.3
5250~5350	-27	68.3
5470~5725	-27	68.3
5725~5825	-27(Note 2)	68.3
	10(Note 2)	105.3
	15.6(Note 2)	110.9
	27(Note 2)	122.3

NOTE:

1, The following formula is used to convert the equipment isotropic radiated power (eirp) to field strength:

$$E = \frac{1000000\sqrt{30P}}{3} \text{ uV/m, where P is the eirp (Watts)}$$

2, According to FCC 16-24, All emissions shall be limited to a level of -27 dBm/MHz at 75 MHz or more above or below the band edge increasing linearly to 10 dBm/MHz at 25 MHz above or below the band edge, and from 25MHz above or below the band edge increasing linearly to a level of 15.6 dBm/MHz at 5 MHz above or below the band edge, and from 5 MHz above or below the band edge increasing linearly to a level of 27dBm/MHz at the band edge.

6.2 Test Setup

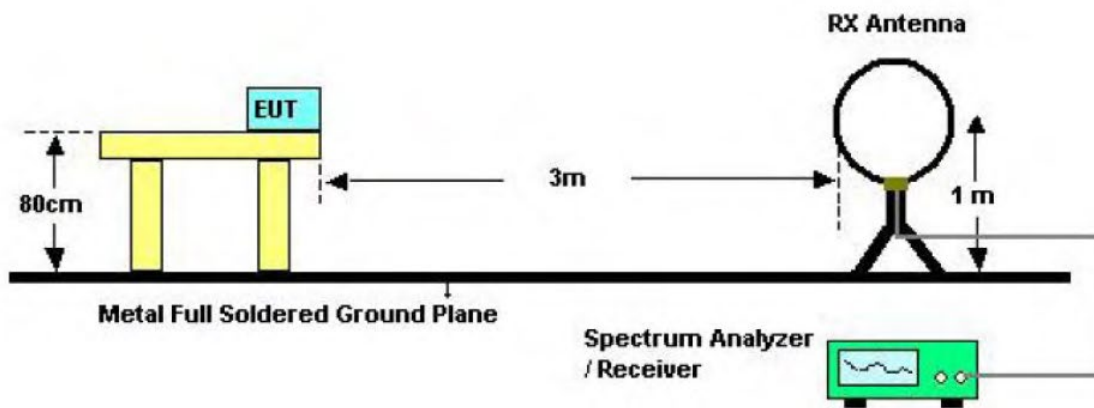

Below 30MHz Test Setup

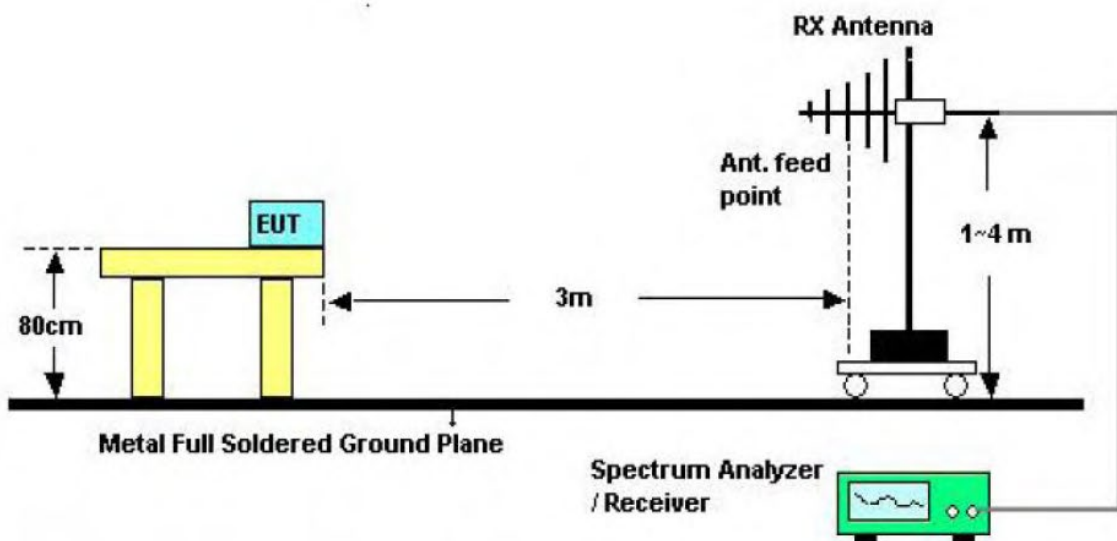

Below 1000MHz Test Setup



Above 1GHz Test Setup

6.3 Test Procedure

- (1) The measuring distance of 3m shall be used for measurements at frequency up to 1GHz. The EUT was placed on a rotating 0.8m high above the ground, the table was rotated 360 degrees to determine the position of the highest radiation.
- (2) Measurements at frequency above 1GHz. The EUT was placed on a rotating 1.5m high above the ground. RF absorbers covered the ground plane with a minimum area of 3.0m by 3.0m between the EUT and measurement receiver antenna. The RF absorber shall not exceed 30cm in high above the conducting floor. The table was rotated 360 degrees to determine the position of the highest radiation.
- (3) The Test antenna shall vary between 1m and 4m, Both Horizontal and Vertical Antenna 0re set to make measurement.
- (4) The initial step in collecting conducted emission data is a spectrum analyzer peak detector mode pre-scanning the measurement frequency range. Significant peaks are then marked and then Quasi Peak detector mode re-measured.
- (5) If the Peak Mode measured value compliance with and lower than Quasi Peak Mode Limit Bellow 1 GHz, the EUT shall be deemed to meet QP Limits and then no additional QP Mode measurement performed. But the Peak Value and average value both need to comply with applicable limit above 1 GHz.
- (6) Testing frequency range below 1GHz the measuring instrument use VBW=120 kHz with Quasi-peak detection.
- (7) Testing frequency range above 1GHz the measuring instrument use RBW=1 MHz and VBW=3 MHz with Peak Detector for Peak Values, and use RBW=1 MHz and VBW=10 Hz with Peak Detector for Average Values.
- (8) For the actual test configuration, please see the test setup photo.

6.4 Deviation From Test Standard

No deviation

6.5 EUT Operating Condition

The Equipment Under Test was set to Continual Transmitting in maximum power.

6.6 Test Data

Remark: During testing above 1GHz the measuring instrument use RBW=1 MHz and VBW=3 MHz with Peak Detector for Peak Values, and use RBW=1 MHz and VBW=10 Hz with Peak Detector for Average Values.

Please refer to the Attachment B.

7. Band Edge Emissions

7.1 Test Standard and Limit

7.1.1 Test Standard

FCC Part 15.407(b)

7.1.2 Test Limit

Limits of unwanted emission out of the restricted bands

Frequency (MHz)	EIRP Limits (dBm)	Equivalent Field Strength at 3m (dBuV/m)
5150~5250	-27	68.3
5250~5350	-27	68.3
5470~5725	-27	68.3
5725~5825	-27(Note 2)	68.3
	10(Note 2)	105.3
	15.6(Note 2)	110.9
	27(Note 2)	122.3

NOTE:

1, The following formula is used to convert the equipment isotropic radiated power (eirp) to field strength:

$$E = \frac{1000000\sqrt{30P}}{3} \text{ uV/m, where P is the eirp (Watts)}$$

2, According to FCC 16-24, All emissions shall be limited to a level of -27 dBm/MHz at 75 MHz or more above or below the band edge increasing linearly to 10 dBm/MHz at 25 MHz above or below the band edge, and from 25MHz above or below the band edge increasing linearly to a level of 15.6 dBm/MHz at 5 MHz above or below the band edge, and from 5 MHz above or below the band edge increasing linearly to a level of 27dBm/MHz at the band edge.

7.2 Test Setup

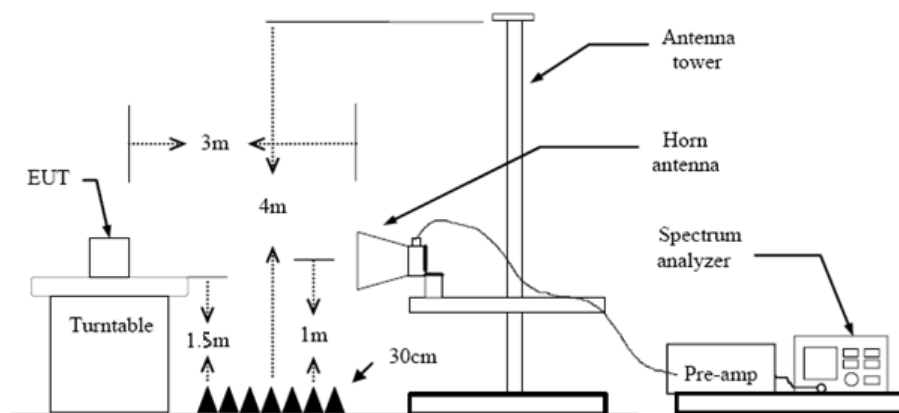

7.3 Test Procedure

---Radiated measurement

- Measurements at frequency above 1GHz. The EUT was placed on a rotating 1.5m high above the ground. RF absorbers covered the ground plane with a minimum area of 3.0m by 3.0m between the EUT and measurement receiver antenna. The RF absorber shall not exceed 30cm in high above the conducting floor. The table was rotated 360 degrees to determine the position of the highest radiation.
- The Test antenna shall vary between 1m and 4m, Both Horizontal and Vertical antenna are set to make measurement.
- The initial step in collecting conducted emission data is a spectrum analyzer peak detector mode pre-scanning the measurement frequency range. Significant peaks are then marked and then Quasi Peak detector mode re-measured.
- The Peak Value and average value both need to comply with applicable limit above 1 GHz.
- Testing frequency range above 1GHz the measuring instrument use RBW=1 MHz and VBW=3 MHz with Peak Detector for Peak Values, and use RBW=1 MHz and VBW=10 Hz with Peak Detector for Average Values.
- For the actual test configuration, please see the test setup photo.

--- Conducted measurement

- a) Measure the conducted output power (in dBm) using the detector specified by the appropriate regulatory agency (see 11.12.2.3 through 11.12.2.5 for guidance regarding measurement procedures for determining quasi-peak, peak, and average conducted output power, respectively).
- b) Add the maximum transmit antenna gain (in dBi) to the measured output power level to determine the EIRP (see 11.12.2.6 for guidance on determining the applicable antenna gain).
- c) Add the appropriate maximum ground reflection factor to the EIRP (6 dB for frequencies ≤ 30 MHz; 4.7 dB for frequencies between 30 MHz and 1000 MHz, inclusive; and 0 dB for frequencies > 1000 MHz).
- d) For MIMO devices, measure the power of each chain and sum the EIRP of all chains in linear terms (i.e., watts and mW).
- e) Convert the resultant EIRP to an equivalent electric field strength using the following relationship:
$$E = \text{EIRP} - 20 \log d + 104.8$$
where
E is the electric field strength in dBuV/m
EIRP is the equivalent isotropically radiated power in dBm
d is the specified measurement distance in m
- f) Compare the resultant electric field strength level with the applicable regulatory limit.
- g) Perform the radiated spurious emission test.

7.4 Deviation From Test Standard

No deviation

7.5 EUT Operating Condition

The Equipment Under Test was set to Continual Transmitting in maximum power.

7.6 Test Data

Please refer to the Attachment C.

8. Bandwidth Test

8.1 Test Standard and Limit

8.1.1 Test Standard

FCC Part 15.407

8.1.2 Test Limit

FCC Part 15 Subpart C(15.407)		
Test Item	Limit	Frequency Range (MHz)
26 Bandwidth	N/A	5150~5250
		5250~5350
		5500~5700
6 dB Bandwidth	>500kHz	5725~5850

8.2 Test Setup

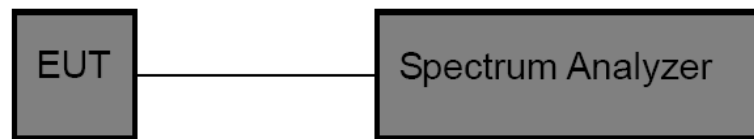

8.3 Test Procedure

- (1) The EUT was directly connected to the spectrum analyzer and antenna output port as show in the block diagram above.
- (2) The setting of the spectrum analyser as below:

26dB Bandwidth Test	
Spectrum Parameters	Setting
Attenuation	Auto
Span	>26 dB Bandwidth
RBW	Approximately 1% of the emission bandwidth
VBW	VBW>RBW
Detector	Peak
Trace	Max Hold
Sweep Time	Auto

6dB Bandwidth Test	
Spectrum Parameters	Setting
Attenuation	Auto
Span	>6 dB Bandwidth
RBW	100 kHz
VBW	VBW>=3*RBW
Detector	Peak
Trace	Max Hold
Sweep Time	Auto
99% Occupied Bandwidth Test	
Spectrum Parameters	Setting
Attenuation	Auto
RBW	1% to 5% of the OBW
VBW	≥ 3RBW
Detector	Peak
Trace	Max Hold

8.4 Deviation From Test Standard

No deviation

8.5 EUT Operating Condition

The EUT was set to continuously transmitting in each mode and low, Middle and high channel for the test.

8.6 Test Data

Please refer to the Attachment D.

9. Output Power Test

9.1 Test Standard and Limit

9.1.1 Test Standard

FCC Part 15.407 (a)

9.1.2 Test Limit

FCC Part 15 Subpart E(15.407)		
Test Item	Limit	Frequency Range(MHz)
Conducted Output Power	Fixed: 1 Watt (30dBm) Mobile and Portable: 250mW (24dBm)	5150~5250
	250mW (24dBm)	5250~5350
	250mW (24dBm)	5500~5700
	1 Watt (30dBm)	5725~5850

9.2 Test Setup

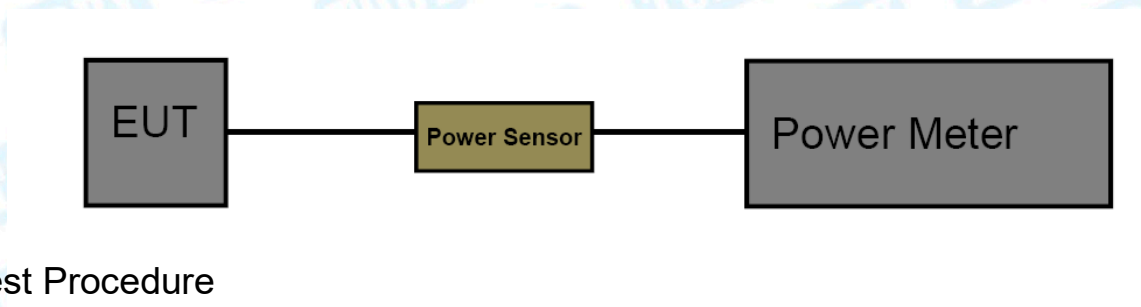

9.3 Test Procedure

The measurement is according to section 3 of KDB 789033 D02 General U-NII Test Procedures New Rules v02r01.

The EUT was connected to RF power meter via a broadband power sensor as show the block above.

9.4 Deviation From Test Standard

No deviation

9.5 EUT Operating Condition

The EUT was set to continuously transmitting in the max power during the test.

9.6 Test Date

Please refer to the Attachment E.

10. Power Spectral Density Test

10.1 Test Standard and Limit

10.1.1 Test Standard

FCC Part 15.407 (a)

10.1.2 Test Limit

FCC Part 15 Subpart E(15.407)		
Test Item	Limit	Frequency Range(MHz)
Power Spectral Density	Other than Mobile and Portable : 17dBm/MHz Mobile and Portable : 11dBm/MHz	5150~5250
	11dBm/MHz	5250~5350
	11dBm/MHz	5500~5700
	30dBm/500kHz	5725~5850

9.2 Test Setup

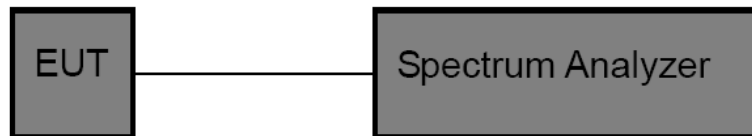

10.3 Test Procedure

The EUT was directly connected to the Spectrum Analyzer and antenna output port as show in the block diagram above. The measurement is according to KDB 789033 D02 General U-NII Test Procedures New Rules v02r01.

- (1) The EUT was directly connected to the spectrum analyzer and antenna output port as show in the block diagram above.
- (2) Set analyser centre frequency to transmitting frequency.
- (3) Set the span to encompass the entire emissions bandwidth (EBW)(alternatively, the entire 99% OBW) of the signal.
- (4) Set the RBW to: 1 MHz
- (5) Set the VBW to: 3 MHz
- (6) Detector: RMS
- (7) Trace: Max Hold
- (7) Sweep time: auto
- (8) Trace average at least 100 traces in power averaging.

- (9) Use the peak marker function to determine the maximum amplitude level within the RBW. Apply correction to the result if different RBW is used.

10.4 Deviation From Test Standard

No deviation

10.5 EUT Operating Condition

The EUT was set to continuously transmitting in each mode and low, Middle and high channel for the test.

10.6 Test Data

Please refer to the Attachment F.

11. Frequency Stability Measurement

11.1 Test Standard and Limit

11.1.1 Test Standard

FCC Part 15.407

11.1.2 Test Limit

FCC Part 15 Subpart C(15.407)		
Test Item	Limit	Frequency Range(MHz)
Peak Excursion Measurement	Manufacturers of U-NII devices are responsible for ensuring frequency stability such that an emission is maintained within the band of operation under all conditions of normal operation as specified in the users manual	5150~5250
		5250~5350
		5500~5700
		5725~5850

11.2 Test Setup

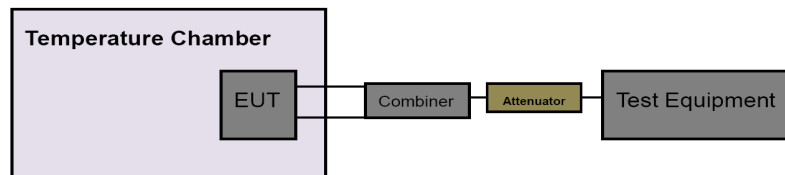

11.3 Test Procedure

The EUT was directly connected to the Spectrum Analyzer and antenna output port as show in the block diagram above.

- (1) The EUT was directly connected to the spectrum analyzer and antenna output port as show in the block diagram above.
- (2) Set analyser centre frequency to transmitting frequency.
- (3) Set the span to encompass the entire emissions bandwidth (EBW) of the signal.
- (4) Set the RBW to: 10 kHz, VBW=10 kHz with peak detector and maxhold settings.
- (5) The test extreme voltage is to change the primary supply voltage from 85 to 115 percent of the nominal value.
- (6) Extreme temperature is 0°C~50°C

11.4 Deviation From Test Standard

No deviation

11.5 EUT Operating Condition

The EUT was set to continuously transmitting in continuously un-modulation transmitting mode.

11.6 Test Data

Please refer to the Attachment G.

12. Antenna Requirement

12.1 Standard Requirement

12.1.1 Standard

FCC Part 15.203

12.1.2 Requirement

An intentional radiator shall be designed to ensure that no antenna other than that furnished by the responsible party shall be used with the device. The use of a permanently attached antenna or of an antenna that uses a unique coupling to the intentional radiator shall be considered sufficient to comply with the provisions of this Section. The manufacturer may design the unit so that a broken antenna can be replaced by the user, but the use of a standard antenna jack or electrical connector is prohibited.

12.2 Antenna Connected Construction

The gains of the antenna used for transmitting is 1.15dBi, and the antenna de-signed with permanent attachment and no consideration of replacement. Please see the EUT photo for details.

12.3 Deviation From Test Standard

No deviation

12.4 Result

The EUT antennas are FPC Antenna. It complies with the standard requirement.

Antenna Type
<input type="checkbox"/> Permanent attached antenna
<input checked="" type="checkbox"/> Unique connector antenna
<input type="checkbox"/> Professional installation antenna

Attachment A-- Conducted Emission Test Data

Remark: All channels have been tested and Shows only the worst channels.

Temperature:	24.8 °C	Relative Humidity:	42%
Test Voltage:	AC 120V/60 Hz		
Terminal:	Line		
Test Mode:	TX 802.11a Mode CH36		
Remark:	Only worse case is reported.		

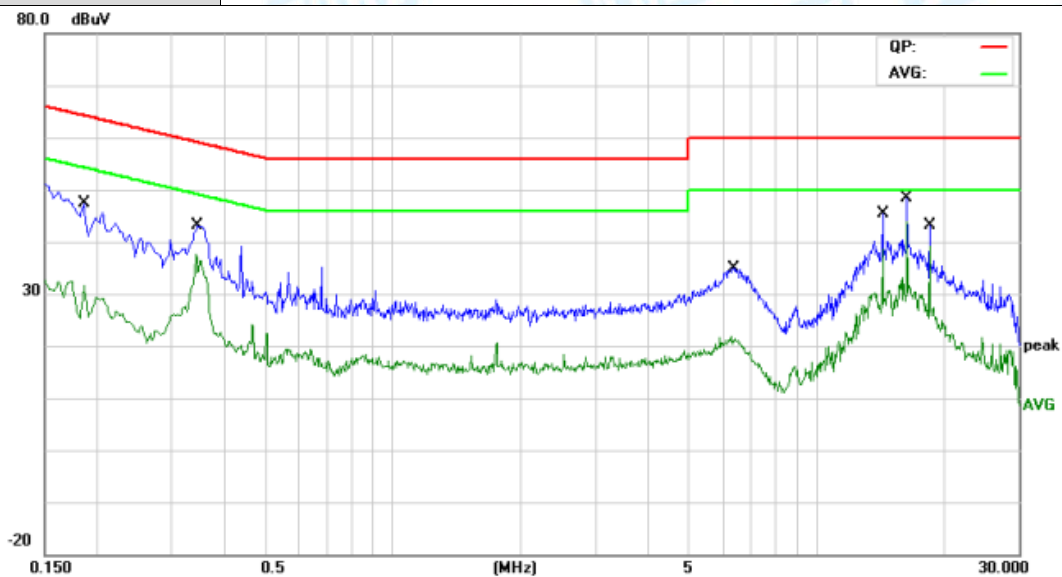

No.	Mk.	Freq. MHz	Reading Level dBuV	Correct Factor dB	Measure- ment dBuV	Limit dBuV	Over dB	Detector
1		0.1860	32.72	9.70	42.42	64.21	-21.79	QP
2		0.1860	18.08	9.70	27.78	54.21	-26.43	AVG
3		0.3460	30.24	9.70	39.94	59.06	-19.12	QP
4		0.3460	22.66	9.70	32.36	49.06	-16.70	AVG
5		6.3580	19.86	9.83	29.69	60.00	-30.31	QP
6		6.3580	10.29	9.83	20.12	50.00	-29.88	AVG
7		14.3380	33.38	9.97	43.35	60.00	-16.65	QP
8		14.3380	28.37	9.97	38.34	50.00	-11.66	AVG
9		16.3860	36.22	10.00	46.22	60.00	-13.78	QP
10	*	16.3860	33.60	10.00	43.60	50.00	-6.40	AVG
11		18.4340	31.64	10.00	41.64	60.00	-18.36	QP
12		18.4340	29.16	10.00	39.16	50.00	-10.84	AVG

*:Maximum data x:Over limit !:over margin

Emission Level= Read Level+ Correct Factor

Temperature:	24.8 °C	Relative Humidity:	42%
Test Voltage:	AC 120V/60 Hz		
Terminal:	Neutral		
Test Mode:	TX 802.11a Mode CH36		
Remark:	Only worse case is reported		

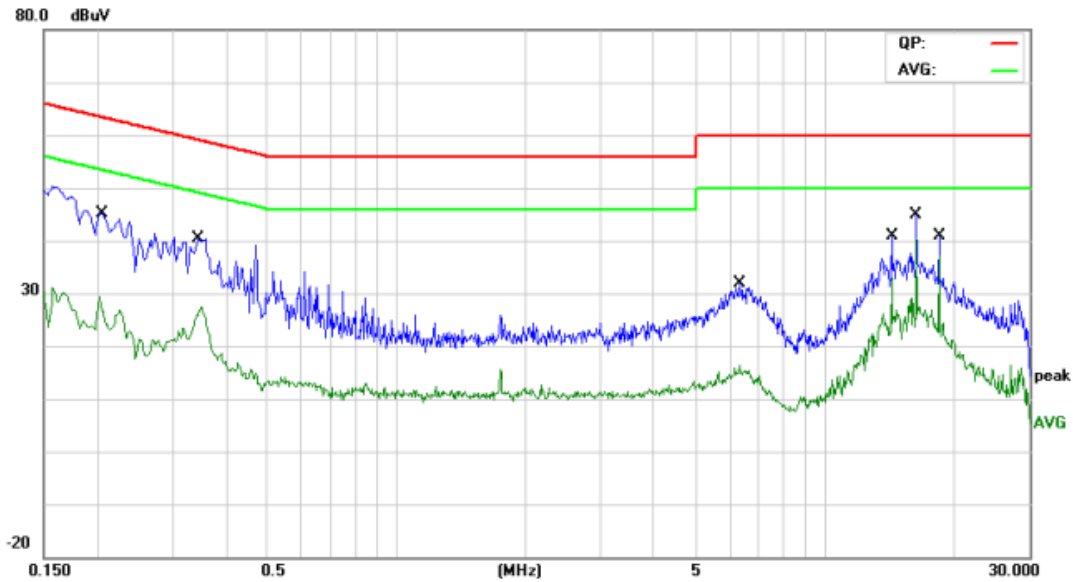

No.	Mk.	Freq.	Reading Level	Correct Factor	Measurement	Limit	Over	Detector
		MHz	dBuV	dB	dBuV	dBuV	dB	
1		0.2060	31.21	9.80	41.01	63.36	-22.35	QP
2		0.2060	14.25	9.80	24.05	53.36	-29.31	AVG
3		0.3460	25.43	9.80	35.23	59.06	-23.83	QP
4		0.3460	15.99	9.80	25.79	49.06	-23.27	AVG
5		6.3340	14.52	9.87	24.39	60.00	-35.61	QP
6		6.3340	5.43	9.87	15.30	50.00	-34.70	AVG
7		14.3380	29.51	9.99	39.50	60.00	-20.50	QP
8		14.3380	23.83	9.99	33.82	50.00	-16.18	AVG
9		16.3860	33.84	10.00	43.84	60.00	-16.16	QP
10	*	16.3860	30.23	10.00	40.23	50.00	-9.77	AVG
11		18.4340	28.70	10.00	38.70	60.00	-21.30	QP
12		18.4340	25.80	10.00	35.80	50.00	-14.20	AVG

*:Maximum data x:Over limit !:over margin

Emission Level= Read Level+ Correct Factor

Attachment B-- Radiated Emission Test Data

9 KHz~30 MHz

From 9 KHz to 30 MHz: Conclusion: PASS

Note: The amplitude of spurious emissions which are attenuated by more than 20dB below the permissible value has no need to be reported.

30MHz~1GHz

Temperature:	24.6 °C	Relative Humidity:	43%
Test Voltage:	AC 120V/60Hz		
Ant. Pol.	Horizontal		
Test Mode:	TX 802.11a Mode 5180MHz (U-NII-1)		
Remark:	Only worse case is reported		

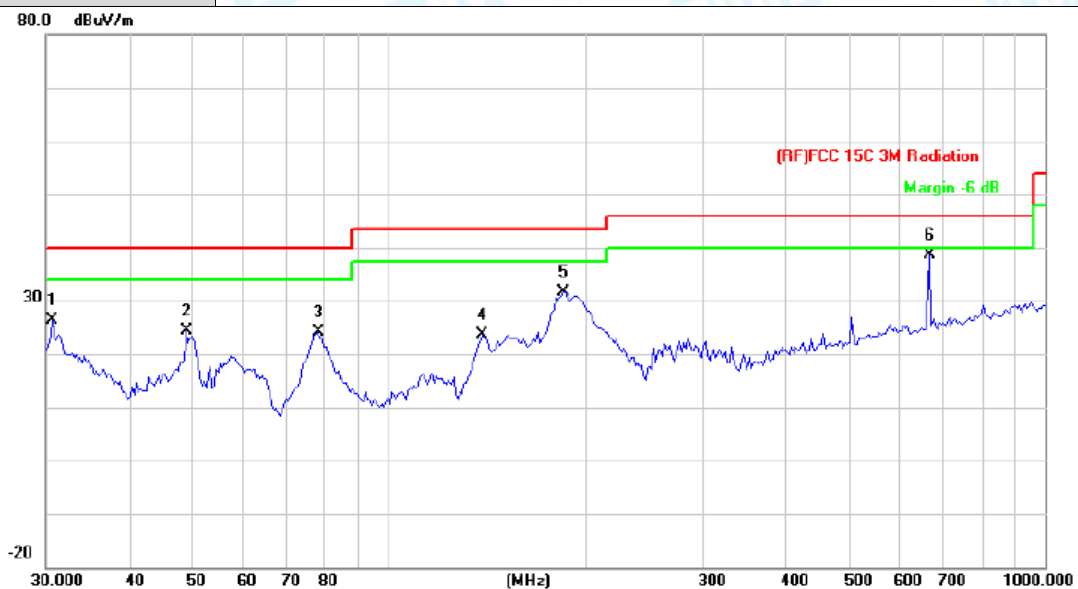

No. Mk.	Freq. MHz	Reading Level dBuV	Correct Factor dB/m	Measure- ment dBuV/m	Limit dBuV/m	Over dB	Detector
1	30.6379	39.83	-13.43	26.40	40.00	-13.60	QP
2	49.0145	47.22	-22.74	24.48	40.00	-15.52	QP
3	77.8654	46.69	-22.66	24.03	40.00	-15.97	QP
4	138.3873	45.91	-22.37	23.54	43.50	-19.96	QP
5	184.4898	51.51	-19.98	31.53	43.50	-11.97	QP
6	* 665.8035	46.29	-7.59	38.70	46.00	-7.30	QP

*:Maximum data x:Over limit !:over margin

Emission Level= Read Level+ Correct Factor

Temperature:	24.6 °C	Relative Humidity:	43%
Test Voltage:	AC 120V/60Hz		
Ant. Pol.	Vertical		
Test Mode:	TX 802.11a Mode 5180MHz (U-NII-1)		
Remark:	Only worse case is reported.		

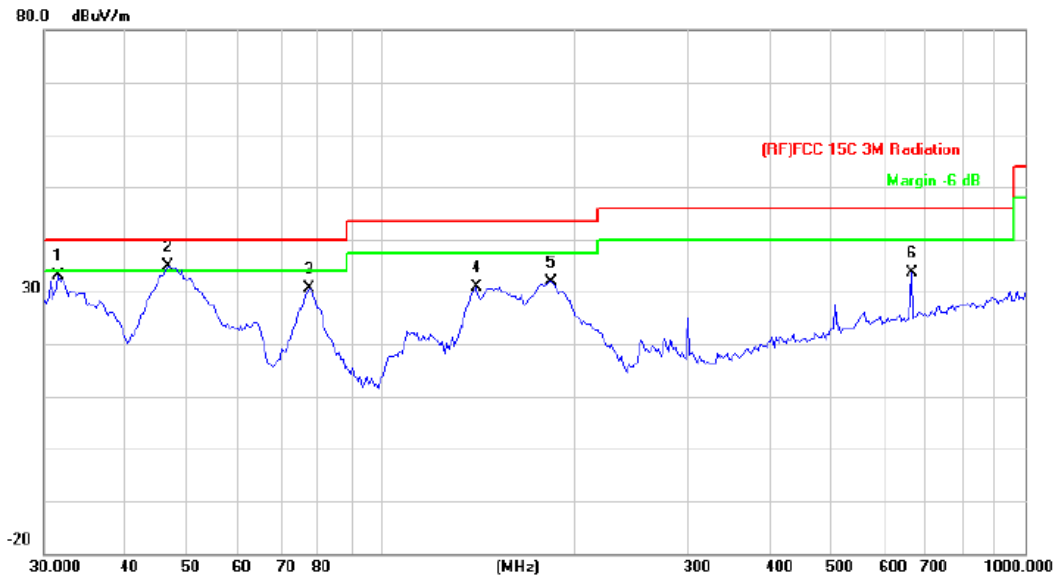

No.	Mk.	Freq. MHz	Reading Level dBuV	Correct Factor dB/m	Measure- ment dBuV/m	Limit dBuV/m	Over dB	Detector
1		31.5095	47.10	-14.08	33.02	40.00	-6.98	QP
2	*	46.6664	56.91	-21.96	34.95	40.00	-5.05	QP
3		77.3212	53.39	-22.71	30.68	40.00	-9.32	QP
4		140.3421	53.19	-22.35	30.84	43.50	-12.66	QP
5		183.2005	51.92	-20.01	31.91	43.50	-11.59	QP
6		665.8035	41.19	-7.59	33.60	46.00	-12.40	QP

*:Maximum data x:Over limit !:over margin

Emission Level= Read Level+ Correct Factor

5180MHz-5240MHz(U-NII-1)

Temperature:	25 °C	Relative Humidity:	55%
Test Voltage:	AC 120V/60 Hz		
Ant. Pol.	Horizontal		
Test Mode:	TX 802.11a Mode 5180MHz (U-NII-1)		
Remark:	No report for the emission which more than 10 dB below the prescribed limit. Only worse case is reported.		

No.	Mk.	Freq.	Reading Level	Correct Factor	Measurement	Limit	Over	Detector
		MHz	dBuV	dB/m	dBuV/m	dBuV/m	dB	
1	*	10359.171	24.41	20.50	44.91	54.00	-9.09	AVG
2		10359.735	34.88	20.50	55.38	68.30	-12.92	peak

Emission Level= Read Level+ Correct Factor

Temperature:	25 °C	Relative Humidity:	55%
Test Voltage:	AC 120V/60 Hz		
Ant. Pol.	Vertical		
Test Mode:	TX 802.11a Mode 5180MHz (U-NII-1)		
Remark:	No report for the emission which more than 10 dB below the prescribed limit. Only worse case is reported.		

No.	Mk.	Freq.	Reading Level	Correct Factor	Measurement	Limit	Over	Detector
		MHz	dBuV	dB/m	dBuV/m	dBuV/m	dB	
1	*	10360.949	23.73	20.50	44.23	54.00	-9.77	AVG
2		10361.011	34.61	20.50	55.11	68.30	-13.19	peak

Emission Level= Read Level+ Correct Factor

Temperature:	25 °C	Relative Humidity:	55%
Test Voltage:	AC 120V/60 Hz		
Ant. Pol.	Horizontal		
Test Mode:	TX 802.11a Mode 5200MHz (U-NII-1)		
Remark:	No report for the emission which more than 10 dB below the prescribed limit.		

No.	Mk.	Freq.	Reading Level	Correct Factor	Measurement	Limit	Over	Detector
		MHz	dBuV	dB/m	dBuV/m	dBuV/m	dB	
1	*	10399.738	23.32	20.56	43.88	54.00	-10.12	AVG
2		10401.421	33.84	20.56	54.40	68.30	-13.90	peak

Emission Level= Read Level+ Correct Factor

Temperature:	25 °C	Relative Humidity:	55%
Test Voltage:	AC 120V/60 Hz		
Ant. Pol.	Vertical		
Test Mode:	TX 802.11a Mode 5200MHz (U-NII-1)		
Remark:	No report for the emission which more than 10 dB below the prescribed limit.		

No.	Mk.	Freq.	Reading Level	Correct Factor	Measurement	Limit	Over	
		MHz	dBuV	dB/m	dBuV/m	dBuV/m	dB	Detector
1	*	10399.377	38.08	20.56	58.64	68.30	-9.66	peak
2		10399.377	19.80	20.56	40.36	54.00	-13.64	AVG

Emission Level= Read Level+ Correct Factor

Temperature:	25 °C	Relative Humidity:	55%
Test Voltage:	AC 120V/60 Hz		
Ant. Pol.	Horizontal		
Test Mode:	TX 802.11a Mode 5240MHz (U-NII-1)		
Remark:	No report for the emission which more than 10 dB below the prescribed limit.		

No.	Mk.	Freq.	Reading Level	Correct Factor	Measurement	Limit	Over	
		MHz	dBuV	dB/m	dBuV/m	dBuV/m	dB	Detector
1	*	10479.838	23.55	20.68	44.23	54.00	-9.77	AVG
2		10481.708	34.25	20.68	54.93	68.30	-13.37	peak

Emission Level= Read Level+ Correct Factor

Temperature:	25 °C	Relative Humidity:	55%
Test Voltage:	AC 120V/60 Hz		
Ant. Pol.	Vertical		
Test Mode:	TX 802.11a Mode 5240MHz (U-NII-1)		
Remark:	No report for the emission which more than 10 dB below the prescribed limit.		

No.	Mk.	Freq.	Reading Level	Correct Factor	Measurement	Limit	Over	
		MHz	dBuV	dB/m	dBuV/m	dBuV/m	dB	Detector
1		10480.125	34.14	20.68	54.82	68.30	-13.48	peak
2	*	10481.733	23.45	20.68	44.13	54.00	-9.87	AVG

Emission Level= Read Level+ Correct Factor

5745MHz-5825MHz(U-NII-3)

Temperature:	25 °C	Relative Humidity:	55%
Test Voltage:	AC 120V/60 Hz		
Ant. Pol.	Horizontal		
Test Mode:	TX 802.11a Mode 5745MHz (U-NII-3)		
Remark:	No report for the emission which more than 10 dB below the prescribed limit.		

No.	Mk.	Freq.	Reading Level	Correct Factor	Measurement	Limit	Over	Detector
		MHz	dBuV	dB/m	dBuV/m	dBuV/m	dB	
1	*	11488.631	19.73	21.81	41.54	54.00	-12.46	AVG
2		11488.930	29.68	21.81	51.49	68.30	-16.81	peak

Emission Level= Read Level+ Correct Factor

Temperature:	25 °C	Relative Humidity:	55%
Test Voltage:	AC 120V/60 Hz		
Ant. Pol.	Vertical		
Test Mode:	TX 802.11a Mode 5745MHz (U-NII-3)		
Remark:	No report for the emission which more than 10 dB below the prescribed limit.		

No.	Mk.	Freq.	Reading Level	Correct Factor	Measurement	Limit	Over	Detector
		MHz	dBuV	dB/m	dBuV/m	dBuV/m	dB	
1	*	11488.661	19.56	21.81	41.37	54.00	-12.63	AVG
2		11488.945	30.63	21.81	52.44	68.30	-15.86	peak

Emission Level= Read Level+ Correct Factor

Temperature:	25 °C	Relative Humidity:	55%
Test Voltage:	AC 120V/60 Hz		
Ant. Pol.	Horizontal		
Test Mode:	TX 802.11a Mode 5785MHz (U-NII-3)		
Remark:	No report for the emission which more than 10 dB below the prescribed limit.		

No.	Mk.	Freq.	Reading Level	Correct Factor	Measurement	Limit	Over	
		MHz	dBuV	dB/m	dBuV/m	dBuV/m	dB	Detector
1	*	11569.147	20.68	21.88	42.56	54.00	-11.44	AVG
2		11570.883	30.73	21.88	52.61	68.30	-15.69	peak

Emission Level= Read Level+ Correct Factor

Temperature:	25 °C	Relative Humidity:	55%
Test Voltage:	AC 120V/60 Hz		
Ant. Pol.	Vertical		
Test Mode:	TX 802.11a Mode 5785MHz (U-NII-3)		
Remark:	No report for the emission which more than 10 dB below the prescribed limit.		

No.	Mk.	Freq.	Reading Level	Correct Factor	Measurement	Limit	Over	Detector
		MHz	dBuV	dB/m	dBuV/m	dBuV/m	dB	
1	*	11569.454	21.89	21.88	43.77	54.00	-10.23	AVG
2		11571.496	30.98	21.88	52.86	68.30	-15.44	peak

Emission Level= Read Level+ Correct Factor

Temperature:	25 °C	Relative Humidity:	55%
Test Voltage:	AC 120V/60 Hz		
Ant. Pol.	Horizontal		
Test Mode:	TX 802.11a Mode 5825MHz (U-NII-3)		
Remark:	No report for the emission which more than 10 dB below the prescribed limit.		

No.	Mk.	Freq.	Reading Level	Correct Factor	Measurement	Limit	Over	
		MHz	dBuV	dB/m	dBuV/m	dBuV/m	dB	Detector
1	*	11648.818	19.63	21.96	41.59	54.00	-12.41	AVG
2		11650.973	31.09	21.96	53.05	68.30	-15.25	peak

Emission Level= Read Level+ Correct Factor

Temperature:	25 °C	Relative Humidity:	55%
Test Voltage:	AC 120V/60 Hz		
Ant. Pol.	Vertical		
Test Mode:	TX 802.11a Mode 5825MHz (U-NII-3)		
Remark:	No report for the emission which more than 10 dB below the prescribed limit.		

No.	Mk.	Freq. MHz	Reading Level dBuV	Correct Factor dB/m	Measure- ment dBuV/m	Limit dBuV/m	Over dB	Detector
1		11648.818	29.90	21.96	51.86	68.30	-16.44	peak
2	*	11650.052	21.49	21.96	43.45	54.00	-10.55	AVG

Emission Level= Read Level+ Correct Factor

Attachment C-- Emissions in Restricted Bands Test Data

Mode	Frequency (MHz)	Antenna	Spur Freq (MHz)	Power (dBm)	Gain (dBi)	E (dBuV/m)	Detector	Limit (dBuV/m)	Verdict
a	5180	Ant1	4500	-44.65	2	52.58	Peak	68.2	Pass
a	5180	Ant1	4500	-54.78	2	42.45	Average	54	Pass
a	5180	Ant1	5142.6	-36.18	2	61.05	Peak	68.2	Pass
a	5180	Ant1	5020.1	-50.34	2	46.89	Average	54	Pass
a	5180	Ant1	5150	-40.03	2	57.2	Peak	68.2	Pass
a	5180	Ant1	5150	-50.24	2	46.99	Average	54	Pass
a	5240	Ant1	5350	-43.89	2	53.34	Peak	68.2	Pass
a	5240	Ant1	5350	-53.88	2	43.35	Average	54	Pass
a	5240	Ant1	5352.72	-40.59	2	56.64	Peak	68.2	Pass
a	5240	Ant1	5392.8	-52.21	2	45.02	Average	54	Pass
a	5240	Ant1	5460	-43.44	2	53.79	Peak	68.2	Pass
a	5240	Ant1	5460	-54.21	2	43.02	Average	54	Pass

Test Graphs
Restrict Band NVNT a 5180MHz Ant1 Peak

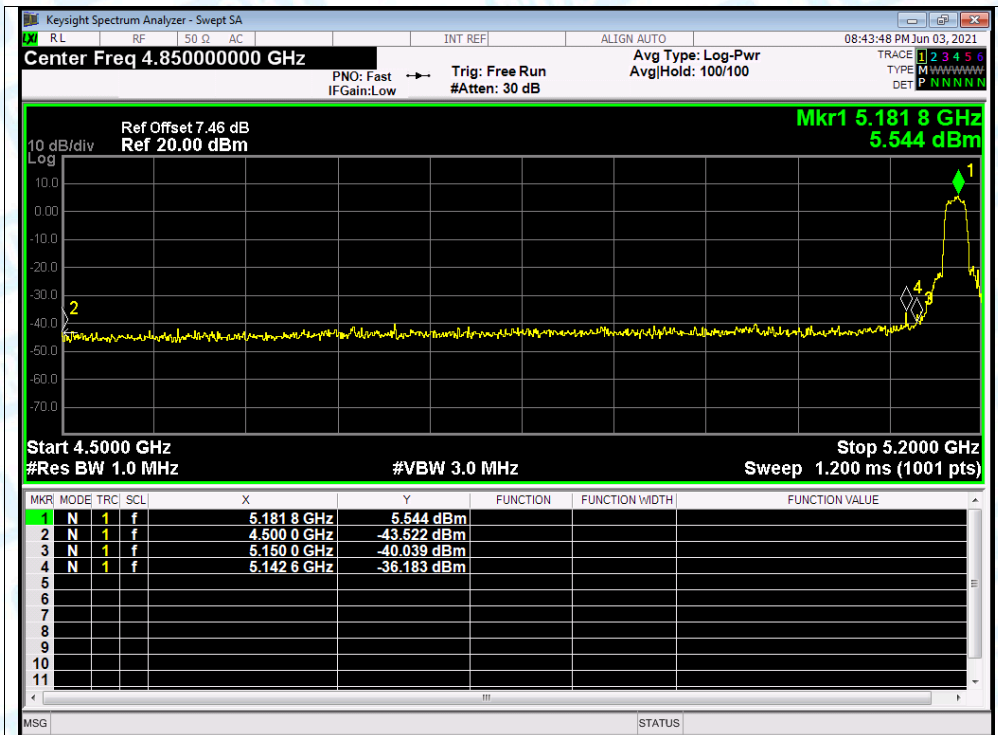

Restrict Band NVNT a 5180MHz Ant1 Average

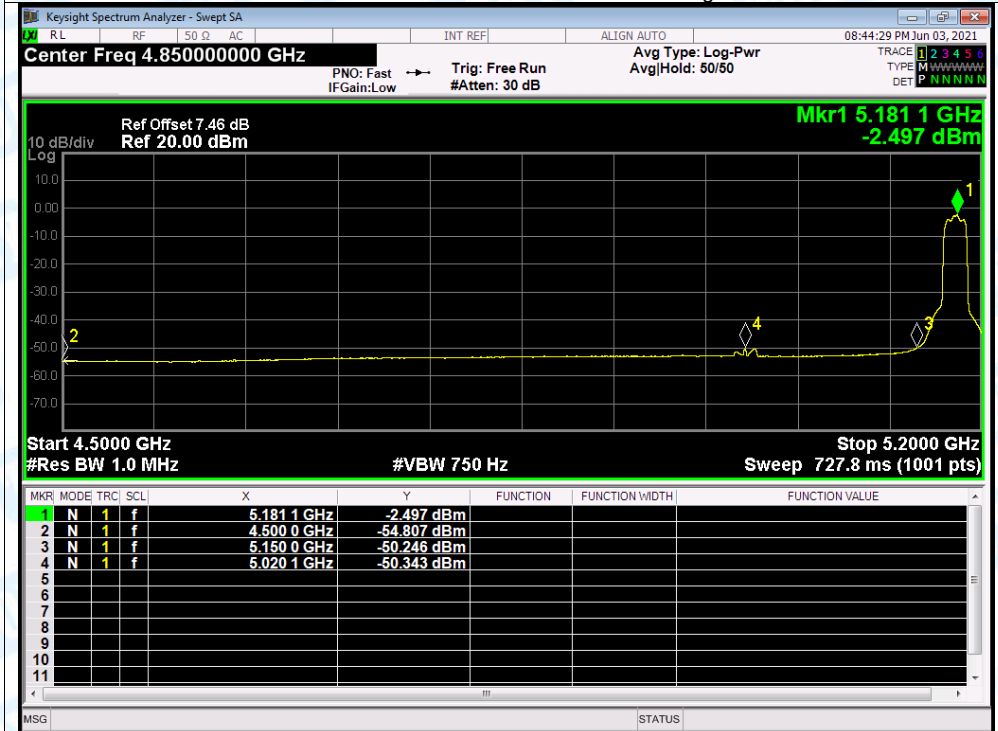

Restrict Band NVNT a 5240MHz Ant1 Peak

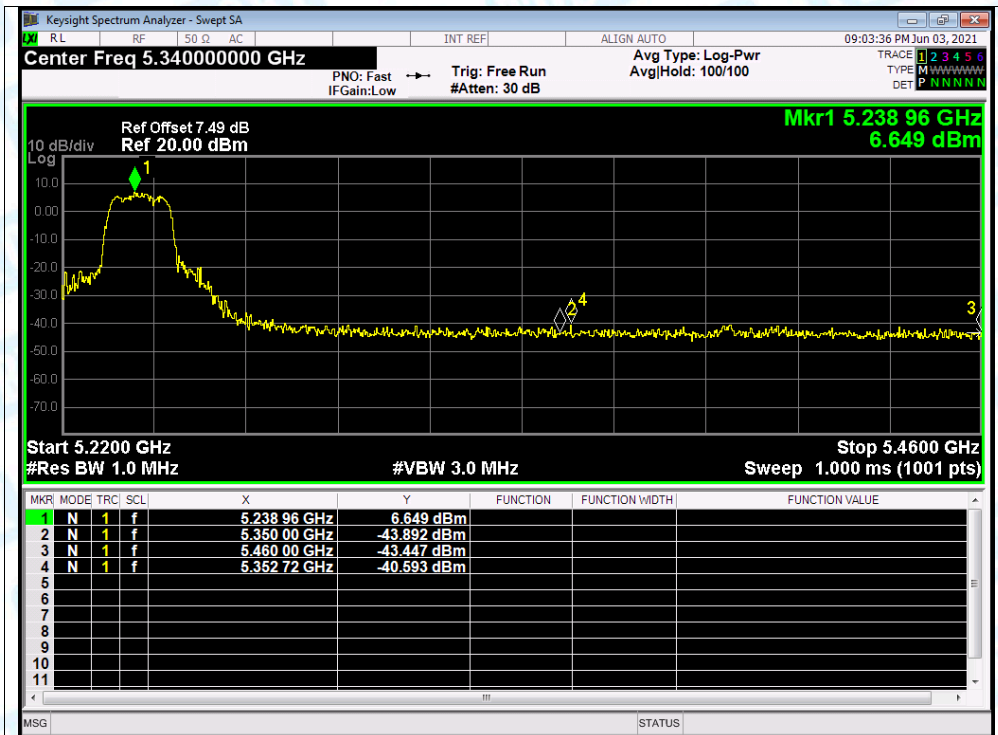

Restrict Band NVNT a 5240MHz Ant1 Average

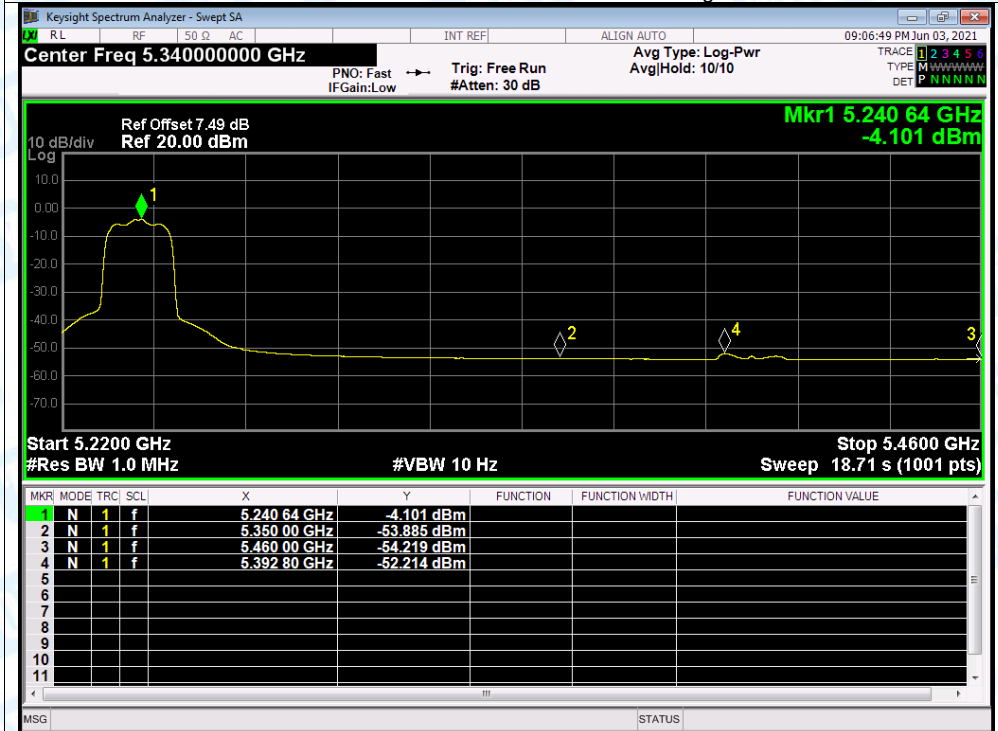

Mode	Frequency (MHz)	Antenna	Spur Freq (MHz)	Power (dBm)	Gain (dBi)	E (dBuV/m)	Detector	Limit (dBuV/m)	Verdict
a	5745	Ant1	5650	-42.83	2	-40.83	Peak	-27	Pass

a	5745	Ant1	5650	-52.35	2	-50.35	Average	-27	Pass
a	5745	Ant1	5700	-40.73	2	-38.73	Peak	10	Pass
a	5745	Ant1	5700	-51.87	2	-49.87	Average	10	Pass
a	5745	Ant1	5720	-39.34	2	-37.34	Peak	15.6	Pass
a	5745	Ant1	5720	-50.7	2	-48.7	Average	15.6	Pass
a	5745	Ant1	5725	-32.03	2	-30.03	Peak	27	Pass
a	5745	Ant1	5725	-48.66	2	-46.66	Average	27	Pass
a	5825	Ant1	5850	-41.87	2	-39.87	Peak	27	Pass
a	5825	Ant1	5850	-51.4	2	-49.4	Average	27	Pass
a	5825	Ant1	5855	-41.71	2	-39.71	Peak	15.6	Pass
a	5825	Ant1	5855	-52.02	2	-50.02	Average	15.6	Pass
a	5825	Ant1	5875	-43.02	2	-41.02	Peak	10	Pass
a	5825	Ant1	5875	-52.91	2	-50.91	Average	10	Pass
a	5825	Ant1	5925	-42.5	2	-40.5	Peak	-27	Pass
a	5825	Ant1	5925	-52.8	2	-50.8	Average	-27	Pass

Test Graphs
Restrict Band NVNT a 5745MHz Ant1 Peak

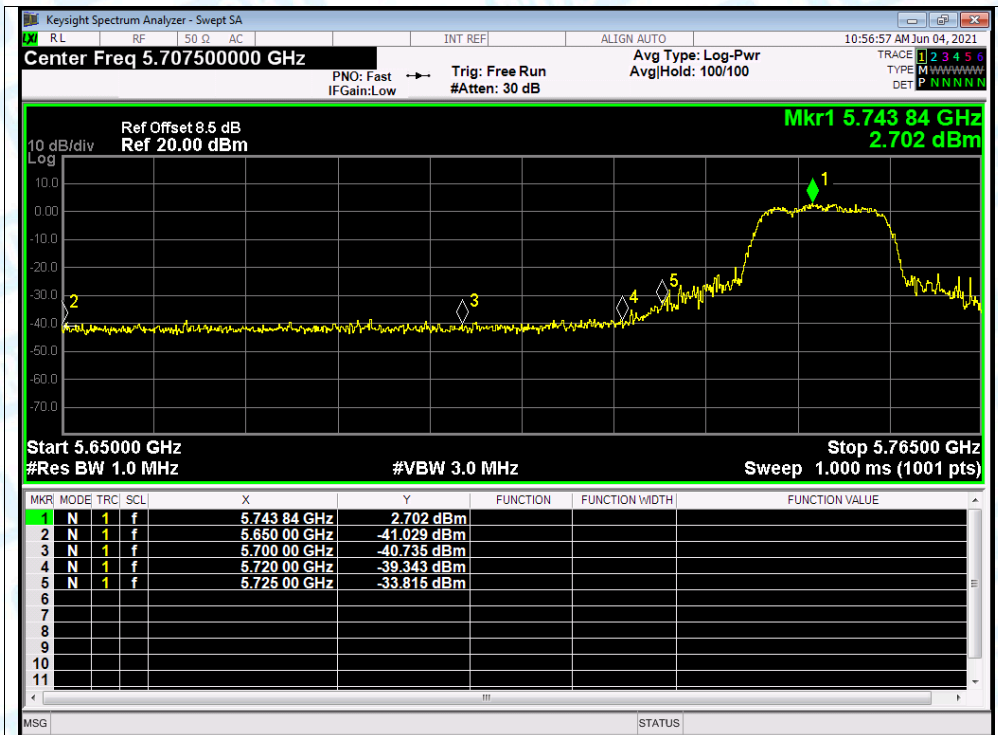

Restrict Band NVNT a 5745MHz Ant1 Average

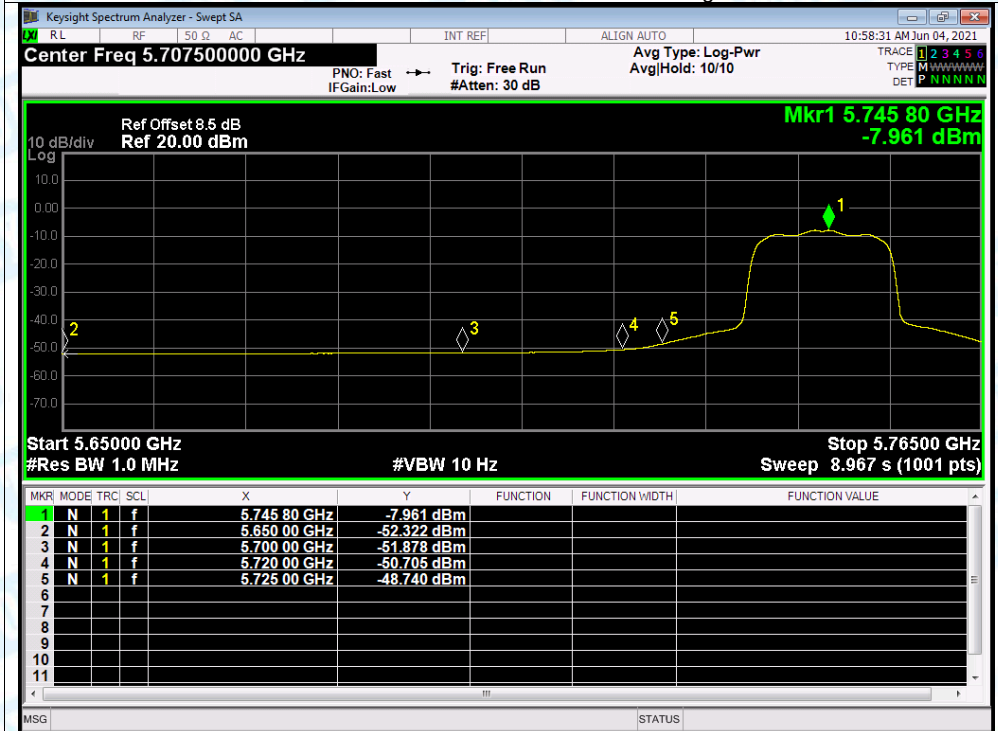

Restrict Band NVNT a 5825MHz Ant1 Peak

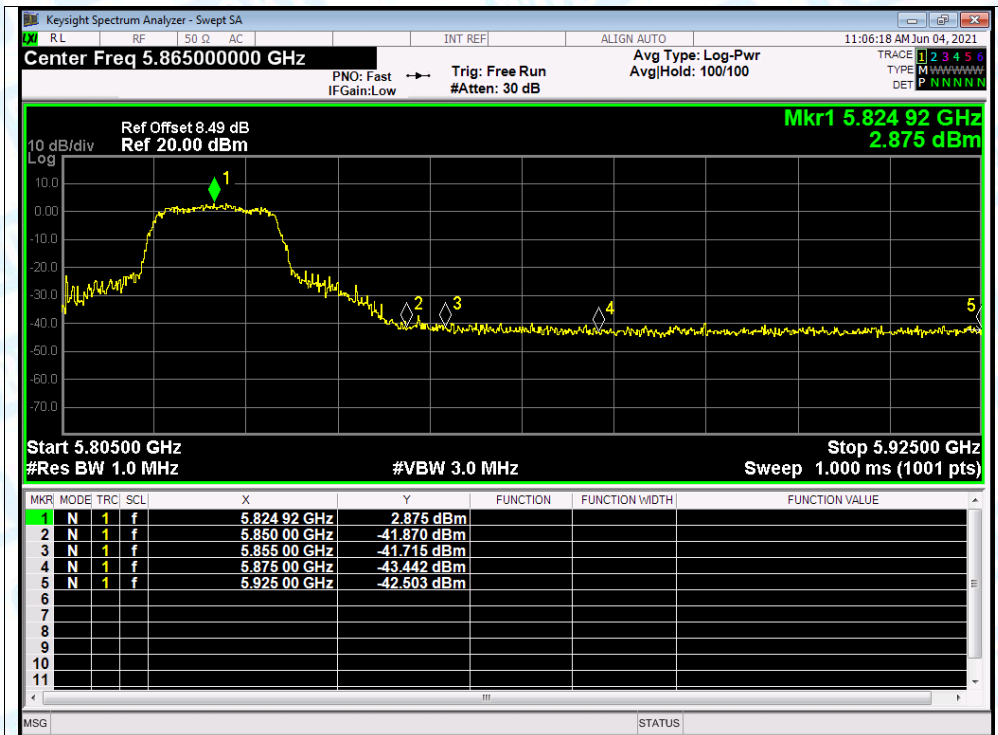

Restrict Band NVNT a 5825MHz Ant1 Average

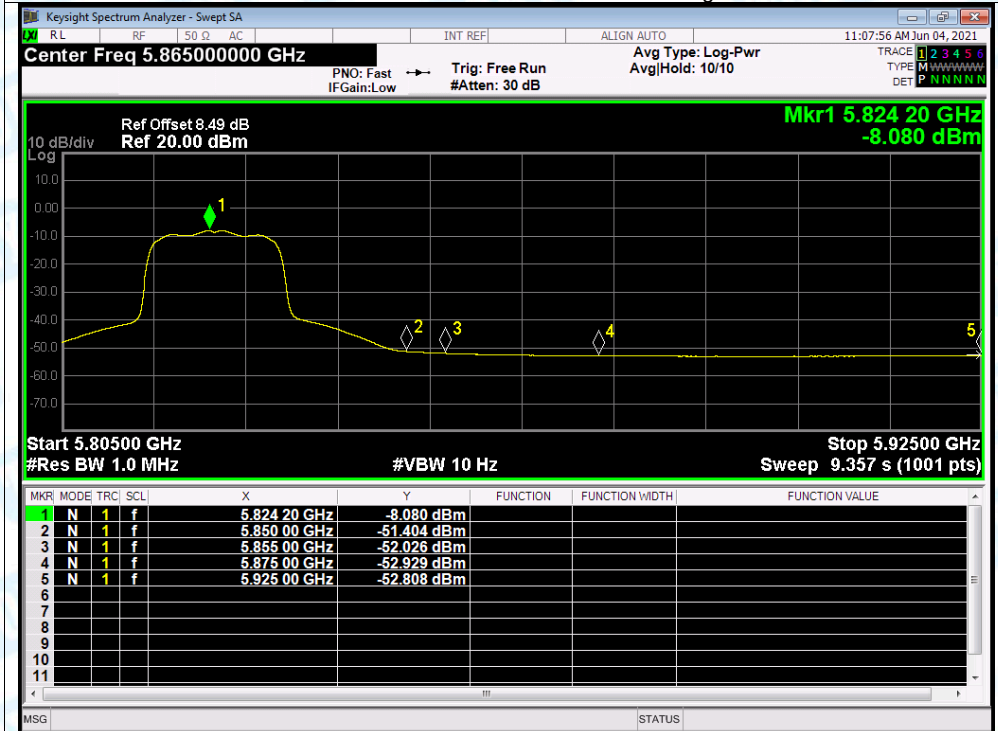

(1) Conducted Test

Temperature:	25 °C	Relative Humidity:	55%
Test Voltage:	AC 120V/60 Hz		
Test Mode:	TX 802.11a mode(U-NII-1) / 5180MHz&5240MHz		
Remark:	The EUT is programmed in continuously transmitting mode		

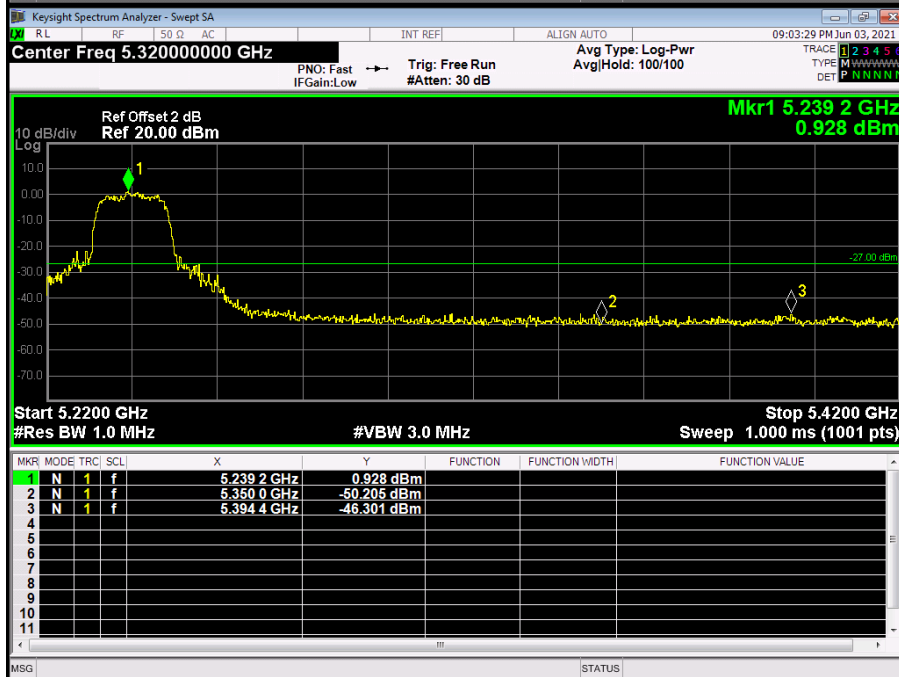
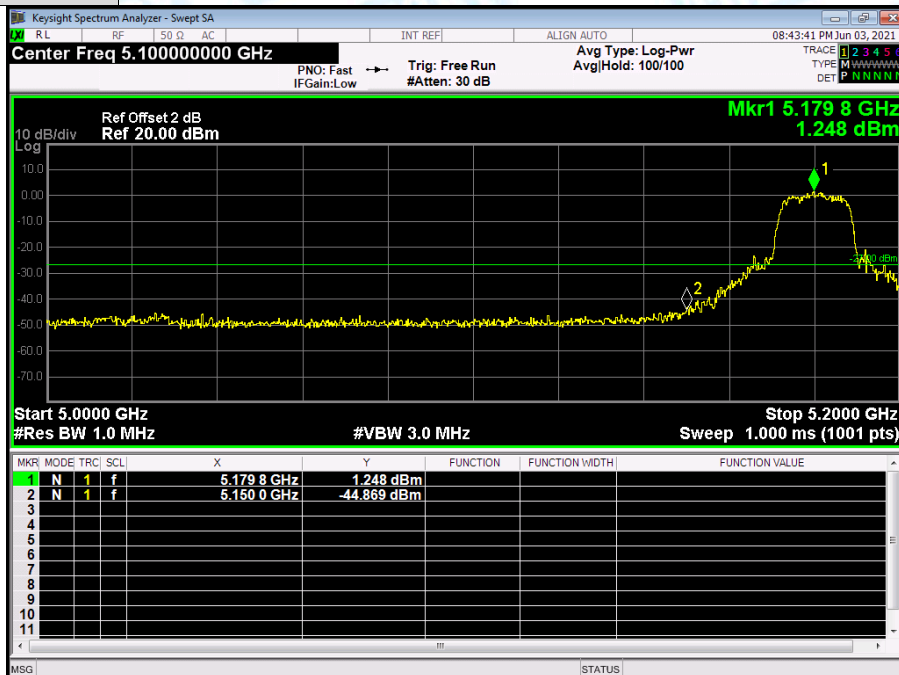

Temperature:	25 °C	Relative Humidity:	55%
Test Voltage:	AC 120V/60 Hz		
Test Mode:	TX 802.11a Mode 5745MHz/5825MHz (U-NII-3)		
Remark:	The EUT is programmed in continuously transmitting mode		

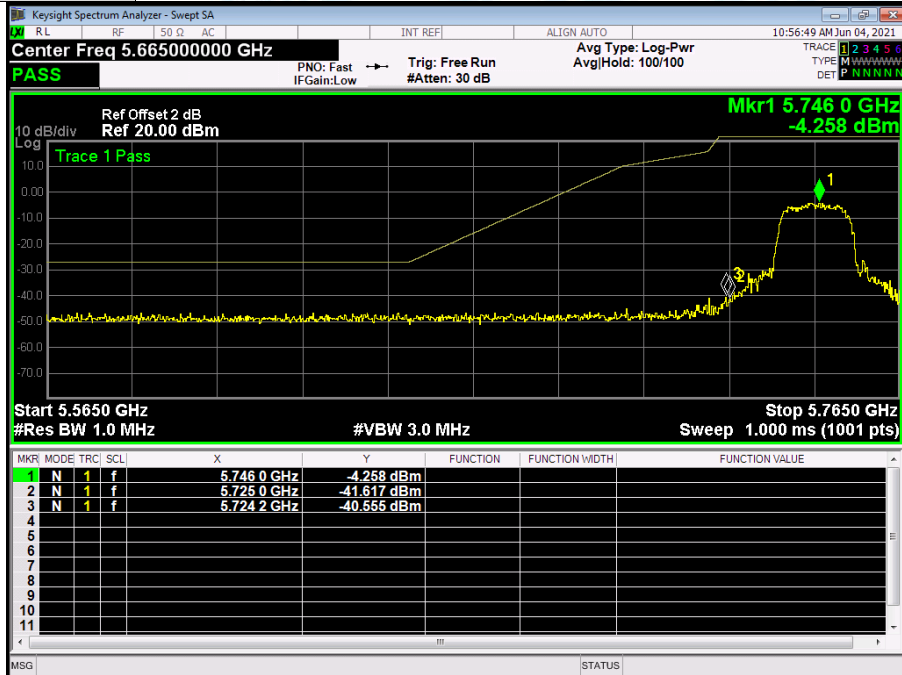

Attachment D--Bandwidth Test Data

Temperature:	25 °C	Relative Humidity:	55%												
Test Voltage:	AC 120V/60 Hz														
Test Mode:	TX 802.11a Mode (U-NII-1)														
Channel	Frequency (MHz)	26dB Bandwidth (MHz)	99% Bandwidth (MHz)												
36	5180	19.51	16.442												
40	5200	23.38	16.419												
48	5240	20.59	16.420												
802.11a Mode															
5180 MHz															
<p>Keysight Spectrum Analyzer - Occupied BW</p> <p>Center Freq: 5.180000000 GHz</p> <p>Center Freq: 5.180000000 GHz</p> <p>Radio Std: None</p> <p>Radio Device: BTS</p> <p>Ref Offset 5.46 dB</p> <p>Ref 25.46 dBm</p> <p>Center 5.18 GHz</p> <p>#Res BW 200 kHz</p> <p>#VBW 620 kHz</p> <p>Span 30 MHz</p> <p>Sweep 1.333 ms</p> <table border="1"> <tr> <td>Occupied Bandwidth</td> <td>Total Power</td> <td>12.7 dBm</td> </tr> <tr> <td>16.442 MHz</td> <td></td> <td></td> </tr> <tr> <td>Transmit Freq Error</td> <td>32.139 kHz</td> <td>% of OBW Power 99.00 %</td> </tr> <tr> <td>x dB Bandwidth</td> <td>19.51 MHz</td> <td>x dB -26.00 dB</td> </tr> </table>				Occupied Bandwidth	Total Power	12.7 dBm	16.442 MHz			Transmit Freq Error	32.139 kHz	% of OBW Power 99.00 %	x dB Bandwidth	19.51 MHz	x dB -26.00 dB
Occupied Bandwidth	Total Power	12.7 dBm													
16.442 MHz															
Transmit Freq Error	32.139 kHz	% of OBW Power 99.00 %													
x dB Bandwidth	19.51 MHz	x dB -26.00 dB													

802.11a Mode

5200 MHz

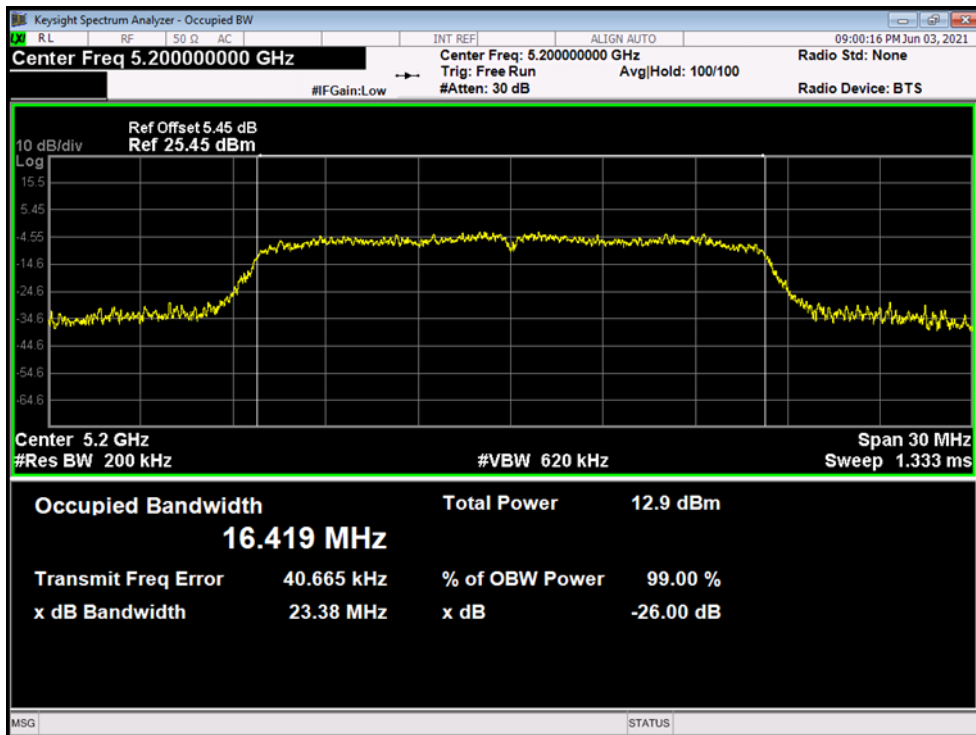

802.11a Mode

5240 MHz

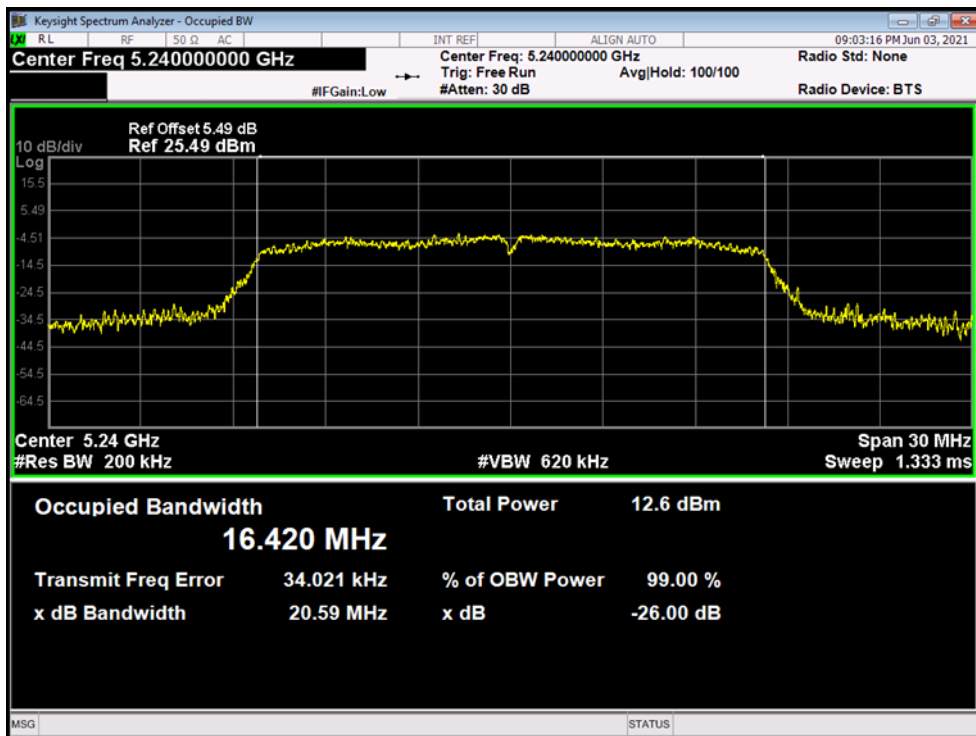

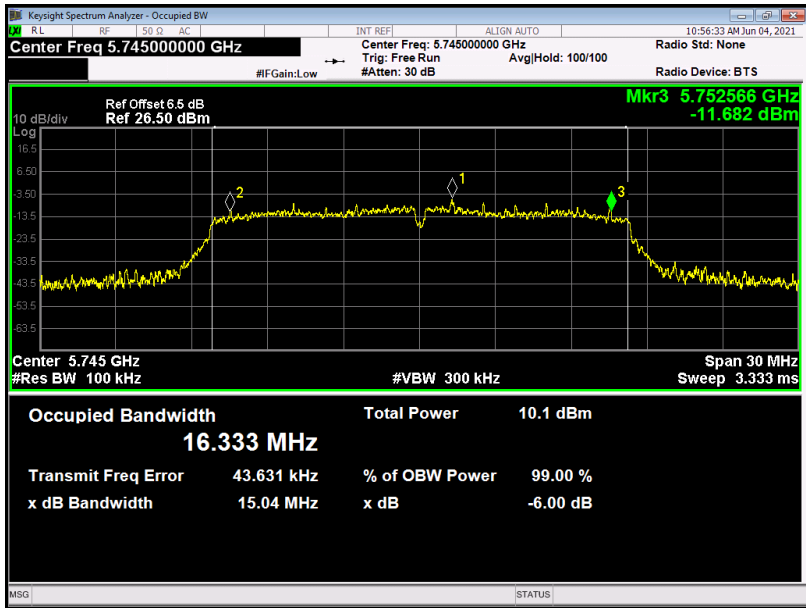
Temperature:	25 °C	Relative Humidity:	55%
Test Voltage:	AC 120V/60 Hz		
Test Mode:	TX 802.11a Mode (U-NII-3)		
Channel	Frequency (MHz)	6dB Bandwidth (MHz)	99% Bandwidth (MHz)
149	5745	15.04	16.333
157	5785	14.99	16.339
165	5825	15.34	16.364
802.11a Mode			
5745 MHz			
			

802.11a Mode

5785 MHz

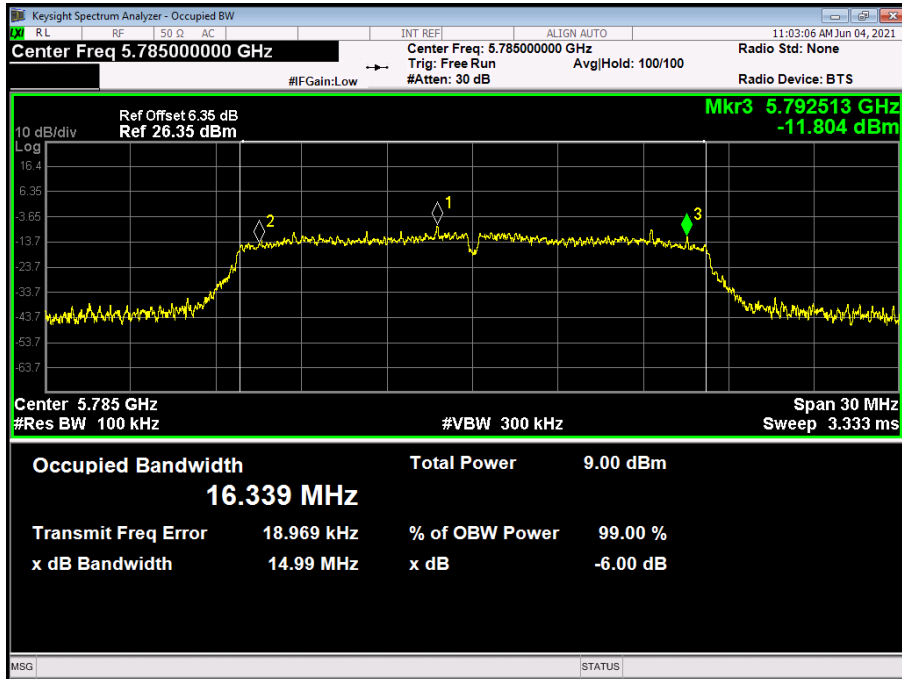

802.11a Mode

5825 MHz

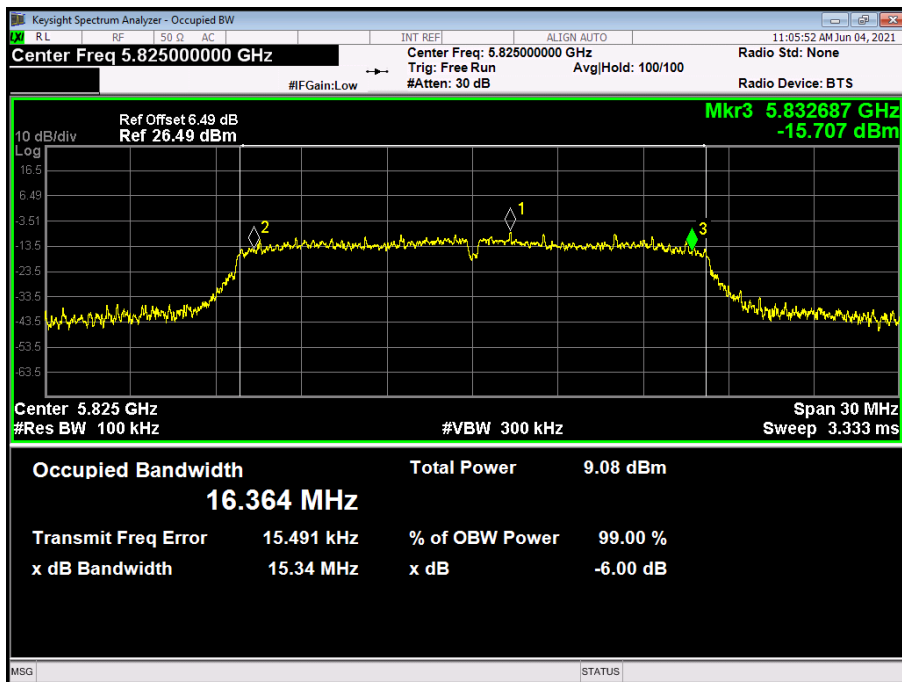

Attachment E--AVG Output Power Test Data

Temperature:	25 °C	Relative Humidity:	55%		
Test Voltage:	AC 120V/60 Hz				
U-NII-1					
Test Mode	Frequency (MHz)	Test Data			Limit (dBm)
		Conducted Power (dBm)	Duty Factor (dB)	Total Power (dBm)	
802.11a	5180	7.56	0	7.56	24
	5200	7.311	0	7.311	
	5240	7.074	0	7.074	
Result: PASS					
Remark: the Directional Gain=2.0dBi<6 dBi. So $P_{out} = P_{limit} = 24\text{dBm}$					

Temperature:	25 °C	Relative Humidity:	55%		
Test Voltage:	AC 120V/60 Hz				
U-NII-3					
Test Mode	Frequency (MHz)	Test Data			Limit (dBm)
		Conducted Power (dBm)	Duty Factor (dB)	Total Power (dBm)	
802.11a	5745	4.194	0	4.194	30
	5785	2.402	0	2.402	
	5825	3.251	0	3.251	
Result: PASS					
Remark: the Directional Gain=2.0dBi<6 dBi. So $P_{out} = P_{limit} = 30\text{dBm}$					

Test Mode		Duty cycle
U-NII-1	802.11 a	>98%
U-NII-3	802.11 a	
Please see the next plots.		

802.11 a 5200MHz U-NII-1

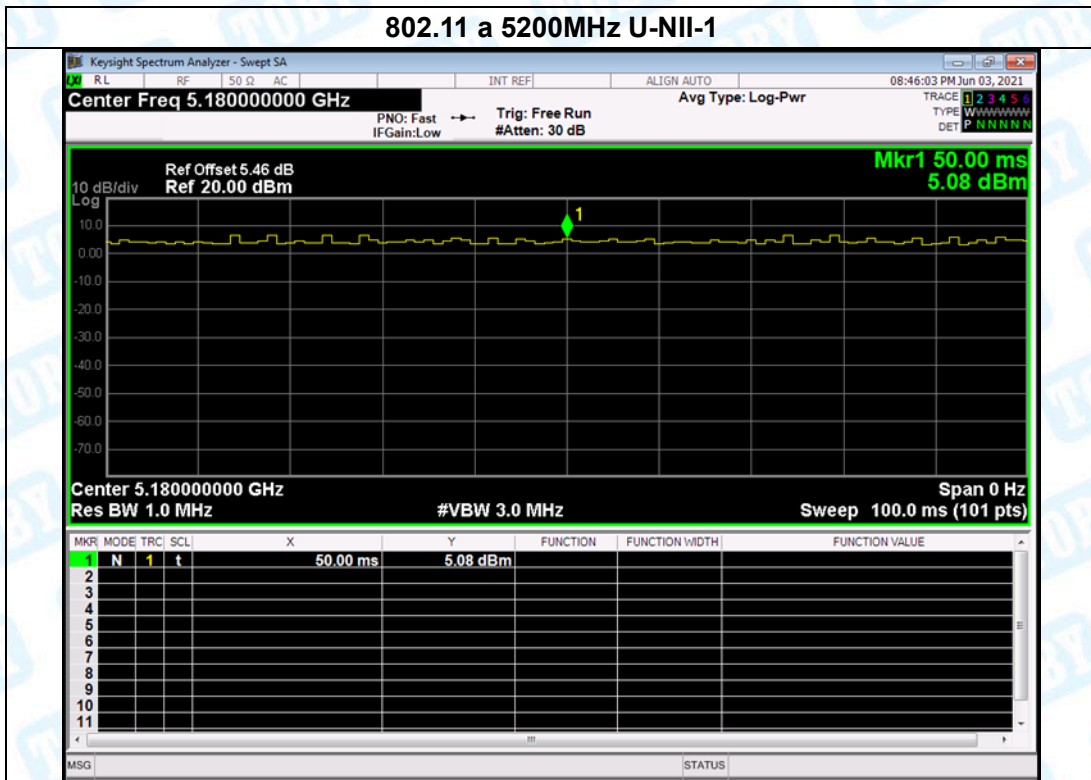

802.11 a 5785MHz U-NII-3

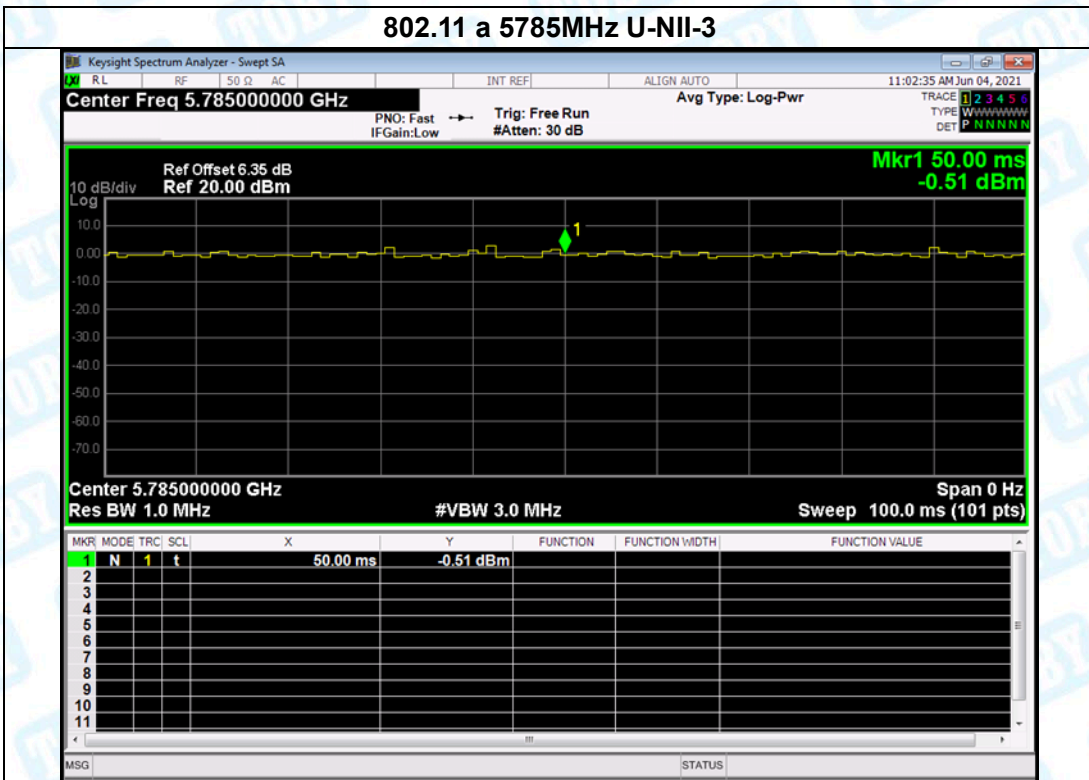

Attachment F-- Power Spectral Density Test Data

Temperature:	25 °C	Relative Humidity:	55%
Test Voltage:	AC 120V/60 Hz		
U-NII-1			
Test Mode	Frequency (MHz)	Test Data	
		Power Density (dBm/MHz)	
802.11a	5180	-0.063	
	5200	0.008	
	5240	0.012	
Limit (dBm/MHz)			
11			
Result: PASS			
Remark: the Directional Gain=2.0dBi<6 dBi. So $P_{out} = P_{limit}$			
Test plots please refer to below pages:			

802.11 a 5180 MHz

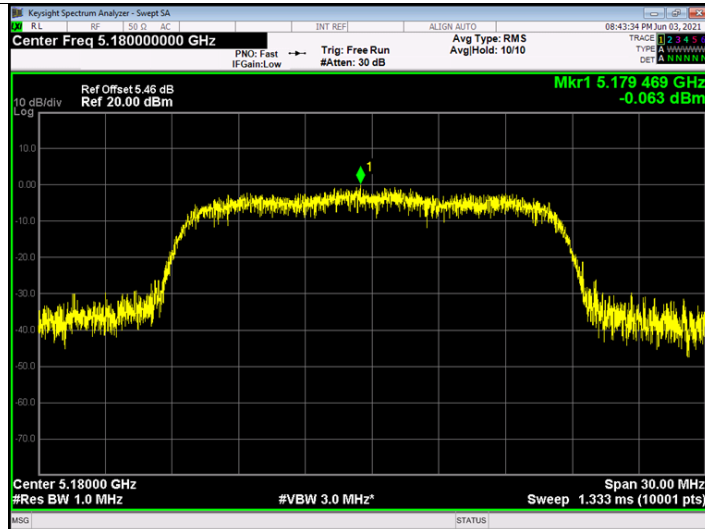

802.11 a 5200 MHz

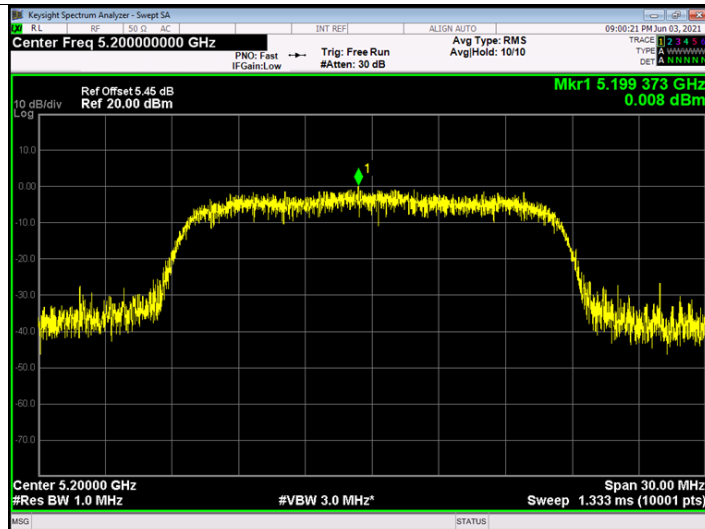

802.11 a 5240 MHz

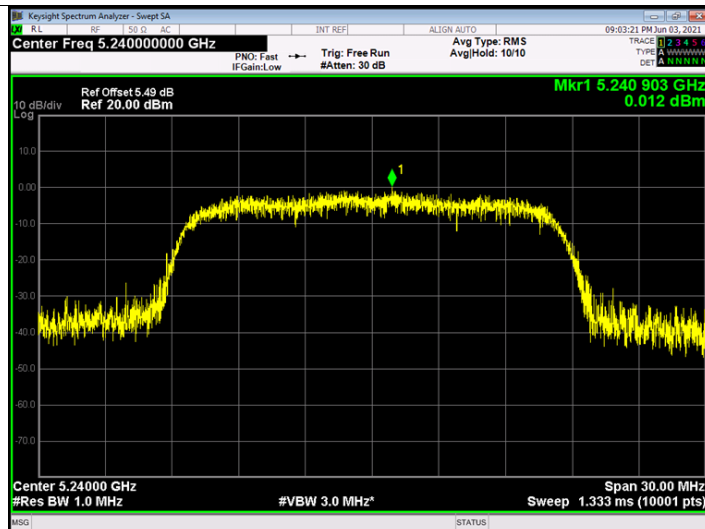

Temperature:	25 °C	Relative Humidity:	55%
Test Voltage:	AC 120V/60 Hz		
U-NII-3			
Test Mode	Frequency (MHz)	Test Data	
		Power Density (dBm/500KHz)	
802.11a	5745	-6.358	
	5785	-7.321	
	5825	-7.721	
Limit (dBm/500KHz)			
30			
Result: PASS			
Remark: the Directional Gain=2.0dBi< 6 dBi. So $P_{out} = P_{limit}$			
Test plots please refer to below pages:			

802.11 a 5745 MHz

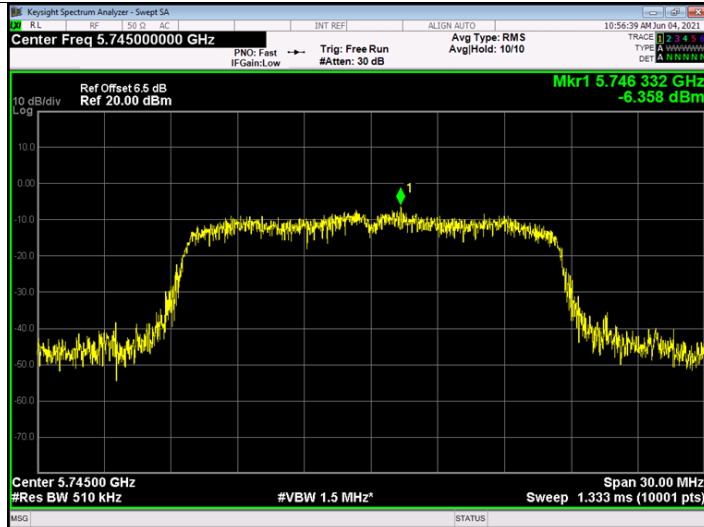

802.11 a 5785 MHz

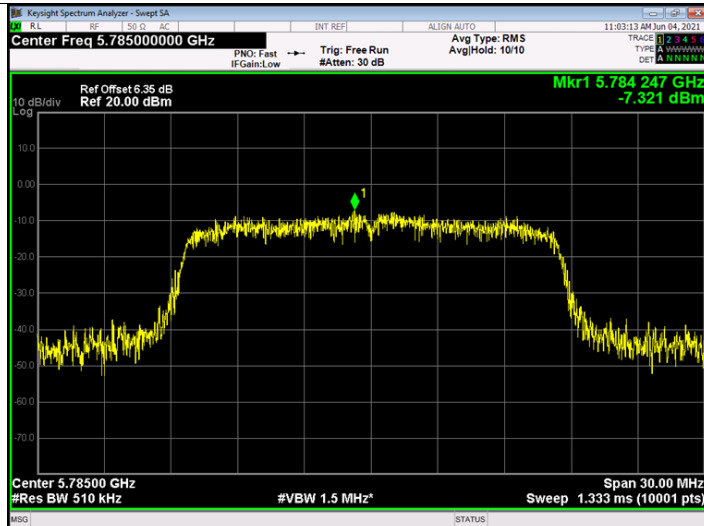

802.11 a 5825 MHz

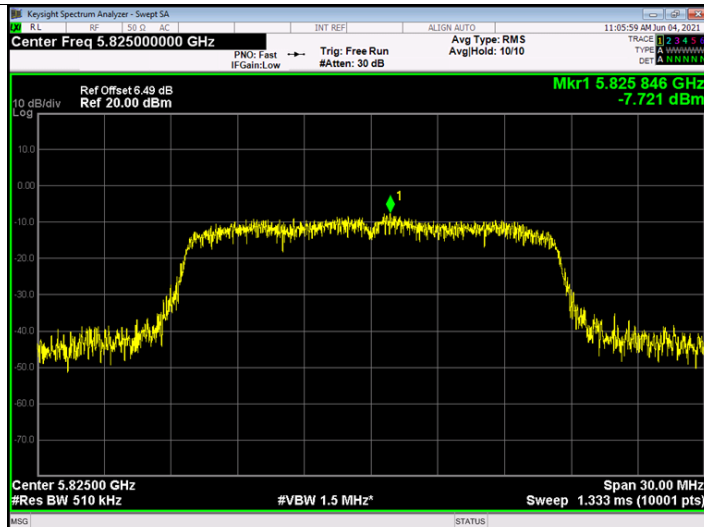

Attachment G----Frequency Stability Measurement Data

Only show the worst case 802.11 a Mode 5180MHz.

801.11a U-NII-1: 5180 MHz	
Voltage vs. Frequency Stability	
Voltage (V)	Measurement Frequency (MHz)
132	5180.0400
120	5180.0300
118	5180.0500
Limit Range (MHz)	5150-5250
Result	PASS
Temperature vs. Frequency Stability	
Temperature (°C)	Measurement Frequency (MHz)
0	5180.0500
10	5180.0300
20	5180.0200
30	5180.0300
40	5180.0500
50	5180.0400
Limit Range (MHz)	5150-5250
Result	PASS

Only show the worst case 802.11 a Mode 5745MHz.

801.11a U-NII-3: 5745 MHz	
Voltage vs. Frequency Stability	
Voltage (V)	Measurement Frequency (MHz)
132	5745.0300
120	5745.0400
118	5744.0500
Limit Range (MHz)	5725-5850
Result	PASS
Temperature vs. Frequency Stability	
Temperature (°C)	Measurement Frequency (MHz)
0	5745.0200
10	5745.0600
20	5745.0300
30	5745.0400
40	5745.0700
50	5745.0600
Limit Range (MHz)	5725-5850
Result	PASS

-----END OF REPORT-----