

FCC Radio Test Report

FCC ID: 2AAH9-3700

Original Grant

Report No. : TB-FCC180399
Applicant : Navori Inc.
Equipment Under Test (EUT)
EUT Name : StiX
Model No. : 3700
Series Model No. : N/A
Brand Name : Navori
Sample ID : TBBJ-20210325-18_01-1#&20210325-18_01-2#
Receipt Date : 2021-05-14
Test Date : 2021-05-14 to 2021-06-28
Issue Date : 2021-06-28
Standards : FCC Part 15, Subpart C 15.247
Test Method : ANSI C63.10: 2013
Conclusions : **PASS**

In the configuration tested, the EUT complied with the standards specified above,
The EUT technically complies with the FCC requirements

Test/Witness Engineer : *Camille Li*

Camille Li

Engineer Supervisor : *Ivan Su*

Ivan Su

Engineer Manager : *Ray Lai*

Ray Lai



This report details the results of the testing carried out on one sample. The results contained in this test report do not relate to other samples of the same product. The manufacturer should ensure that all products in series production are in conformity with the product sample detailed in the report.

Contents

| | |
|---|-----------|
| CONTENTS | 2 |
| 1. GENERAL INFORMATION ABOUT EUT | 6 |
| 1.1 Client Information..... | 6 |
| 1.2 General Description of EUT (Equipment Under Test)..... | 6 |
| 1.3 Block Diagram Showing the Configuration of System Tested..... | 8 |
| 1.4 Description of Support Units..... | 8 |
| 1.5 Description of Test Mode..... | 9 |
| 1.6 Description of Test Software Setting..... | 10 |
| 1.7 Measurement Uncertainty..... | 10 |
| 1.8 Test Facility..... | 11 |
| 2. TEST SUMMARY | 12 |
| 3. TEST SOFTWARE | 12 |
| 4. TEST EQUIPMENT | 13 |
| 5. CONDUCTED EMISSION TEST | 14 |
| 5.1 Test Standard and Limit..... | 14 |
| 5.2 Test Setup..... | 14 |
| 5.3 Test Procedure..... | 15 |
| 5.4 Deviation From Test Standard..... | 15 |
| 5.5 EUT Operating Mode..... | 15 |
| 5.6 Test Data..... | 15 |
| 6. RADIATED EMISSION TEST | 16 |
| 6.1 Test Standard and Limit..... | 16 |
| 6.2 Test Setup..... | 17 |
| 6.3 Test Procedure..... | 18 |
| 6.4 Deviation From Test Standard..... | 18 |
| 6.4 EUT Operating Condition..... | 18 |
| 6.5 Test Data..... | 18 |
| 7. RESTRICTED BANDS REQUIREMENT | 19 |
| 7.1 Test Standard and Limit..... | 19 |
| 7.2 Test Setup..... | 19 |
| 7.3 Test Procedure..... | 20 |
| 7.4 Deviation From Test Standard..... | 21 |
| 7.5 EUT Operating Condition..... | 21 |
| 7.6 Test Data..... | 21 |
| 8. CONDUCTED SPURIOUS EMISSIONS AND BAND EDGES TEST | 22 |
| 8.1.1 Test Standard..... | 22 |
| 8.1.2 Test Limit..... | 22 |
| 8.7.3. Test Procedures..... | 22 |
| 8.7.4. Test Setup Layout..... | 22 |
| 8.7.5. EUT Operation during Test..... | 23 |

| | |
|--|-----------|
| 8.7.6. Test Data | 23 |
| 9. NUMBER OF HOPPING CHANNEL..... | 24 |
| 8.1 Test Standard and Limit..... | 24 |
| 8.2 Test Setup..... | 24 |
| 8.3 Test Procedure..... | 24 |
| 8.4 Deviation From Test Standard..... | 24 |
| 8.5 EUT Operating Condition | 24 |
| 8.6 Test Data..... | 24 |
| 10. AVERAGE TIME OF OCCUPANCY..... | 25 |
| 9.1 Test Standard and Limit..... | 25 |
| 9.2 Test Setup..... | 25 |
| 9.3 Test Procedure..... | 25 |
| 9.4 EUT Operating Condition | 25 |
| 9.4 Deviation From Test Standard..... | 26 |
| 9.5 EUT Operating Condition | 26 |
| 9.6 Test Data..... | 26 |
| 11. CHANNEL SEPARATION AND BANDWIDTH TEST | 27 |
| 10.1 Test Standard and Limit | 27 |
| 10.2 Test Setup..... | 27 |
| 10.3 Test Procedure..... | 27 |
| 10.4 Deviation From Test Standard..... | 28 |
| 10.5 EUT Operating Condition | 28 |
| 10.6 Test Data..... | 28 |
| 12. PEAK OUTPUT POWER TEST..... | 29 |
| 11.1 Test Standard and Limit | 29 |
| 11.2 Test Setup..... | 29 |
| 11.3 Test Procedure..... | 29 |
| 11.4 Deviation From Test Standard..... | 29 |
| 11.5 EUT Operating Condition | 29 |
| 11.6 Test Data..... | 29 |
| 13. ANTENNA REQUIREMENT..... | 30 |
| 12.1 Standard Requirement..... | 30 |
| 12.2 Deviation From Test Standard..... | 30 |
| 12.3 Antenna Connected Construction | 30 |
| 12.4 Result..... | 30 |
| ATTACHMENT A-- CONDUCTED EMISSION TEST DATA | 31 |
| ATTACHMENT B-- RADIATED EMISSION TEST DATA | 33 |
| ATTACHMENT C-- EMISSIONS IN RESTRICTED BANDS TEST DATA | 44 |
| ATTACHMENT D-- CONDUCTED SPURIOUS EMISSIONS AND BAND EDGES TEST | 51 |
| ATTACHMENT E-- NUMBER OF HOPPING CHANNEL TEST DATA | 66 |
| ATTACHMENT F-- AVERAGE TIME OF OCCUPANCY TEST DATA | 68 |
| ATTACHMENT G-- CHANNEL SEPARATION AND BANDWIDTH TEST DATA..... | 74 |

ATTACHMENT H-- PEAK OUTPUT POWER TEST DATA..... 83

1. General Information about EUT

1.1 Client Information

| | | |
|---------------------|---|--|
| Applicant | : | Navori Inc. |
| Address | : | 1000 rue Sherbrooke st W,Suite 710, Montreal, QC, Canada H3A 3G4 |
| Manufacturer | : | Shenzhen MicoRose Technology Co., Ltd. |
| Address | : | 8B2A, Daqing Building, southeast of the intersection of Shennan Road and Guangshen Expressway, Futian District, Shenzhen,China |

1.2 General Description of EUT (Equipment Under Test)

| | | |
|-------------------------------|------------------------|--|
| EUT Name | : | StiX |
| Model(s) | : | 3700 |
| Product Description | Operation Frequency: | Bluetooth V4.0(BT): 2402~2480 MHz |
| | Number of Channel: | Bluetooth: 79 Channels <small>See Note 2</small> |
| | Max Peak Output Power: | Bluetooth: 5.831dBm (8DPSK) |
| | Antenna Gain: | 2.0dBi RP-SMA Antenna |
| | Modulation Type: | GFSK $\pi/4$ -DQPSK 8DPSK |
| Power Supply | : | For Adapter: Input: 100-240V~ Output:5V $\overline{\text{---}}$, 2.5A |
| Software Version | : | android 9.0 |
| Hardware Version | : | V1 |
| Connecting I/O Port(S) | : | Please refer to the User's Manual |

Note:

- (1) This Test Report is FCC Part 15.247 for Bluetooth, the test procedure follows the FCC KDB 558074 D01 DTS Means Guidance v05.

(2) For a more detailed features description, please refer to the manufacturer’s specifications or the User’s Manual.Channel List:

| Bluetooth Channel List | | | | | |
|------------------------|-----------------|---------|-----------------|---------|-----------------|
| Channel | Frequency (MHz) | Channel | Frequency (MHz) | Channel | Frequency (MHz) |
| 00 | 2402 | 27 | 2429 | 54 | 2456 |
| 01 | 2403 | 28 | 2430 | 55 | 2457 |
| 02 | 2404 | 29 | 2431 | 56 | 2458 |
| 03 | 2405 | 30 | 2432 | 57 | 2459 |
| 04 | 2406 | 31 | 2433 | 58 | 2460 |
| 05 | 2407 | 32 | 2434 | 59 | 2461 |
| 06 | 2408 | 33 | 2435 | 60 | 2462 |
| 07 | 2409 | 34 | 2436 | 61 | 2463 |
| 08 | 2410 | 35 | 2437 | 62 | 2464 |
| 09 | 2411 | 36 | 2438 | 63 | 2465 |
| 10 | 2412 | 37 | 2439 | 64 | 2466 |
| 11 | 2413 | 38 | 2440 | 65 | 2467 |
| 12 | 2414 | 39 | 2441 | 66 | 2468 |
| 13 | 2415 | 40 | 2442 | 67 | 2469 |
| 14 | 2416 | 41 | 2443 | 68 | 2470 |
| 15 | 2417 | 42 | 2444 | 69 | 2471 |
| 16 | 2418 | 43 | 2445 | 70 | 2472 |
| 17 | 2419 | 44 | 2446 | 71 | 2473 |
| 18 | 2420 | 45 | 2447 | 72 | 2474 |
| 19 | 2421 | 46 | 2448 | 73 | 2475 |
| 20 | 2422 | 47 | 2449 | 74 | 2476 |
| 21 | 2423 | 48 | 2450 | 75 | 2477 |
| 22 | 2424 | 49 | 2451 | 76 | 2478 |
| 23 | 2425 | 50 | 2452 | 77 | 2479 |
| 24 | 2426 | 51 | 2453 | 78 | 2480 |
| 25 | 2427 | 52 | 2454 | | |
| 26 | 2428 | 53 | 2455 | | |

(3) The Antenna information about the equipment is provided by the applicant.

1.3 Block Diagram Showing the Configuration of System Tested

Charging + TX Mode

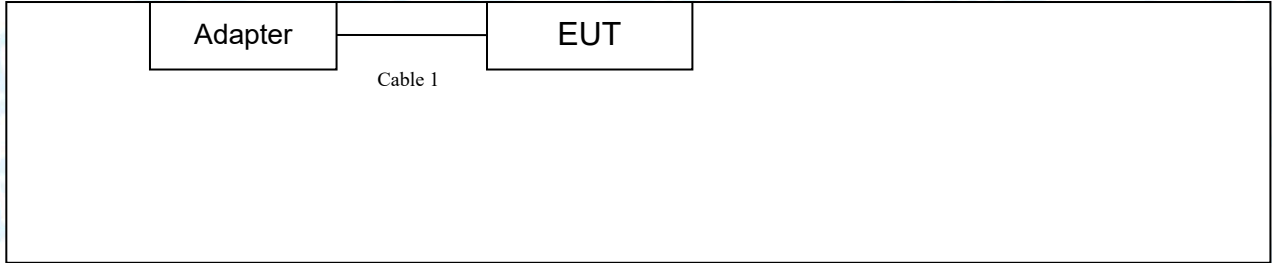

1.4 Description of Support Units

| Equipment Information | | | | |
|-----------------------|---------------|--------------|--------------------------|----------|
| Name | Model | FCC ID/VOC | Manufacturer | Used “√” |
| DELL | U2720QM | ---- | Dell (China) Co., Ltd | √ |
| Cable Information | | | | |
| Number | Shielded Type | Ferrite Core | Length | Note |
| ---- | ----- | ---- | ----- | ---- |

1.5 Description of Test Mode

To investigate the maximum EMI emission characteristics generates from EUT, the test system was pre-scanning tested base on the consideration of following EUT operation mode or test configuration mode which possible have effect on EMI emission level. Each of these EUT operation mode(s) or test configuration mode(s) mentioned follow was evaluated respectively.

| For Conducted Test | |
|---|--|
| Final Test Mode | Description |
| Mode 1 | Charging + TX Mode Channel 00 |
| For Radiated Test | |
| Final Test Mode | Description |
| Mode 1 | TX GFSK Mode Channel 00 |
| Mode 2 | TX Mode (GFSK) Channel 00/39/78 |
| Mode 3 | TX Mode ($\pi/4$ -DQPSK) Channel 00/39/78 |
| Mode 4 | TX Mode (8DPSK) Channel 00/39/78 |
| Mode 5 | Hopping Mode (GFSK) |
| Mode 6 | Hopping Mode ($\pi/4$ -DQPSK) |
| Mode 7 | Hopping Mode (8DPSK) |
| <p>Note : (1)The adapter and antenna gain provided by the applicant, the verified for the RF conduction test provided by TOBY test lab.</p> <p>(2) All test with left and right earphone, and only show the worst case(left earphone)</p> | |

Note:

- (1) For all test, we have verified the construction and function in typical operation. And all the test modes were carried out with the EUT in transmitting operation in maximum power with all kinds of data rate. We have pretested all the test modes above.
According to ANSI C63.10 standards, the measurements are performed at the highest, middle, lowest available channels, and the worst case data rate as follows:
 TX Mode: GFSK (1 Mbps)
 TX Mode: $\pi/4$ -DQPSK (2 Mbps)
 TX Mode: 8DPSK (3 Mbps)
- (2) The EUT is considered a portable unit; it was pre-tested on the positioned of each 3 axis, X-plane, Y-plane and Z-plane. The worst case was found positioned on X-plane as the normal use. Therefore only the test data of this X-plane was used for radiated emission measurement test.

1.6 Description of Test Software Setting

During testing channel power controlling software provided by the customer was used to control the operating channel as well as the output power level. The RF output power selection is for the setting of RF output power expected by the customer and is going to be fixed on the firmware of the final end product power parameters of Bluetooth mode.

| Test Software Version | FCC_assist | | |
|-----------------------|------------|---------|----------|
| | 2402 MHz | 2441MHz | 2480 MHz |
| Frequency | 2402 MHz | 2441MHz | 2480 MHz |
| GFSK | DEF | DEF | DEF |
| $\pi/4$ -DQPSK | DEF | DEF | DEF |
| 8DPSK | DEF | DEF | DEF |

1.7 Measurement Uncertainty

The reported uncertainty of measurement $y \pm U$, where expanded uncertainty U is based on a standard uncertainty multiplied by a coverage factor of $k=2$, providing a level of confidence of approximately 95 %.

| Test Item | Parameters | Expanded Uncertainty (U_{Lab}) |
|--------------------|---|------------------------------------|
| Conducted Emission | Level Accuracy: 9kHz~150kHz 150kHz to 30MHz | ± 3.50 dB ± 3.10 dB |
| Radiated Emission | Level Accuracy: 9kHz to 30 MHz | ± 4.60 dB |
| Radiated Emission | Level Accuracy: 30MHz to 1000 MHz | ± 4.50 dB |
| Radiated Emission | Level Accuracy: Above 1000MHz | ± 4.20 dB |

1.8 Test Facility

The testing report were performed by the Shenzhen Toby Technology Co., Ltd., in their facilities located at 1/F., Building 6, Rundongsheng Industrial Zone, Longzhu, Xixiang, Bao'an, Shenzhen, Guangdong, China. At the time of testing, the following bodies accredited the Laboratory:

CNAS (L5813)

The Laboratory has been accredited by CNAS to ISO/IEC 17025: 2017 General Requirements for the Competence of Testing and Calibration Laboratories for the competence in the field of testing. And the Registration No.: CNAS L5813.

A2LA Certificate No.: 4750.01

The laboratory has been accredited by American Association for Laboratory Accreditation(A2LA) to ISO/IEC 17025: 2017 General Requirements for the Competence of Testing and Calibration Laboratories for the technical competence in the field of Electrical Testing. And the A2LA Certificate No.: 4750.01. FCC Accredited Test Site Number: 854351.Designation Number:CN1223

IC Registration No.: (11950A)

The Laboratory has been registered by Certification and Engineering Bureau of Industry Canada for radio equipment testing. The site registration: Site# 11950A.

2. Test Summary

| FCC Part 15 Subpart C(15.247)/ RSS 247 Issue 2 | | | | | |
|--|--------------------|---|--|----------|--------|
| Standard Section | | Test Item | Test Sample(s) | Judgment | Remark |
| FCC | IC | | | | |
| 15.203 | RSS-GEN 6.8 | Antenna Requirement | TBBJ-20210325-18_01-1# | PASS | N/A |
| 15.207 | RSS-GEN 8.8 | Conducted Emission | TBBJ-20210325-18_01-2# | PASS | N/A |
| 15.205 | RSS-Gen 8.10 | Restricted Bands | TBBJ-20210325-18_01-1# | PASS | N/A |
| 15.247(a)(1) | RSS 247 5.1 (b) | Hopping Channel Separation | TBBJ-20210325-18_01-1# | PASS | N/A |
| 15.247(a)(1) | RSS 247 5.1 (d) | Dwell Time | TBBJ-20210325-18_01-1# | PASS | N/A |
| 15.247(b)(1) | RSS 247 5.4 (b) | Peak Output Power | TBBJ-20210325-18_01-1# | PASS | N/A |
| 15.247(a)(1) | RSS 247 5.1 (d) | Number of Hopping Frequency | TBBJ-20210325-18_01-1# | PASS | N/A |
| 15.247(d) | RSS 247 5.5 | Conducted Spurious Emissions&Band edge | TBBJ-20210325-18_01-1# | PASS | N/A |
| 15.247(c)& 15.209 | RSS 247 5.5 | Radiated Spurious Emission | TBBJ-20210325-18_01-1# TBBJ-20210325-18_01-2# | PASS | N/A |
| 15.247(a) | RSS 247 5.1 (a) | 99% Occupied Bandwidth & 20dB Bandwidth | TBBJ-20210325-18_01-1# | PASS | N/A |

Note: N/A is an abbreviation for Not Applicable.

3. Test Software

| Test Item | Test Software | Manufacturer | Version No. |
|--------------------------|---------------|--------------|-------------|
| Conducted Emission | EZ-EMC | EZ | CDI-03A2 |
| Radiation Emission | EZ-EMC | EZ | FA-03A2RE |
| RF Conducted Measurement | MTS-8310 | MWRFtest | V2.0.0.0 |

4. Test Equipment

| Conducted Emission Test | | | | | |
|----------------------------|----------------------------------|-------------------|---------------|---------------|---------------|
| Equipment | Manufacturer | Model No. | Serial No. | Last Cal. | Cal. Due Date |
| EMI Test Receiver | Rohde & Schwarz | ESCI | 100321 | Jul. 06, 2020 | Jul. 05, 2021 |
| RF Switching Unit | Compliance Direction Systems Inc | RSU-A4 | 34403 | Jul. 06, 2020 | Jul. 05, 2021 |
| AMN | SCHWARZBECK | NNBL 8226-2 | 8226-2/164 | Jul. 06, 2020 | Jul. 05, 2021 |
| LISN | Rohde & Schwarz | ENV216 | 101131 | Jul. 06, 2020 | Jul. 05, 2021 |
| Radiation Emission Test | | | | | |
| Equipment | Manufacturer | Model No. | Serial No. | Last Cal. | Cal. Due Date |
| Spectrum Analyzer | Agilent | E4407B | MY45106456 | Jul. 06, 2020 | Jul. 05, 2021 |
| EMI Test Receiver | Rohde & Schwarz | ESPI | 100010/007 | Jul. 06, 2020 | Jul. 05, 2021 |
| Spectrum Analyzer | Rohde & Schwarz | FSV40-N | 102197 | Jul. 06, 2020 | Jul. 05, 2021 |
| Bilog Antenna | ETS-LINDGREN | 3142E | 00117537 | Mar.01, 2020 | Feb. 28, 2022 |
| Horn Antenna | ETS-LINDGREN | 3117 | 00143207 | Mar.01, 2020 | Feb. 28, 2022 |
| Horn Antenna | ETS-LINDGREN | BBHA 9170 | BBHA9170582 | Mar.01, 2020 | Feb. 28, 2022 |
| Loop Antenna | SCHWARZBECK | FMZB 1519 B | 1519B-059 | Jul. 07, 2020 | Jul. 06, 2021 |
| Pre-amplifier | Sonoma | 310N | 185903 | Feb.25, 2021 | Feb. 24, 2022 |
| Pre-amplifier | HP | 8449B | 3008A00849 | Feb.25, 2021 | Feb. 24, 2022 |
| Pre-amplifier | SKET | LNPA_1840G-50 | SK201904032 | Feb.25, 2021 | Feb. 24, 2022 |
| Cable | HUBER+SUHNER | 100 | SUCOFLEX | Feb.25, 2021 | Feb. 24, 2022 |
| Positioning Controller | ETS-LINDGREN | 2090 | N/A | N/A | N/A |
| Antenna Conducted Emission | | | | | |
| Equipment | Manufacturer | Model No. | Serial No. | Last Cal. | Cal. Due Date |
| Spectrum Analyzer | Agilent | E4407B | MY45106456 | Jul. 06, 2020 | Jul. 05, 2021 |
| Spectrum Analyzer | Rohde & Schwarz | ESPI | 100010/007 | Jul. 06, 2020 | Jul. 05, 2021 |
| MXA Signal Analyzer | Agilent | N9020A | MY49100060 | Sep. 11, 2020 | Sep. 10, 2021 |
| Vector Signal Generator | Agilent | N5182A | MY50141294 | Sep. 11, 2020 | Sep. 10, 2021 |
| Analog Signal Generator | Agilent | N5181A | MY50141953 | Sep. 11, 2020 | Sep. 10, 2021 |
| RF Power Sensor | DARE!! Instruments | RadiPowerRPR3006W | 17100015SNO26 | Sep. 11, 2020 | Sep. 10, 2021 |
| | DARE!! Instruments | RadiPowerRPR3006W | 17100015SNO29 | Sep. 11, 2020 | Sep. 10, 2021 |
| | DARE!! Instruments | RadiPowerRPR3006W | 17100015SNO31 | Sep. 11, 2020 | Sep. 10, 2021 |
| | DARE!! Instruments | RadiPowerRPR3006W | 17100015SNO33 | Sep. 11, 2020 | Sep. 10, 2021 |

5. Conducted Emission Test

5.1 Test Standard and Limit

5.1.1 Test Standard

FCC Part 15.207

5.1.2 Test Limit

Conducted Emission Test Limit

| Frequency | Maximum RF Line Voltage (dB μ V) | |
|---------------|--------------------------------------|---------------|
| | Quasi-peak Level | Average Level |
| 150kHz~500kHz | 66 ~ 56 * | 56 ~ 46 * |
| 500kHz~5MHz | 56 | 46 |
| 5MHz~30MHz | 60 | 50 |

Notes:

(1) *Decreasing linearly with logarithm of the frequency.

(2) The lower limit shall apply at the transition frequencies.

(3) The limit decrease in line with the logarithm of the frequency in the range of 0.15 to 0.50MHz.

5.2 Test Setup

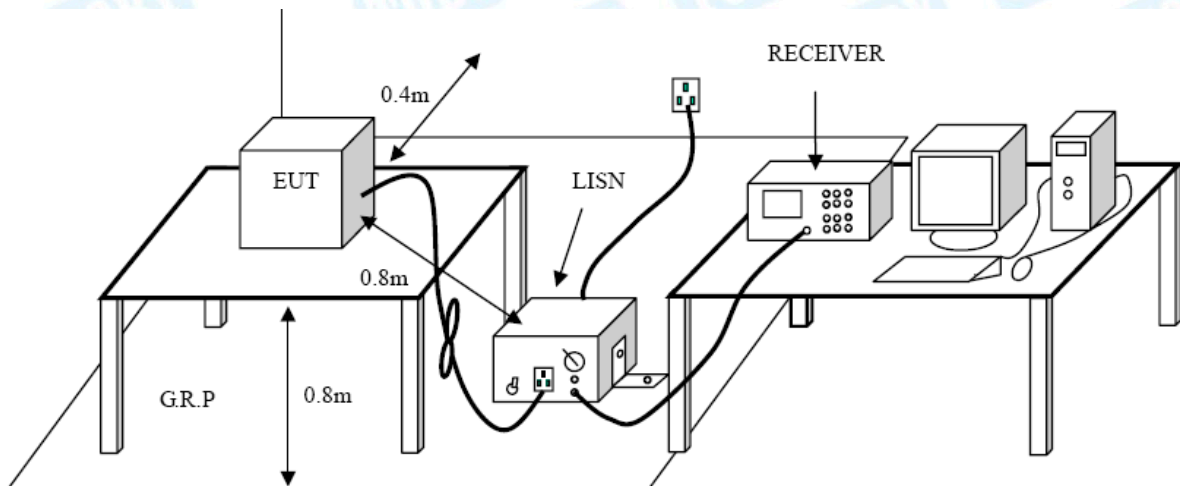

5.3 Test Procedure

The EUT was placed 0.8 meters from the horizontal ground plane with EUT being connected to the power mains through a line impedance stabilization network (LISN). All other support equipments powered from additional LISN(s). The LISN provide 50 Ohm/50uH of coupling impedance for the measuring instrument.

Interconnecting cables that hang closer than 40 cm to the ground plane shall be folded back and forth in the center forming a bundle 30 to 40 cm long.

I/O cables that are not connected to a peripheral shall be bundled in the center. The end of the cable may be terminated, if required, using the correct terminating impedance. The overall length shall not exceed 1 m.

LISN at least 80 cm from nearest part of EUT chassis

The bandwidth of EMI test receiver is set at 9kHz, and the test frequency band is from 0.15MHz to 30MHz.

5.4 Deviation From Test Standard

No deviation

5.5 EUT Operating Mode

Please refer to the description of test mode.

5.6 Test Data

Please refer to the Attachment A.

6. Radiated Emission Test

6.1 Test Standard and Limit

6.1.1 Test Standard
FCC Part 15.209

6.1.2 Test Limit

Radiated Emission Limit (9 kHz~1000MHz)

| Frequency (MHz) | Field Strength (microvolt/meter) | Measurement Distance (meters) |
|-----------------|----------------------------------|-------------------------------|
| 0.009~0.490 | 2400/F(KHz) | 300 |
| 0.490~1.705 | 24000/F(KHz) | 30 |
| 1.705~30.0 | 30 | 30 |
| 30~88 | 100 | 3 |
| 88~216 | 150 | 3 |
| 216~960 | 200 | 3 |
| Above 960 | 500 | 3 |

Radiated Emission Limit (Above 1000MHz)

| Frequency (MHz) | Distance of 3m (dBuV/m) | |
|-----------------|-------------------------|---------|
| | Peak | Average |
| Above 1000 | 74 | 54 |

Note:

- (1) The tighter limit applies at the band edges.
- (2) Emission Level (dBuV/m)=20log Emission Level (uV/m)

6.2 Test Setup

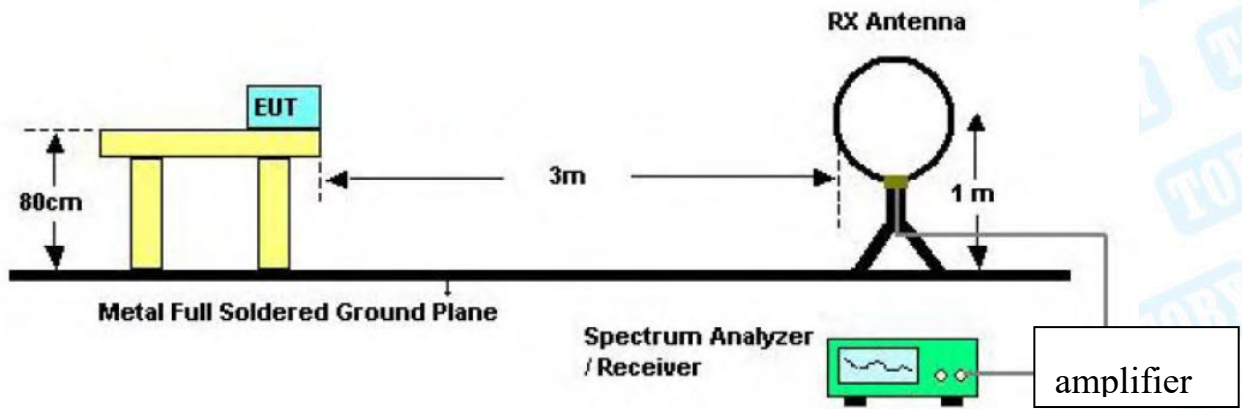

Below 30MHz Test Setup

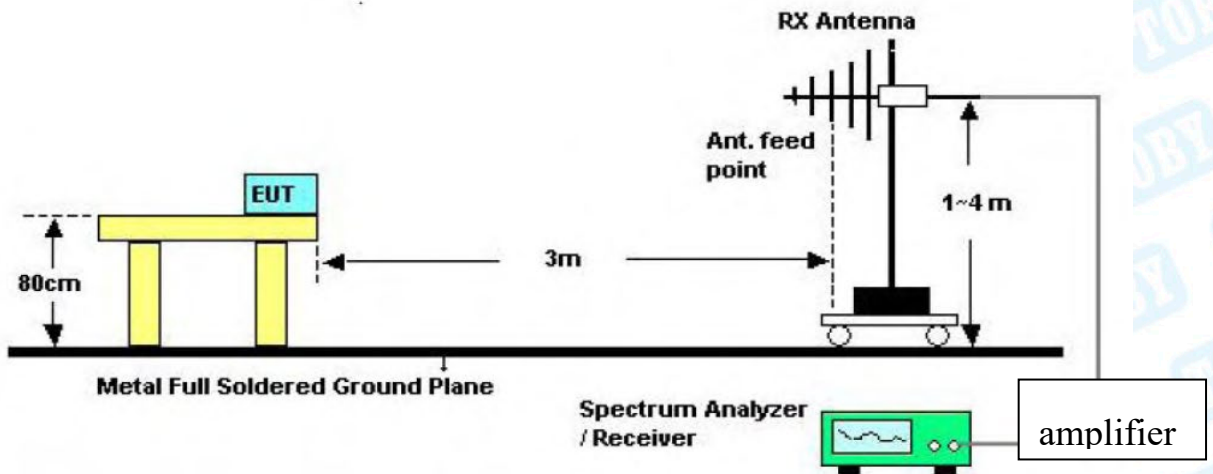

Below 1000MHz Test Setup

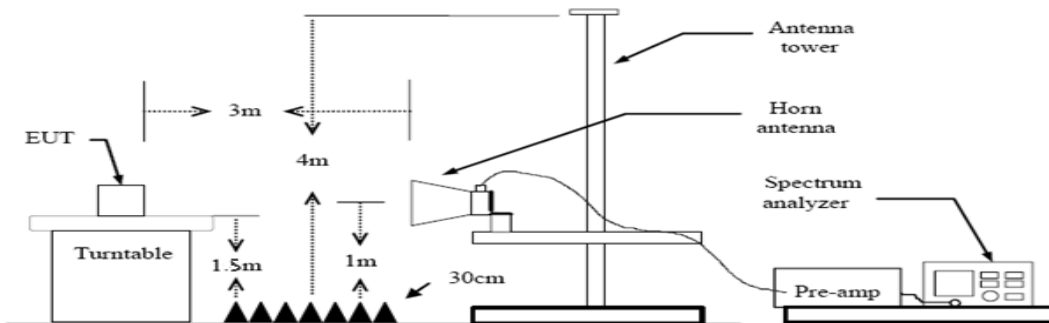

Above 1GHz Test Setup

6.3 Test Procedure

- (1) The measuring distance of 3m shall be used for measurements at frequency up to 1GHz and above 1 GHz. The EUT was placed on a rotating 0.8m high above ground, the table was rotated 360 degrees to determine the position of the highest radiation.
- (2) Measurements at frequency above 1GHz. The EUT was placed on a rotating 1.5m high above the ground. RF absorbers covered the ground plane with a minimum area of 3.0m by 3.0m between the EUT and measurement receiver antenna. The RF absorber shall not exceed 30cm in high above the conducting floor. The table was rotated 360 degrees to determine the position of the highest radiation.
- (3) The Test antenna shall vary between 1m and 4m, Both Horizontal and Vertical antenna are set to make measurement.
- (4) The initial step in collecting conducted emission data is a spectrum analyzer peak detector mode pre-scanning the measurement frequency range. Significant peaks are then marked and then Quasi Peak detector mode re-measured.
- (5) If the Peak Mode measured value compliance with and lower than Quasi Peak Mode Limit Bellow 1 GHz, the EUT shall be deemed to meet QP Limits and then no additional QP Mode measurement performed. But the Peak Value and average value both need to comply with applicable limit above 1 GHz.
- (6) Testing frequency range below 1GHz the measuring instrument use VBW=120 kHz with Quasi-peak detection.
- (7) Testing frequency range above 1GHz the measuring instrument use RBW=1 MHz and VBW=3 MHz with Peak Detector for Peak Values, and use RBW=1 MHz and VBW=10 Hz with Peak Detector for Average Values.
- (8) For the actual test configuration, please see the test setup photo.

6.4 Deviation From Test Standard

No deviation

6.4 EUT Operating Condition

The Equipment Under Test was set to Continual Transmitting in maximum power in TX mode.

6.5 Test Data

Remark: During testing above 1GHz the measuring instrument use RBW=1 MHz and VBW=3 MHz with Peak Detector for Peak Values, and use RBW=1 MHz and VBW=10 Hz with Peak Detector for Average Values.

Please refer to the Attachment B.

7. Restricted Bands Requirement

7.1 Test Standard and Limit

7.1.1 Test Standard

FCC Part 15.209

FCC Part 15.205

7.1.2 Test Limit

| Restricted Frequency Band (MHz) | Distance of 3m (dBuV/m) | |
|---------------------------------|-------------------------|---------|
| | Peak | Average |
| 2310 ~2390 | 74 | 54 |
| 2483.5 ~2500 | 74 | 54 |

Note: All restriction bands have been tested, only the worst case is reported.

7.2 Test Setup

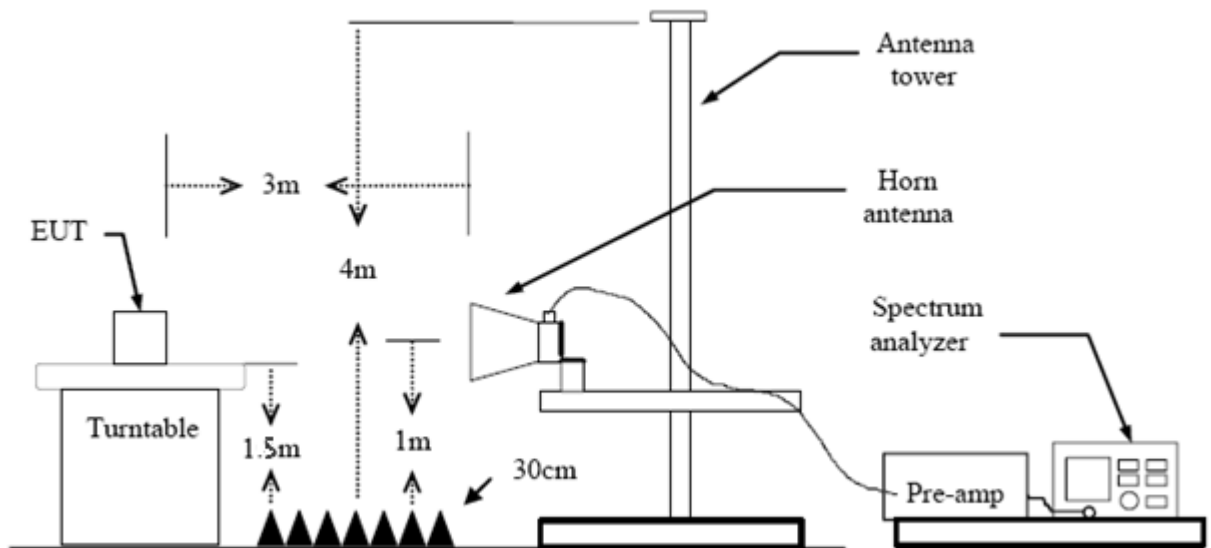

7.3 Test Procedure

---Radiated measurement

- Measurements at frequency above 1GHz. The EUT was placed on a rotating 1.5m high above the ground. RF absorbers covered the ground plane with a minimum area of 3.0m by 3.0m between the EUT and measurement receiver antenna. The RF absorber shall not exceed 30cm in high above the conducting floor. The table was rotated 360 degrees to determine the position of the highest radiation.
- The Test antenna shall vary between 1m and 4m, Both Horizontal and Vertical antenna are set to make measurement.
- The initial step in collecting conducted emission data is a spectrum analyzer peak detector mode pre-scanning the measurement frequency range. Significant peaks are then marked and then Quasi Peak detector mode re-measured.
- The Peak Value and average value both need to comply with applicable limit above 1 GHz.
- Testing frequency range above 1GHz the measuring instrument use RBW=1 MHz and VBW=3 MHz with Peak Detector for Peak Values, and use RBW=1 MHz and VBW=10 Hz with Peak Detector for Average Values.
- For the actual test configuration, please see the test setup photo.

--- Conducted measurement

- a) Measure the conducted output power (in dBm) using the detector specified by the appropriate regulatory agency (see 11.12.2.3 through 11.12.2.5 for guidance regarding measurement procedures for determining quasi-peak, peak, and average conducted output power, respectively).
- b) Add the maximum transmit antenna gain (in dBi) to the measured output power level to determine the EIRP (see 11.12.2.6 for guidance on determining the applicable antenna gain).
- c) Add the appropriate maximum ground reflection factor to the EIRP (6 dB for frequencies ≤ 30 MHz; 4.7 dB for frequencies between 30 MHz and 1000 MHz, inclusive; and 0 dB for frequencies > 1000 MHz).
- d) For MIMO devices, measure the power of each chain and sum the EIRP of all chains in linear terms (i.e., watts and mW).
- e) Convert the resultant EIRP to an equivalent electric field strength using the following relationship:
$$E = \text{EIRP} - 20 \log d + 104.8$$
where
E is the electric field strength in dBuV/m
EIRP is the equivalent isotropically radiated power in dBm
d is the specified measurement distance in m
- f) Compare the resultant electric field strength level with the applicable regulatory limit.
- g) Perform the radiated spurious emission test.

7.4 Deviation From Test Standard

No deviation

7.5 EUT Operating Condition

The Equipment Under Test was set to Continual Transmitting in maximum power.

7.6 Test Data

Remark: During testing above 1GHz the measuring instrument use RBW=1 MHz and VBW=3 MHz with Peak Detector for Peak Values, and use RBW=1 MHz and VBW=10 Hz with Peak Detector for Average Values.

All restriction bands have been tested, only the worst case is reported.

Please refer to the Attachment C.

8. Conducted Spurious Emissions and Band Edges Test

8.1.1 Test Standard

According to RSS 247§ 5.5: In any 100 kHz bandwidth outside the frequency band in which the spread spectrum or digitally modulated intentional radiator is operating, the radio frequency power that is produced by the intentional radiator shall be at least 20 dB below that in the 100 kHz bandwidth within the band that contains the highest level of the desired power, based on either an RF conducted or a radiated measurement. Attenuation below the general limits specified in Section 15.209(a) is not required. In addition, radiated emissions which fall in the restricted bands, as defined in Section 15.205(a), must also comply with the radiated emission limits specified in Section 15.209(a) (see Section 15.205(c)).

8.1.2 Test Limit

Please refer to equipment list in this report. The following table is the setting of the spectrum analyzer.

| Spectrum Parameter | Setting |
|---|---------------|
| Detector | Peak |
| Attenuation | Auto |
| RB / VB (Emission in restricted band) | 100KHz/300KHz |
| RB / VB (Emission in non-restricted band) | 100KHz/300KHz |

8.7.3. Test Procedures

The transmitter output is connected to a spectrum analyzer. The resolution bandwidth is set to 100 kHz. The video bandwidth is set to 300 kHz

The spectrum from 9 kHz to 26.5GHz is investigated with the transmitter set to the lowest, middle, and highest channels.

8.7.4. Test Setup Layout

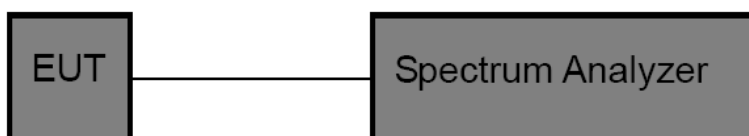

8.7.5. EUT Operation during Test

The EUT was programmed to be in continuously transmitting mode.

8.7.6. Test Data

Please refer to the Attachment D.

Remark:

- 1). Test results including cable loss;
- 2). “---“means that the fundamental frequency not for 15.209 limits requirement.
- 3). Not recorded emission from 9 KHz to 30 MHz as emission level at least 20dBc lower than emission limit.

9. Number of Hopping Channel

8.1 Test Standard and Limit

- 8.1.1 Test Standard
FCC Part 15.247 (a)(1)
- 8.1.2 Test Limit

| Section | Test Item | Limit |
|---------|---------------------------|-------|
| 15.247 | Number of Hopping Channel | >15 |

8.2 Test Setup

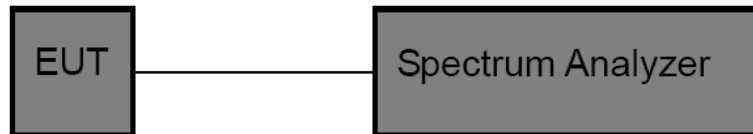

8.3 Test Procedure

- (1) The EUT was directly connected to the spectrum analyzer and antenna output port as show in the block diagram above.
- (2) Spectrum Setting: RBW=100 KHz, VBW=100 KHz, Sweep time= Auto.

8.4 Deviation From Test Standard

No deviation

8.5 EUT Operating Condition

The EUT was set to the Hopping Mode by the Customer.

8.6 Test Data

Please refer to the Attachment E.

10. Average Time of Occupancy

9.1 Test Standard and Limit

9.1.1 Test Standard
FCC Part 15.247 (a)(1)

9.1.2 Test Limit

| Section | Test Item | Limit |
|--------------|---------------------------|---------|
| 15.247(a)(1) | Average Time of Occupancy | 0.4 sec |

9.2 Test Setup

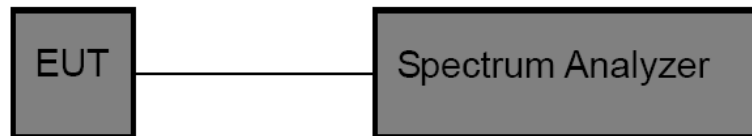

9.3 Test Procedure

- (1) The EUT was directly connected to the spectrum analyzer and antenna output port as show in the block diagram above.
- (2) Spectrum Setting: RBW=1MHz, VBW=1MHz.
- (3) Use video trigger with the trigger level set to enable triggering only on full pulses.
- (4) Sweep Time is more than once pulse time.
- (5) Set the centre frequency on any frequency would be measure and set the frequency span to zero.
- (6) Measure the maximum time duration of one single pulse.
- (7) Set the EUT for packet transmitting.
- (8) Measure the maximum time duration of one single pulse.

9.4 EUT Operating Condition

The average time of occupancy on any channel within the Period can be calculated with formulas:

$$\{Total\ of\ Dwell\} = \{Pulse\ Time\} * (1600 / X) / \{Number\ of\ Hopping\ Frequency\} * \{Period\}$$

$$\{Period\} = 0.4s * \{Number\ of\ Hopping\ Frequency\}$$

Note: X=2 or 4 or 6 (1DH1=2, 1DH3=4, 1DH5=6. 2DH1=2, 2DH3=4, 2DH5=6. 3DH1=2, 3DH3=4, 3DH5=6)

The lowest, middle and highest channels are selected to perform testing to record the dwell time of each occupation measured in this channel, which is called Pulse Time here.

9.4 Deviation From Test Standard

No deviation

9.5 EUT Operating Condition

The EUT was set to the Hopping Mode by the Customer.

9.6 Test Data

Please refer to the Attachment F.

11. Channel Separation and Bandwidth Test

10.1 Test Standard and Limit

10.1.1 Test Standard

FCC Part 15.247

10.1.2 Test Limit

| Test Item | Limit | Frequency Range(MHz) |
|--------------------|--|----------------------|
| Bandwidth | ≤ 1 MHz (20dB bandwidth) | 2400~2483.5 |
| Channel Separation | >25 KHz or $>$ two-thirds of the 20 dB bandwidth Which is greater | 2400~2483.5 |

10.2 Test Setup

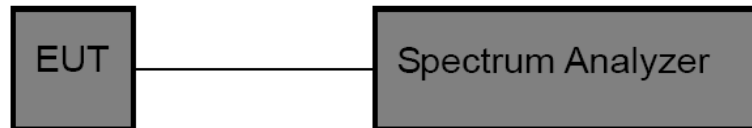

10.3 Test Procedure

- (1) The EUT was directly connected to the spectrum analyzer and antenna output port as show in the block diagram above.
- (2) Spectrum Setting:
Channel Separation: RBW=100 kHz, VBW=100 kHz.
Bandwidth: RBW=30 kHz, VBW=100 kHz.
- (3) The bandwidth is measured at an amplitude level reduced 20dB from the reference level. The reference level is the level of the highest amplitude signal observed from the transmitter at the fundamental frequency. Once the reference level is established, the equipment is conditioned with typical modulating signal to produce the worst –case (i.e the widest) bandwidth.
- (4) Measure the channel separation the spectrum analyzer was set to Resolution Bandwidth:30 kHz, and Video Bandwidth:100 kHz. Sweep Time set auto.

10.4 Deviation From Test Standard

No deviation

10.5 EUT Operating Condition

The EUT was set to the Hopping Mode for Channel Separation Test and continuously transmitting for the Bandwidth Test.

10.6 Test Data

Please refer to the Attachment G.

12. Peak Output Power Test

11.1 Test Standard and Limit

11.1.1 Test Standard

FCC Part 15.247 (b) (1)

11.1.2 Test Limit

| Test Item | Limit | Frequency Range(MHz) |
|-------------------|--|----------------------|
| Peak Output Power | Hopping Channels>75 Power<1W(30dBm) Other <125 mW(21dBm) | 2400~2483.5 |

11.2 Test Setup

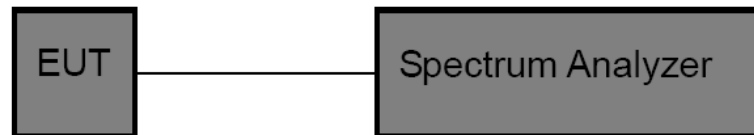

11.3 Test Procedure

- (1) The EUT was directly connected to the spectrum analyzer and antenna output port as show in the block diagram above.
- (2) Spectrum Setting:
Peak Detector: RBW=1 MHz, VBW=3 MHz for bandwidth less than 1MHz.
RBW=3 MHz, VBW ≥ RBW for bandwidth more than 1MHz.

11.4 Deviation From Test Standard

No deviation

11.5 EUT Operating Condition

The EUT was set to continuously transmitting in the max power during the test.

11.6 Test Data

Please refer to the Attachment H.

13. Antenna Requirement

12.1 Standard Requirement

12.1.1 Standard

FCC Part 15.203

12.1.2 Requirement

An intentional radiator shall be designed to ensure that no antenna other than that furnished by the responsible party shall be used with the device. The use of a permanently attached antenna or of an antenna that uses a unique coupling to the intentional radiator shall be considered sufficient to comply with the provisions of this Section. The manufacturer may design the unit so that a broken antenna can be replaced by the user, but the use of a standard antenna jack or electrical connector is prohibited.

12.2 Deviation From Test Standard

No deviation

12.3 Antenna Connected Construction

The gains of the antenna used for transmitting is 0.5 dBi, and the antenna connector is de-signed with permanent attachment and no consideration of replacement. Please see the EUT photo for details.

12.4 Result

The EUT antenna is a RP-SMA Antenna. It complies with the standard requirement.

| Antenna Type |
|--|
| <input checked="" type="checkbox"/> Permanent attached antenna |
| <input type="checkbox"/> Unique connector antenna |
| <input type="checkbox"/> Professional installation antenna |

Attachment A-- Conducted Emission Test Data

| | | | |
|---------------|-----------------------------|--------------------|-----|
| Temperature: | 24.6°C | Relative Humidity: | 42% |
| Test Voltage: | AC 120V/60 Hz | | |
| Terminal: | Line | | |
| Test Mode: | Mode 1 | | |
| Remark: | Only worse case is reported | | |

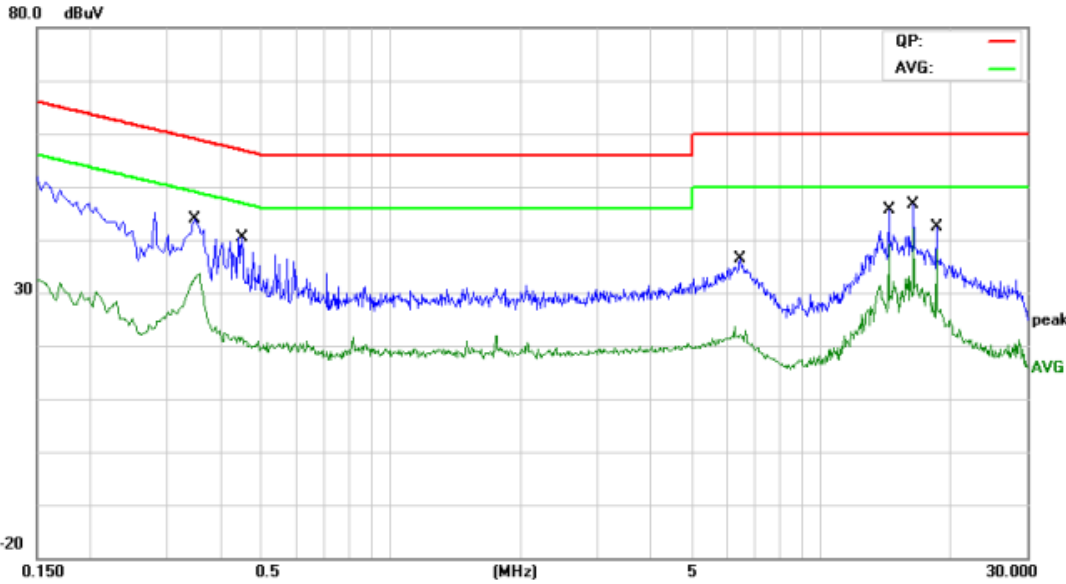

| No. | Mk. | Freq. MHz | Reading Level dBuV | Correct Factor dB | Measure- ment dBuV | Limit dBuV | Over dB | Detector |
|-----|-----|--------------|--------------------------|-------------------------|--------------------------|---------------|------------|----------|
| 1 | | 0.3500 | 30.51 | 9.70 | 40.21 | 58.96 | -18.75 | QP |
| 2 | | 0.3500 | 23.31 | 9.70 | 33.01 | 48.96 | -15.95 | AVG |
| 3 | | 0.4500 | 18.57 | 9.70 | 28.27 | 56.87 | -28.60 | QP |
| 4 | | 0.4500 | 10.63 | 9.70 | 20.33 | 46.87 | -26.54 | AVG |
| 5 | | 6.4540 | 19.49 | 9.83 | 29.32 | 60.00 | -30.68 | QP |
| 6 | | 6.4540 | 11.37 | 9.83 | 21.20 | 50.00 | -28.80 | AVG |
| 7 | | 14.3380 | 33.79 | 9.97 | 43.76 | 60.00 | -16.24 | QP |
| 8 | | 14.3380 | 28.62 | 9.97 | 38.59 | 50.00 | -11.41 | AVG |
| 9 | | 16.3860 | 34.45 | 10.00 | 44.45 | 60.00 | -15.55 | QP |
| 10 | * | 16.3860 | 31.76 | 10.00 | 41.76 | 50.00 | -8.24 | AVG |
| 11 | | 18.4340 | 30.77 | 10.00 | 40.77 | 60.00 | -19.23 | QP |
| 12 | | 18.4340 | 28.09 | 10.00 | 38.09 | 50.00 | -11.91 | AVG |

- Remark:
1. Corr. Factor (dB) = LISN Factor (dB) + Cable Loss (dB)
 2. Margin (dB) = QuasiPeak/Average (dBuV) - Limit (dBuV)

| | | | |
|----------------------|-----------------------------|---------------------------|-----|
| Temperature: | 24.6°C | Relative Humidity: | 42% |
| Test Voltage: | AC 120V/60 Hz | | |
| Terminal: | Neutral | | |
| Test Mode: | Mode 1 | | |
| Remark: | Only worse case is reported | | |

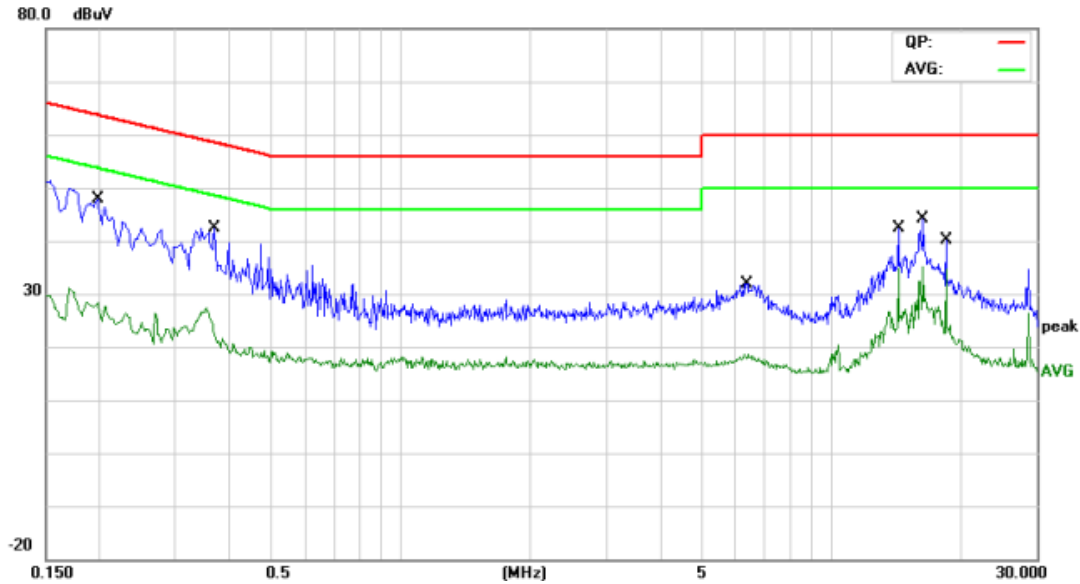

| No. | Mk. | Freq. MHz | Reading Level dBuV | Correct Factor dB | Measure- ment dBuV | Limit dBuV | Over dB | Detector |
|-----|-----|--------------|--------------------------|-------------------------|--------------------------|---------------|------------|----------|
| 1 | | 0.1980 | 32.60 | 9.80 | 42.40 | 63.69 | -21.29 | QP |
| 2 | | 0.1980 | 15.09 | 9.80 | 24.89 | 53.69 | -28.80 | AVG |
| 3 | | 0.3700 | 21.97 | 9.80 | 31.77 | 58.50 | -26.73 | QP |
| 4 | | 0.3700 | 11.98 | 9.80 | 21.78 | 48.50 | -26.72 | AVG |
| 5 | | 6.3659 | 14.58 | 9.87 | 24.45 | 60.00 | -35.55 | QP |
| 6 | | 6.3659 | 7.65 | 9.87 | 17.52 | 50.00 | -32.48 | AVG |
| 7 | | 14.3380 | 28.07 | 9.99 | 38.06 | 60.00 | -21.94 | QP |
| 8 | | 14.3380 | 22.21 | 9.99 | 32.20 | 50.00 | -17.80 | AVG |
| 9 | | 16.3819 | 34.14 | 10.00 | 44.14 | 60.00 | -15.86 | QP |
| 10 | * | 16.3819 | 30.15 | 10.00 | 40.15 | 50.00 | -9.85 | AVG |
| 11 | | 18.4340 | 28.22 | 10.00 | 38.22 | 60.00 | -21.78 | QP |
| 12 | | 18.4340 | 25.28 | 10.00 | 35.28 | 50.00 | -14.72 | AVG |

Remark:

1. Corr. Factor (dB) = LISN Factor (dB) + Cable Loss (dB)
2. Margin (dB) = QuasiPeak/Average (dBuV) - Limit (dBuV)

Attachment B-- Radiated Emission Test Data

9KHz~30MHz

From 9KHz to 30MHz: Conclusion: PASS

Note: The amplitude of spurious emissions which are attenuated by more than 20dB below the permissible value has no need to be reported.

30MHz~1GHz

| | | | |
|---------------|-----------------------------|--------------------|-----|
| Temperature: | 23.4°C | Relative Humidity: | 43% |
| Test Voltage: | AC 120V/60 Hz | | |
| Ant. Pol. | Horizontal | | |
| Test Mode: | Mode 1 2402MHz | | |
| Remark: | Only worse case is reported | | |

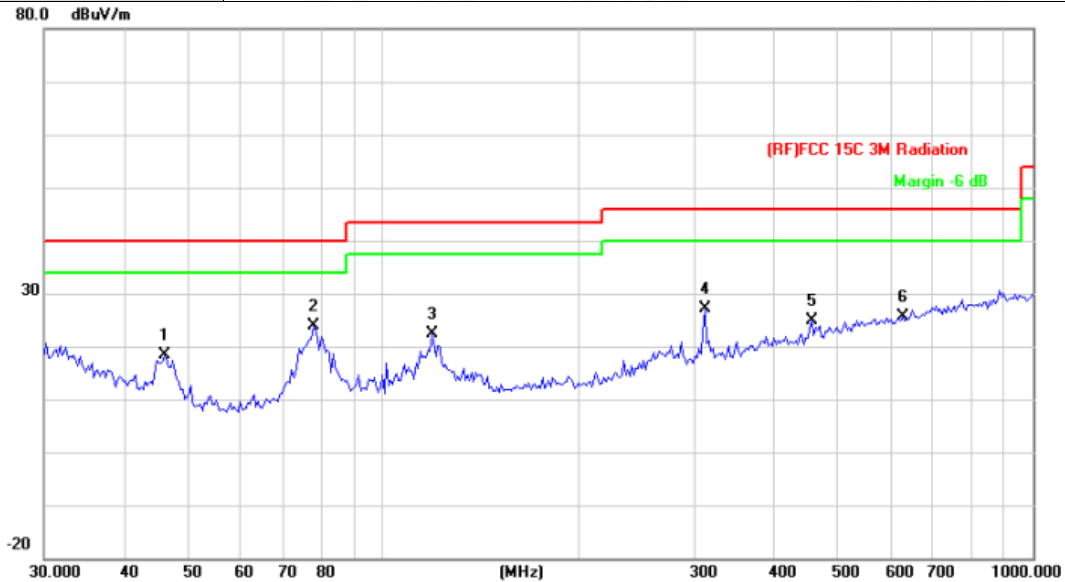

| No. | Mk. | Freq. MHz | Reading Level dBuV | Correct Factor dB/m | Measure- ment dBuV/m | Limit dBuV/m | Over dB | Detector |
|-----|-----|--------------|--------------------------|---------------------------|----------------------------|-----------------|------------|----------|
| 1 | | 46.0164 | 40.17 | -21.76 | 18.41 | 40.00 | -21.59 | peak |
| 2 | * | 77.8654 | 46.42 | -22.66 | 23.76 | 40.00 | -16.24 | peak |
| 3 | | 118.6014 | 44.45 | -22.18 | 22.27 | 43.50 | -21.23 | peak |
| 4 | | 312.1794 | 43.08 | -15.88 | 27.20 | 46.00 | -18.80 | peak |
| 5 | | 455.9058 | 36.62 | -11.77 | 24.85 | 46.00 | -21.15 | peak |
| 6 | | 629.4772 | 33.82 | -8.11 | 25.71 | 46.00 | -20.29 | peak |

*:Maximum data x:Over limit !:over margin

Remark:

- 1. Corr. = Antenna Factor (dB/m) + Cable Loss (dB)
- 2. QuasiPeak (dBµV/m)= Corr. (dB/m)+ Read Level (dBµV)
- 3. Margin (dB) = QuasiPeak (dBµV/m)-Limit QPK(dBµV/m)

| | | | |
|---------------|-----------------------------|--------------------|-----|
| Temperature: | 23.4°C | Relative Humidity: | 43% |
| Test Voltage: | AC 120V/60 Hz | | |
| Ant. Pol. | Vertical | | |
| Test Mode: | Mode 1 2402MHz | | |
| Remark: | Only worse case is reported | | |

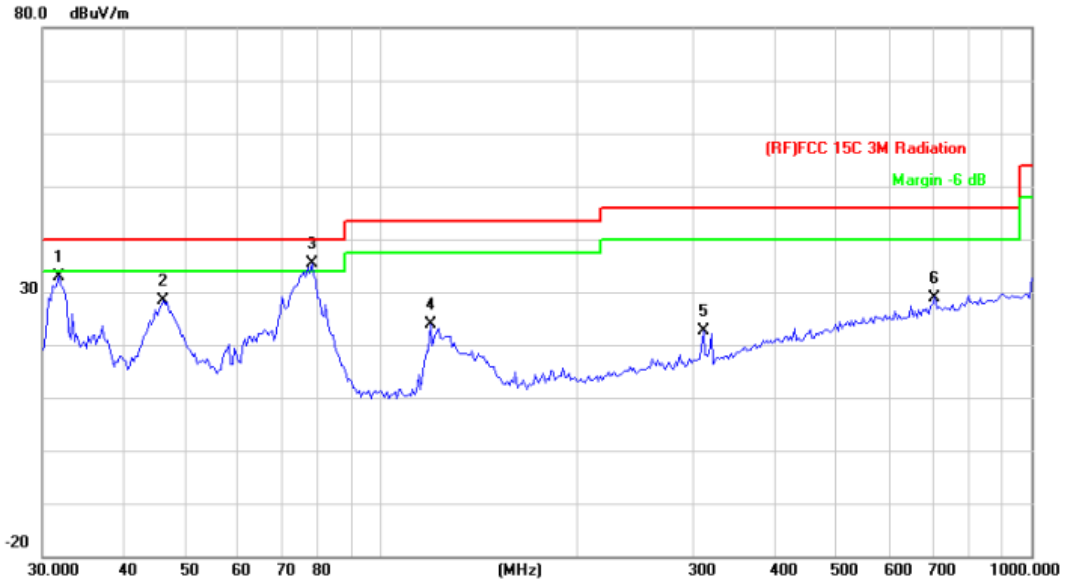

| No. | Mk. | Freq. MHz | Reading Level dBuV | Correct Factor dB/m | Measure- ment dBuV/m | Limit dBuV/m | Over dB | Detector |
|-----|-----|--------------|--------------------------|---------------------------|----------------------------|-----------------|------------|----------|
| 1 | | 31.7313 | 47.25 | -14.25 | 33.00 | 40.00 | -7.00 | peak |
| 2 | | 46.0164 | 50.02 | -21.76 | 28.26 | 40.00 | -11.74 | peak |
| 3 | * | 77.8654 | 58.14 | -22.66 | 35.48 | 40.00 | -4.52 | peak |
| 4 | | 118.6014 | 46.06 | -22.18 | 23.88 | 43.50 | -19.62 | peak |
| 5 | | 312.1794 | 38.43 | -15.88 | 22.55 | 46.00 | -23.45 | peak |
| 6 | | 709.1823 | 35.73 | -6.73 | 29.00 | 46.00 | -17.00 | peak |

*:Maximum data x:Over limit !:over margin

Remark:

1. Corr. = Antenna Factor (dB/m) + Cable Loss (dB)
2. QuasiPeak (dBµV/m)= Corr. (dB/m)+ Read Level (dBµV)
3. Margin (dB) = QuasiPeak (dBµV/m)-Limit QPK(dBµV/m)

Above 1GHz(Only worse case is reported)

| | | | |
|----------------------|----------------------|---------------------------|-----|
| Temperature: | 23.9°C | Relative Humidity: | 44% |
| Test Voltage: | AC 120V/60 Hz | | |
| Ant. Pol. | Horizontal | | |
| Test Mode: | TX GFSK Mode 2402MHz | | |

| No. | Mk. | Freq. | Reading Level | Correct Factor | Measurement | Limit | Over | Detector |
|-----|-----|----------|---------------|----------------|-------------|--------|--------|----------|
| | | MHz | dBuV | dB/m | dBuV/m | dBuV/m | dB | |
| 1 | * | 4803.624 | 28.38 | 13.01 | 41.39 | 54.00 | -12.61 | AVG |
| 2 | | 4803.968 | 42.22 | 13.01 | 55.23 | 74.00 | -18.77 | peak |

Remark:

1. Corr. = Antenna Factor (dB/m) + Cable Loss (dB)
2. Peak/AVG (dBμV/m)= Corr. (dB/m)+ Read Level (dBμV)
3. Margin (dB) = Peak/AVG (dBμV/m)-Limit PK/AVG(dBμV/m)
4. The tests evaluated 1-26.5GHz, The testing has been conformed to the 10th harmonic of the highest fundamental frequency.
5. No report for the emission which more than 20dB below the prescribed limit.

| | | | |
|----------------------|----------------------|---------------------------|-----|
| Temperature: | 23.6°C | Relative Humidity: | 45% |
| Test Voltage: | AC 120V/60 Hz | | |
| Ant. Pol. | Vertical | | |
| Test Mode: | TX GFSK Mode 2402MHz | | |

| No. | Mk. | Freq. | Reading Level | Correct Factor | Measurement | Limit | Over | Detector |
|-----|-----|----------|---------------|----------------|-------------|--------|--------|----------|
| | | MHz | dBuV | dB/m | dBuV/m | dBuV/m | dB | |
| 1 | * | 4803.720 | 28.17 | 13.01 | 41.18 | 54.00 | -12.82 | AVG |
| 2 | | 4804.014 | 43.49 | 13.01 | 56.50 | 74.00 | -17.50 | peak |

Remark:

1. Corr. = Antenna Factor (dB/m) + Cable Loss (dB)
2. Peak/AVG (dBμV/m)= Corr. (dB/m)+ Read Level (dBμV)
3. Margin (dB) = Peak/AVG (dBμV/m)-Limit PK/AVG(dBμV/m)
4. The tests evaluated 1-26.5GHz, The testing has been conformed to the 10th harmonic of the highest fundamental frequency.
5. No report for the emission which more than 20dB below the prescribed limit.

| | | | |
|----------------------|----------------------|---------------------------|-----|
| Temperature: | 23.9°C | Relative Humidity: | 44% |
| Test Voltage: | AC 120V/60 Hz | | |
| Ant. Pol. | Horizontal | | |
| Test Mode: | TX GFSK Mode 2441MHz | | |

| No. | Mk. | Freq. | Reading Level | Correct Factor | Measurement | Limit | Over | Detector |
|-----|-----|----------|---------------|----------------|-------------|--------|--------|----------|
| | | MHz | dBuV | dB/m | dBuV/m | dBuV/m | dB | |
| 1 | * | 4882.204 | 28.57 | 13.59 | 42.16 | 54.00 | -11.84 | AVG |
| 2 | | 4882.446 | 42.75 | 13.59 | 56.34 | 74.00 | -17.66 | peak |

Remark:

1. Corr. = Antenna Factor (dB/m) + Cable Loss (dB)
2. Peak/AVG (dBμV/m)= Corr. (dB/m)+ Read Level (dBμV)
3. Margin (dB) = Peak/AVG (dBμV/m)-Limit PK/AVG(dBμV/m)
4. The tests evaluated 1-26.5GHz, The testing has been conformed to the 10th harmonic of the highest fundamental frequency.
5. No report for the emission which more than 20dB below the prescribed limit.

| | | | |
|----------------------|----------------------|---------------------------|-----|
| Temperature: | 23.9°C | Relative Humidity: | 44% |
| Test Voltage: | AC 120V/60 Hz | | |
| Ant. Pol. | Vertical | | |
| Test Mode: | TX GFSK Mode 2441MHz | | |

| No. | Mk. | Freq. | Reading Level | Correct Factor | Measurement | Limit | Over | Detector |
|-----|-----|----------|---------------|----------------|-------------|--------|--------|----------|
| | | MHz | dBuV | dB/m | dBuV/m | dBuV/m | dB | |
| 1 | | 4881.868 | 42.38 | 13.59 | 55.97 | 74.00 | -18.03 | peak |
| 2 | * | 4882.378 | 28.74 | 13.59 | 42.33 | 54.00 | -11.67 | AVG |

Remark:

1. Corr. = Antenna Factor (dB/m) + Cable Loss (dB)
2. Peak/AVG (dBμV/m)= Corr. (dB/m)+ Read Level (dBμV)
3. Margin (dB) = Peak/AVG (dBμV/m)-Limit PK/AVG(dBμV/m)
4. The tests evaluated 1-26.5GHz, The testing has been conformed to the 10th harmonic of the highest fundamental frequency.
5. No report for the emission which more than 20dB below the prescribed limit.

| | | | |
|----------------------|----------------------|---------------------------|-----|
| Temperature: | 23.9°C | Relative Humidity: | 44% |
| Test Voltage: | AC 120V/60 Hz | | |
| Ant. Pol. | Horizontal | | |
| Test Mode: | TX GFSK Mode 2480MHz | | |

| No. | Mk. | Freq. | Reading Level | Correct Factor | Measurement | Limit | Over | |
|-----|-----|----------|---------------|----------------|-------------|--------|--------|----------|
| | | MHz | dBuV | dB/m | dBuV/m | dBuV/m | dB | Detector |
| 1 | * | 4959.852 | 28.57 | 14.15 | 42.72 | 54.00 | -11.28 | AVG |
| 2 | | 4960.108 | 41.80 | 14.15 | 55.95 | 74.00 | -18.05 | peak |

Remark:

1. Corr. = Antenna Factor (dB/m) + Cable Loss (dB)
2. Peak/AVG (dBuV/m)= Corr. (dB/m)+ Read Level (dBuV)
3. Margin (dB) = Peak/AVG (dBuV/m)-Limit PK/AVG(dBuV/m)
4. The tests evaluated 1-26.5GHz, The testing has been conformed to the 10th harmonic of the highest fundamental frequency.
5. No report for the emission which more than 20dB below the prescribed limit.

| | | | |
|----------------------|----------------------|---------------------------|-----|
| Temperature: | 23.9°C | Relative Humidity: | 44% |
| Test Voltage: | AC 120V/60 Hz | | |
| Ant. Pol. | Vertical | | |
| Test Mode: | TX GFSK Mode 2480MHz | | |

| No. | Mk. | Freq. | Reading Level | Correct Factor | Measurement | Limit | Over | |
|-----|-----|----------|---------------|----------------|-------------|--------|--------|----------|
| | | MHz | dBuV | dB/m | dBuV/m | dBuV/m | dB | Detector |
| 1 | * | 4960.098 | 28.75 | 14.15 | 42.90 | 54.00 | -11.10 | AVG |
| 2 | | 4960.230 | 42.45 | 14.15 | 56.60 | 74.00 | -17.40 | peak |

Remark:

1. Corr. = Antenna Factor (dB/m) + Cable Loss (dB)
2. Peak/AVG (dBuV/m)= Corr. (dB/m)+ Read Level (dBuV)
3. Margin (dB) = Peak/AVG (dBuV/m)-Limit PK/AVG(dBuV/m)
4. The tests evaluated 1-26.5GHz, The testing has been conformed to the 10th harmonic of the highest fundamental frequency.
5. No report for the emission which more than 20dB below the prescribed limit.

| | | | |
|----------------------|--------------------------------|---------------------------|-----|
| Temperature: | 23.9°C | Relative Humidity: | 44% |
| Test Voltage: | AC 120V/60 Hz | | |
| Ant. Pol. | Horizontal | | |
| Test Mode: | TX π /4-DQPSK Mode 2402MHz | | |

| No. | Mk. | Freq. | Reading Level | Correct Factor | Measurement | Limit | Over | Detector |
|-----|-----|----------|---------------|----------------|-------------|--------|--------|----------|
| | | MHz | dBuV | dB/m | dBuV/m | dBuV/m | dB | |
| 1 | * | 4804.078 | 28.24 | 13.01 | 41.25 | 54.00 | -12.75 | AVG |
| 2 | | 4804.118 | 42.28 | 13.02 | 55.30 | 74.00 | -18.70 | peak |

Remark:

1. Corr. = Antenna Factor (dB/m) + Cable Loss (dB)
2. Peak/AVG (dB μ V/m)= Corr. (dB/m)+ Read Level (dB μ V)
3. Margin (dB) = Peak/AVG (dB μ V/m)-Limit PK/AVG(dB μ V/m)
4. The tests evaluated 1-26.5GHz, The testing has been conformed to the 10th harmonic of the highest fundamental frequency.
5. No report for the emission which more than 20dB below the prescribed limit.

| | | | |
|----------------------|--------------------------------|---------------------------|-----|
| Temperature: | 23.9°C | Relative Humidity: | 44% |
| Test Voltage: | AC 120V/60 Hz | | |
| Ant. Pol. | Vertical | | |
| Test Mode: | TX π /4-DQPSK Mode 2402MHz | | |

| No. | Mk. | Freq. | Reading Level | Correct Factor | Measurement | Limit | Over | Detector |
|-----|-----|----------|---------------|----------------|-------------|--------|--------|----------|
| | | MHz | dBuV | dB/m | dBuV/m | dBuV/m | dB | |
| 1 | | 4804.228 | 42.74 | 13.02 | 55.76 | 74.00 | -18.24 | peak |
| 2 | * | 4804.320 | 28.03 | 13.02 | 41.05 | 54.00 | -12.95 | AVG |

Remark:

1. Corr. = Antenna Factor (dB/m) + Cable Loss (dB)
2. Peak/AVG (dB μ V/m)= Corr. (dB/m)+ Read Level (dB μ V)
3. Margin (dB) = Peak/AVG (dB μ V/m)-Limit PK/AVG(dB μ V/m)
4. The tests evaluated 1-26.5GHz, The testing has been conformed to the 10th harmonic of the highest fundamental frequency.
5. No report for the emission which more than 20dB below the prescribed limit.

| | | | |
|----------------------|--------------------------------|---------------------------|-----|
| Temperature: | 23.9°C | Relative Humidity: | 44% |
| Test Voltage: | AC 120V/60 Hz | | |
| Ant. Pol. | Horizontal | | |
| Test Mode: | TX π /4-DQPSK Mode 2441MHz | | |

| No. | Mk. | Freq. | Reading Level | Correct Factor | Measurement | Limit | Over | Detector |
|-----|-----|----------|---------------|----------------|-------------|--------|--------|----------|
| | | MHz | dBuV | dB/m | dBuV/m | dBuV/m | dB | |
| 1 | | 4881.670 | 42.16 | 13.59 | 55.75 | 74.00 | -18.25 | peak |
| 2 | * | 4881.908 | 28.57 | 13.59 | 42.16 | 54.00 | -11.84 | AVG |

Remark:

1. Corr. = Antenna Factor (dB/m) + Cable Loss (dB)
2. Peak/AVG (dB μ V/m)= Corr. (dB/m)+ Read Level (dB μ V)
3. Margin (dB) = Peak/AVG (dB μ V/m)-Limit PK/AVG(dB μ V/m)
4. The tests evaluated 1-26.5GHz, The testing has been conformed to the 10th harmonic of the highest fundamental frequency.
5. No report for the emission which more than 20dB below the prescribed limit.

| | | | |
|----------------------|--------------------------------|---------------------------|-----|
| Temperature: | 23.0°C | Relative Humidity: | 44% |
| Test Voltage: | AC 120V/60 Hz | | |
| Ant. Pol. | Vertical | | |
| Test Mode: | TX π /4-DQPSK Mode 2441MHz | | |

| No. | Mk. | Freq. | Reading Level | Correct Factor | Measurement | Limit | Over | Detector |
|-----|-----|----------|---------------|----------------|-------------|--------|--------|----------|
| | | MHz | dBuV | dB/m | dBuV/m | dBuV/m | dB | |
| 1 | * | 4882.150 | 28.67 | 13.59 | 42.26 | 54.00 | -11.74 | AVG |
| 2 | | 4882.372 | 42.38 | 13.59 | 55.97 | 74.00 | -18.03 | peak |

Remark:

1. Corr. = Antenna Factor (dB/m) + Cable Loss (dB)
2. Peak/AVG (dB μ V/m)= Corr. (dB/m)+ Read Level (dB μ V)
3. Margin (dB) = Peak/AVG (dB μ V/m)-Limit PK/AVG(dB μ V/m)
4. The tests evaluated 1-26.5GHz, The testing has been conformed to the 10th harmonic of the highest fundamental frequency.
5. No report for the emission which more than 20dB below the prescribed limit.

| Temperature: | 23.9°C | | Relative Humidity: | 44% | | | | |
|----------------------|--------------------------------|--------------|---------------------------|---------------------------|----------------------------|-----------------|------------|----------|
| Test Voltage: | AC 120V/60 Hz | | | | | | | |
| Ant. Pol. | Horizontal | | | | | | | |
| Test Mode: | TX π /4-DQPSK Mode 2480MHz | | | | | | | |
| No. | Mk. | Freq. MHz | Reading Level dBuV | Correct Factor dB/m | Measure- ment dBuV/m | Limit dBuV/m | Over dB | Detector |
| 1 | * | 4960.174 | 28.58 | 14.15 | 42.73 | 54.00 | -11.27 | AVG |
| 2 | | 4960.422 | 41.62 | 14.16 | 55.78 | 74.00 | -18.22 | peak |

Remark:

1. Corr. = Antenna Factor (dB/m) + Cable Loss (dB)
2. Peak/AVG (dB μ V/m)= Corr. (dB/m)+ Read Level (dB μ V)
3. Margin (dB) = Peak/AVG (dB μ V/m)-Limit PK/AVG(dB μ V/m)
4. The tests evaluated 1-26.5GHz, The testing has been conformed to the 10th harmonic of the highest fundamental frequency.
5. No report for the emission which more than 20dB below the prescribed limit.

| Temperature: | 23.9°C | | Relative Humidity: | 44% | | | | |
|----------------------|--------------------------------|--------------|---------------------------|---------------------------|----------------------------|-----------------|------------|----------|
| Test Voltage: | AC 120V/60 Hz | | | | | | | |
| Ant. Pol. | Vertical | | | | | | | |
| Test Mode: | TX π /4-DQPSK Mode 2480MHz | | | | | | | |
| No. | Mk. | Freq. MHz | Reading Level dBuV | Correct Factor dB/m | Measure- ment dBuV/m | Limit dBuV/m | Over dB | Detector |
| 1 | | 4959.774 | 42.42 | 14.15 | 56.57 | 74.00 | -17.43 | peak |
| 2 | * | 4959.986 | 28.67 | 14.15 | 42.82 | 54.00 | -11.18 | AVG |

Remark:

1. Corr. = Antenna Factor (dB/m) + Cable Loss (dB)
2. Peak/AVG (dB μ V/m)= Corr. (dB/m)+ Read Level (dB μ V)
3. Margin (dB) = Peak/AVG (dB μ V/m)-Limit PK/AVG(dB μ V/m)
4. The tests evaluated 1-26.5GHz, The testing has been conformed to the 10th harmonic of the highest fundamental frequency.
5. No report for the emission which more than 20dB below the prescribed limit.

| Temperature: | 23.9°C | Relative Humidity: | 44% | | | | | | | | | | | | | | | | | | | | | | | | | | | | | | | | | | | | |
|--|-----------------------|---------------------------|---------------|----------------|-------------|--------|---------------|----------------|-------------|-------|------|--|--|--|-----|------|------|--------|--------|----|----------|---|---|----------|-------|-------|-------|-------|--------|-----|---|--|----------|-------|-------|-------|-------|--------|------|
| Test Voltage: | AC 120V/60 Hz | | | | | | | | | | | | | | | | | | | | | | | | | | | | | | | | | | | | | | |
| Ant. Pol. | Horizontal | | | | | | | | | | | | | | | | | | | | | | | | | | | | | | | | | | | | | | |
| Test Mode: | TX 8DPSK Mode 2402MHz | | | | | | | | | | | | | | | | | | | | | | | | | | | | | | | | | | | | | | |
| <table border="1"> <thead> <tr> <th>No.</th> <th>Mk.</th> <th>Freq.</th> <th>Reading Level</th> <th>Correct Factor</th> <th>Measurement</th> <th>Limit</th> <th>Over</th> <th></th> </tr> <tr> <th></th> <th></th> <th>MHz</th> <th>dBuV</th> <th>dB/m</th> <th>dBuV/m</th> <th>dBuV/m</th> <th>dB</th> <th>Detector</th> </tr> </thead> <tbody> <tr> <td>1</td> <td>*</td> <td>4803.816</td> <td>28.00</td> <td>13.01</td> <td>41.01</td> <td>54.00</td> <td>-12.99</td> <td>AVG</td> </tr> <tr> <td>2</td> <td></td> <td>4803.940</td> <td>42.35</td> <td>13.01</td> <td>55.36</td> <td>74.00</td> <td>-18.64</td> <td>peak</td> </tr> </tbody> </table> | | | | No. | Mk. | Freq. | Reading Level | Correct Factor | Measurement | Limit | Over | | | | MHz | dBuV | dB/m | dBuV/m | dBuV/m | dB | Detector | 1 | * | 4803.816 | 28.00 | 13.01 | 41.01 | 54.00 | -12.99 | AVG | 2 | | 4803.940 | 42.35 | 13.01 | 55.36 | 74.00 | -18.64 | peak |
| No. | Mk. | Freq. | Reading Level | Correct Factor | Measurement | Limit | Over | | | | | | | | | | | | | | | | | | | | | | | | | | | | | | | | |
| | | MHz | dBuV | dB/m | dBuV/m | dBuV/m | dB | Detector | | | | | | | | | | | | | | | | | | | | | | | | | | | | | | | |
| 1 | * | 4803.816 | 28.00 | 13.01 | 41.01 | 54.00 | -12.99 | AVG | | | | | | | | | | | | | | | | | | | | | | | | | | | | | | | |
| 2 | | 4803.940 | 42.35 | 13.01 | 55.36 | 74.00 | -18.64 | peak | | | | | | | | | | | | | | | | | | | | | | | | | | | | | | | |
| <p>Remark:</p> <ol style="list-style-type: none"> 1. Corr. = Antenna Factor (dB/m) + Cable Loss (dB) 2. Peak/AVG (dBuV/m)= Corr. (dB/m)+ Read Level (dBuV) 3. Margin (dB) = Peak/AVG (dBuV/m)-Limit PK/AVG(dBuV/m) 4. The tests evaluated 1-26.5GHz, The testing has been conformed to the 10th harmonic of the highest fundamental frequency. 5. No report for the emission which more than 20dB below the prescribed limit. | | | | | | | | | | | | | | | | | | | | | | | | | | | | | | | | | | | | | | | |

| Temperature: | 23.9°C | Relative Humidity: | 44% | | | | | | | | | | | | | | | | | | | | | | | | | | | | | | | | | | | | |
|--|-----------------------|---------------------------|---------------|----------------|-------------|--------|---------------|----------------|-------------|-------|------|--|--|--|-----|------|------|--------|--------|----|----------|---|--|----------|-------|-------|-------|-------|--------|------|---|---|----------|-------|-------|-------|-------|--------|-----|
| Test Voltage: | AC 120V/60 Hz | | | | | | | | | | | | | | | | | | | | | | | | | | | | | | | | | | | | | | |
| Ant. Pol. | Vertical | | | | | | | | | | | | | | | | | | | | | | | | | | | | | | | | | | | | | | |
| Test Mode: | TX 8DPSK Mode 2402MHz | | | | | | | | | | | | | | | | | | | | | | | | | | | | | | | | | | | | | | |
| <table border="1"> <thead> <tr> <th>No.</th> <th>Mk.</th> <th>Freq.</th> <th>Reading Level</th> <th>Correct Factor</th> <th>Measurement</th> <th>Limit</th> <th>Over</th> <th></th> </tr> <tr> <th></th> <th></th> <th>MHz</th> <th>dBuV</th> <th>dB/m</th> <th>dBuV/m</th> <th>dBuV/m</th> <th>dB</th> <th>Detector</th> </tr> </thead> <tbody> <tr> <td>1</td> <td></td> <td>4803.762</td> <td>41.78</td> <td>13.01</td> <td>54.79</td> <td>74.00</td> <td>-19.21</td> <td>peak</td> </tr> <tr> <td>2</td> <td>*</td> <td>4804.154</td> <td>28.23</td> <td>13.02</td> <td>41.25</td> <td>54.00</td> <td>-12.75</td> <td>AVG</td> </tr> </tbody> </table> | | | | No. | Mk. | Freq. | Reading Level | Correct Factor | Measurement | Limit | Over | | | | MHz | dBuV | dB/m | dBuV/m | dBuV/m | dB | Detector | 1 | | 4803.762 | 41.78 | 13.01 | 54.79 | 74.00 | -19.21 | peak | 2 | * | 4804.154 | 28.23 | 13.02 | 41.25 | 54.00 | -12.75 | AVG |
| No. | Mk. | Freq. | Reading Level | Correct Factor | Measurement | Limit | Over | | | | | | | | | | | | | | | | | | | | | | | | | | | | | | | | |
| | | MHz | dBuV | dB/m | dBuV/m | dBuV/m | dB | Detector | | | | | | | | | | | | | | | | | | | | | | | | | | | | | | | |
| 1 | | 4803.762 | 41.78 | 13.01 | 54.79 | 74.00 | -19.21 | peak | | | | | | | | | | | | | | | | | | | | | | | | | | | | | | | |
| 2 | * | 4804.154 | 28.23 | 13.02 | 41.25 | 54.00 | -12.75 | AVG | | | | | | | | | | | | | | | | | | | | | | | | | | | | | | | |
| <p>Remark:</p> <ol style="list-style-type: none"> 1. Corr. = Antenna Factor (dB/m) + Cable Loss (dB) 2. Peak/AVG (dBuV/m)= Corr. (dB/m)+ Read Level (dBuV) 3. Margin (dB) = Peak/AVG (dBuV/m)-Limit PK/AVG(dBuV/m) 4. The tests evaluated 1-26.5GHz, The testing has been conformed to the 10th harmonic of the highest fundamental frequency. 5. No report for the emission which more than 20dB below the prescribed limit. | | | | | | | | | | | | | | | | | | | | | | | | | | | | | | | | | | | | | | | |

| | | | |
|----------------------|-----------------------|---------------------------|-----|
| Temperature: | 23.9°C | Relative Humidity: | 44% |
| Test Voltage: | AC 120V/60 Hz | | |
| Ant. Pol. | Horizontal | | |
| Test Mode: | TX 8DPSK Mode 2441MHz | | |

| No. | Mk. | Freq. | Reading Level | Correct Factor | Measurement | Limit | Over | Detector |
|-----|-----|----------|---------------|----------------|-------------|--------|--------|----------|
| | | MHz | dBuV | dB/m | dBuV/m | dBuV/m | dB | |
| 1 | | 4881.786 | 42.57 | 13.59 | 56.16 | 74.00 | -17.84 | peak |
| 2 | * | 4881.856 | 28.54 | 13.59 | 42.13 | 54.00 | -11.87 | AVG |

Remark:

1. Corr. = Antenna Factor (dB/m) + Cable Loss (dB)
2. Peak/AVG (dBuV/m)= Corr. (dB/m)+ Read Level (dBuV)
3. Margin (dB) = Peak/AVG (dBuV/m)-Limit PK/AVG(dBuV/m)
4. The tests evaluated 1-26.5GHz, The testing has been conformed to the 10th harmonic of the highest fundamental frequency.
5. No report for the emission which more than 20dB below the prescribed limit.

| | | | |
|----------------------|-----------------------|---------------------------|-----|
| Temperature: | 23.9°C | Relative Humidity: | 44% |
| Test Voltage: | AC 120V/60 Hz | | |
| Ant. Pol. | Vertical | | |
| Test Mode: | TX 8DPSK Mode 2441MHz | | |

| No. | Mk. | Freq. | Reading Level | Correct Factor | Measurement | Limit | Over | Detector |
|-----|-----|----------|---------------|----------------|-------------|--------|--------|----------|
| | | MHz | dBuV | dB/m | dBuV/m | dBuV/m | dB | |
| 1 | * | 4882.344 | 28.47 | 13.59 | 42.06 | 54.00 | -11.94 | AVG |
| 2 | | 4882.430 | 42.44 | 13.59 | 56.03 | 74.00 | -17.97 | peak |

Remark:

1. Corr. = Antenna Factor (dB/m) + Cable Loss (dB)
2. Peak/AVG (dBuV/m)= Corr. (dB/m)+ Read Level (dBuV)
3. Margin (dB) = Peak/AVG (dBuV/m)-Limit PK/AVG(dBuV/m)
4. The tests evaluated 1-26.5GHz, The testing has been conformed to the 10th harmonic of the highest fundamental frequency.
5. No report for the emission which more than 20dB below the prescribed limit.

| Temperature: | 23.9°C | Relative Humidity: | 44% | | | | | | | | | | | | | | | | | | | | | | | | | | | | | | | | | | | | |
|--|-----------------------|---------------------------|---------------|----------------|-------------|--------|---------------|----------------|-------------|-------|------|----------|--|--|-----|------|------|--------|--------|----|--|---|---|----------|-------|-------|-------|-------|--------|-----|---|--|----------|-------|-------|-------|-------|--------|------|
| Test Voltage: | AC 120V/60 Hz | | | | | | | | | | | | | | | | | | | | | | | | | | | | | | | | | | | | | | |
| Ant. Pol. | Horizontal | | | | | | | | | | | | | | | | | | | | | | | | | | | | | | | | | | | | | | |
| Test Mode: | TX 8DPSK Mode 2480MHz | | | | | | | | | | | | | | | | | | | | | | | | | | | | | | | | | | | | | | |
| <table border="1"> <thead> <tr> <th>No.</th> <th>Mk.</th> <th>Freq.</th> <th>Reading Level</th> <th>Correct Factor</th> <th>Measurement</th> <th>Limit</th> <th>Over</th> <th>Detector</th> </tr> <tr> <th></th> <th></th> <th>MHz</th> <th>dBuV</th> <th>dB/m</th> <th>dBuV/m</th> <th>dBuV/m</th> <th>dB</th> <th></th> </tr> </thead> <tbody> <tr> <td>1</td> <td>*</td> <td>4960.126</td> <td>28.38</td> <td>14.15</td> <td>42.53</td> <td>54.00</td> <td>-11.47</td> <td>AVG</td> </tr> <tr> <td>2</td> <td></td> <td>4960.206</td> <td>42.93</td> <td>14.15</td> <td>57.08</td> <td>74.00</td> <td>-16.92</td> <td>peak</td> </tr> </tbody> </table> | | | | No. | Mk. | Freq. | Reading Level | Correct Factor | Measurement | Limit | Over | Detector | | | MHz | dBuV | dB/m | dBuV/m | dBuV/m | dB | | 1 | * | 4960.126 | 28.38 | 14.15 | 42.53 | 54.00 | -11.47 | AVG | 2 | | 4960.206 | 42.93 | 14.15 | 57.08 | 74.00 | -16.92 | peak |
| No. | Mk. | Freq. | Reading Level | Correct Factor | Measurement | Limit | Over | Detector | | | | | | | | | | | | | | | | | | | | | | | | | | | | | | | |
| | | MHz | dBuV | dB/m | dBuV/m | dBuV/m | dB | | | | | | | | | | | | | | | | | | | | | | | | | | | | | | | | |
| 1 | * | 4960.126 | 28.38 | 14.15 | 42.53 | 54.00 | -11.47 | AVG | | | | | | | | | | | | | | | | | | | | | | | | | | | | | | | |
| 2 | | 4960.206 | 42.93 | 14.15 | 57.08 | 74.00 | -16.92 | peak | | | | | | | | | | | | | | | | | | | | | | | | | | | | | | | |
| Remark: 1. Corr. = Antenna Factor (dB/m) + Cable Loss (dB) 2. Peak/AVG (dBμV/m)= Corr. (dB/m)+ Read Level (dBμV) 3. Margin (dB) = Peak/AVG (dBμV/m)-Limit PK/AVG(dBμV/m) 4. The tests evaluated 1-26.5GHz, The testing has been conformed to the 10th harmonic of the highest fundamental frequency. 5. No report for the emission which more than 20dB below the prescribed limit. | | | | | | | | | | | | | | | | | | | | | | | | | | | | | | | | | | | | | | | |

| Temperature: | 23.9°C | Relative Humidity: | 44% | | | | | | | | | | | | | | | | | | | | | | | | | | | | | | | | | | | | |
|--|-----------------------|---------------------------|---------------|----------------|-------------|--------|---------------|----------------|-------------|-------|------|----------|--|--|-----|------|------|--------|--------|----|--|---|--|----------|-------|-------|-------|-------|--------|------|---|---|----------|-------|-------|-------|-------|--------|-----|
| Test Voltage: | AC 120V/60 Hz | | | | | | | | | | | | | | | | | | | | | | | | | | | | | | | | | | | | | | |
| Ant. Pol. | Vertical | | | | | | | | | | | | | | | | | | | | | | | | | | | | | | | | | | | | | | |
| Test Mode: | TX 8DPSK Mode 2480MHz | | | | | | | | | | | | | | | | | | | | | | | | | | | | | | | | | | | | | | |
| <table border="1"> <thead> <tr> <th>No.</th> <th>Mk.</th> <th>Freq.</th> <th>Reading Level</th> <th>Correct Factor</th> <th>Measurement</th> <th>Limit</th> <th>Over</th> <th>Detector</th> </tr> <tr> <th></th> <th></th> <th>MHz</th> <th>dBuV</th> <th>dB/m</th> <th>dBuV/m</th> <th>dBuV/m</th> <th>dB</th> <th></th> </tr> </thead> <tbody> <tr> <td>1</td> <td></td> <td>4959.670</td> <td>42.57</td> <td>14.15</td> <td>56.72</td> <td>74.00</td> <td>-17.28</td> <td>peak</td> </tr> <tr> <td>2</td> <td>*</td> <td>4959.820</td> <td>28.49</td> <td>14.15</td> <td>42.64</td> <td>54.00</td> <td>-11.36</td> <td>AVG</td> </tr> </tbody> </table> | | | | No. | Mk. | Freq. | Reading Level | Correct Factor | Measurement | Limit | Over | Detector | | | MHz | dBuV | dB/m | dBuV/m | dBuV/m | dB | | 1 | | 4959.670 | 42.57 | 14.15 | 56.72 | 74.00 | -17.28 | peak | 2 | * | 4959.820 | 28.49 | 14.15 | 42.64 | 54.00 | -11.36 | AVG |
| No. | Mk. | Freq. | Reading Level | Correct Factor | Measurement | Limit | Over | Detector | | | | | | | | | | | | | | | | | | | | | | | | | | | | | | | |
| | | MHz | dBuV | dB/m | dBuV/m | dBuV/m | dB | | | | | | | | | | | | | | | | | | | | | | | | | | | | | | | | |
| 1 | | 4959.670 | 42.57 | 14.15 | 56.72 | 74.00 | -17.28 | peak | | | | | | | | | | | | | | | | | | | | | | | | | | | | | | | |
| 2 | * | 4959.820 | 28.49 | 14.15 | 42.64 | 54.00 | -11.36 | AVG | | | | | | | | | | | | | | | | | | | | | | | | | | | | | | | |
| Remark: 1. Corr. = Antenna Factor (dB/m) + Cable Loss (dB) 2. Peak/AVG (dBμV/m)= Corr. (dB/m)+ Read Level (dBμV) 3. Margin (dB) = Peak/AVG (dBμV/m)-Limit PK/AVG(dBμV/m) 4. The tests evaluated 1-26.5GHz, The testing has been conformed to the 10th harmonic of the highest fundamental frequency. 5. No report for the emission which more than 20dB below the prescribed limit. | | | | | | | | | | | | | | | | | | | | | | | | | | | | | | | | | | | | | | | |

Attachment C-- Emissions in Restricted Bands Test Data

| Mode | Frequency (MHz) | Antenna | Hopping Mode | Spur Freq (MHz) | Power (dBm) | Gain (dBi) | E (dBuV/m) | Detector | Limit (dBuV/m) | Verdict |
|------|-----------------|---------|--------------|-----------------|-------------|------------|------------|----------|----------------|---------|
| GFSK | 2402 | Ant1 | No-Hopping | 2310 | -41.76 | 2 | 55.5 | Peak | 74 | Pass |
| | 2402 | Ant1 | No-Hopping | 2310 | -55.16 | 2 | 42.1 | Average | 54 | Pass |
| | 2402 | Ant1 | No-Hopping | 2379.6 | -39.68 | 2 | 57.58 | Peak | 74 | Pass |
| | 2402 | Ant1 | No-Hopping | 2362.8 | -54.28 | 2 | 42.98 | Average | 54 | Pass |
| | 2402 | Ant1 | No-Hopping | 2390 | -41.87 | 2 | 55.39 | Peak | 74 | Pass |
| | 2402 | Ant1 | No-Hopping | 2390 | -54.65 | 2 | 42.61 | Average | 54 | Pass |
| | 2480 | Ant1 | No-Hopping | 2483.5 | -41.15 | 2 | 56.11 | Peak | 74 | Pass |
| | 2480 | Ant1 | No-Hopping | 2483.5 | -54.4 | 2 | 42.86 | Average | 54 | Pass |
| | 2480 | Ant1 | No-Hopping | 2498.056 | -39.37 | 2 | 57.89 | Peak | 74 | Pass |
| | 2480 | Ant1 | No-Hopping | 2490.664 | -54.21 | 2 | 43.05 | Average | 54 | Pass |
| | 2480 | Ant1 | No-Hopping | 2500 | -41.49 | 2 | 55.77 | Peak | 74 | Pass |
| | 2480 | Ant1 | No-Hopping | 2500 | -54.48 | 2 | 42.78 | Average | 54 | Pass |
| | 2402 | Ant1 | No-Hopping | 2310 | -42.49 | 2 | 54.77 | Peak | 74 | Pass |
| | 2402 | Ant1 | No-Hopping | 2310 | -55.2 | 2 | 42.06 | Average | 54 | Pass |
| | 2402 | Ant1 | No-Hopping | 2376.624 | -40.43 | 2 | 56.83 | Peak | 74 | Pass |
| | 2402 | Ant1 | No-Hopping | 2348.208 | -54.5 | 2 | 42.76 | Average | 54 | Pass |
| | 2402 | Ant1 | No-Hopping | 2390 | -41.86 | 2 | 55.4 | Peak | 74 | Pass |
| | 2402 | Ant1 | No-Hopping | 2390 | -54.81 | 2 | 42.45 | Average | 54 | Pass |
| | 2480 | Ant1 | No-Hopping | 2483.5 | -40.78 | 2 | 56.48 | Peak | 74 | Pass |
| | 2480 | Ant1 | No-Hopping | 2483.5 | -54.49 | 2 | 42.77 | Average | 54 | Pass |
| | 2480 | Ant1 | No-Hopping | 2499.28 | -39.44 | 2 | 57.82 | Peak | 74 | Pass |
| | 2480 | Ant1 | No-Hopping | 2490.424 | -54.36 | 2 | 42.9 | Average | 54 | Pass |
| | 2480 | Ant1 | No-Hopping | 2500 | -41.51 | 2 | 55.75 | Peak | 74 | Pass |
| | 2480 | Ant1 | No-Hopping | 2500 | -54.61 | 2 | 42.65 | Average | 54 | Pass |
| | 2402 | Ant1 | No-Hopping | 2310 | -41.74 | 2 | 55.52 | Peak | 74 | Pass |
| | 2402 | Ant1 | No-Hopping | 2310 | -55.27 | 2 | 41.99 | Average | 54 | Pass |
| | 2402 | Ant1 | No-Hopping | 2355.408 | -40.25 | 2 | 57.01 | Peak | 74 | Pass |
| | 2402 | Ant1 | No-Hopping | 2362.32 | -54.38 | 2 | 42.88 | Average | 54 | Pass |
| | 2402 | Ant1 | No-Hopping | 2390 | -42.78 | 2 | 54.48 | Peak | 74 | Pass |
| | 2402 | Ant1 | No-Hopping | 2390 | -54.67 | 2 | 42.59 | Average | 54 | Pass |
| | 2480 | Ant1 | No-Hopping | 2483.5 | -41.6 | 2 | 55.66 | Peak | 74 | Pass |
| | 2480 | Ant1 | No-Hopping | 2483.5 | -54.52 | 2 | 42.74 | Average | 54 | Pass |
| | 2480 | Ant1 | No-Hopping | 2495.896 | -38.82 | 2 | 58.44 | Peak | 74 | Pass |
| | 2480 | Ant1 | No-Hopping | 2497.408 | -54.32 | 2 | 42.94 | Average | 54 | Pass |
| | 2480 | Ant1 | No-Hopping | 2500 | -41.22 | 2 | 56.04 | Peak | 74 | Pass |
| | 2480 | Ant1 | No-Hopping | 2500 | -54.62 | 2 | 42.64 | Average | 54 | Pass |

Test Graphs

Restrict Band NVNT 1-DH1 2402MHz Ant1 No-Hopping Peak

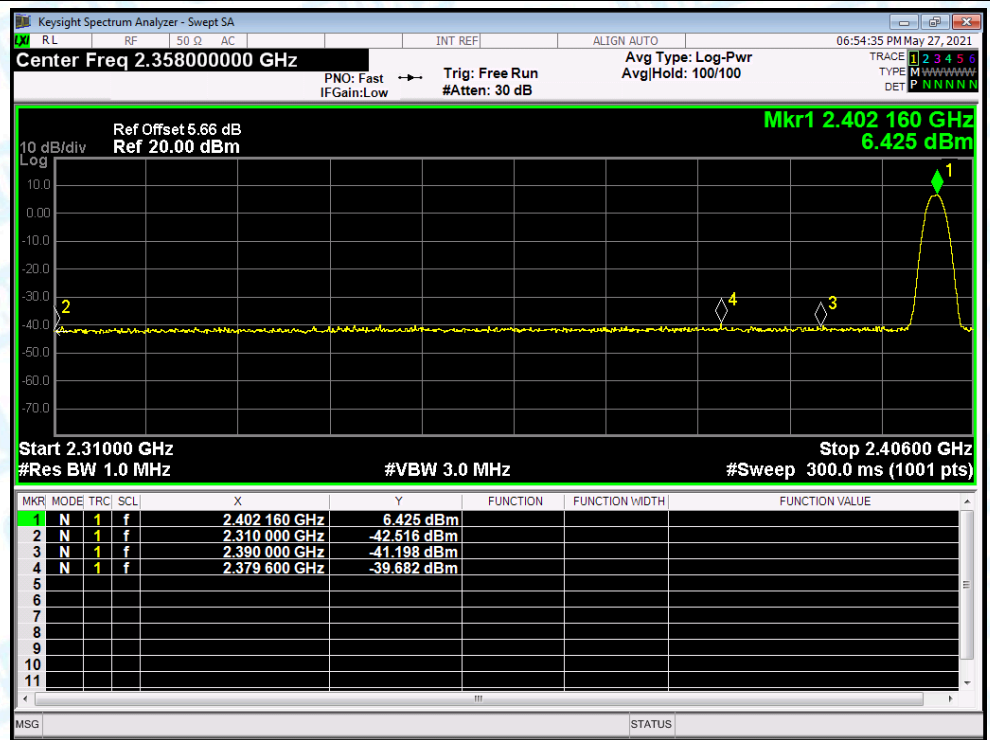

Restrict Band NVNT 1-DH1 2402MHz Ant1 No-Hopping Average

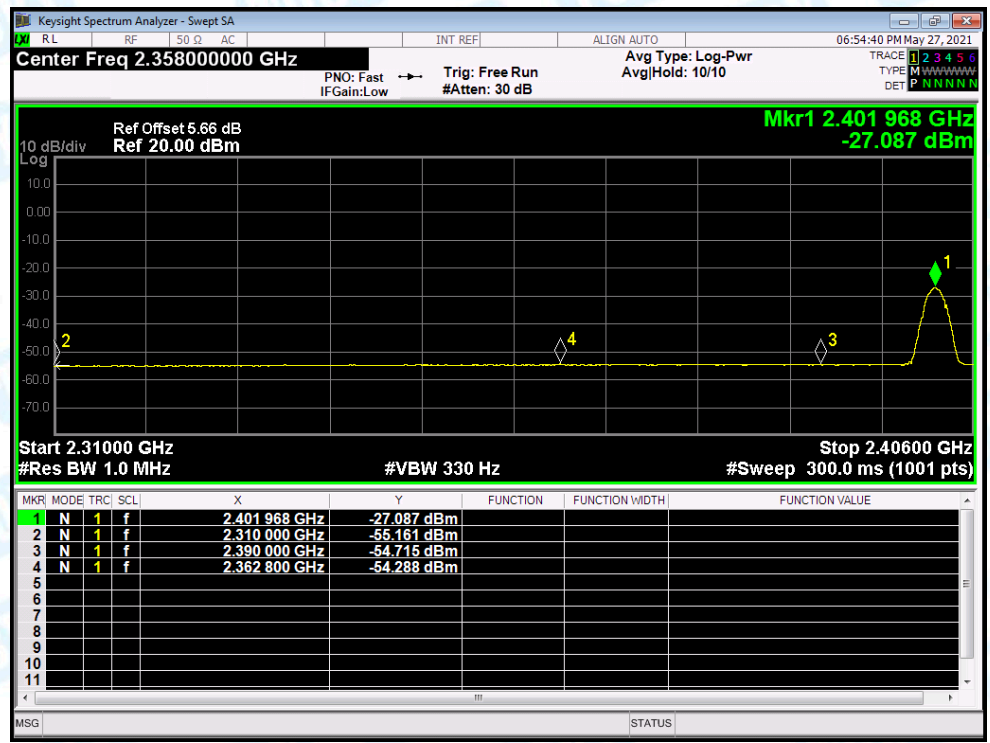

Restrict Band NVNT 1-DH1 2480MHz Ant1 No-Hopping Peak

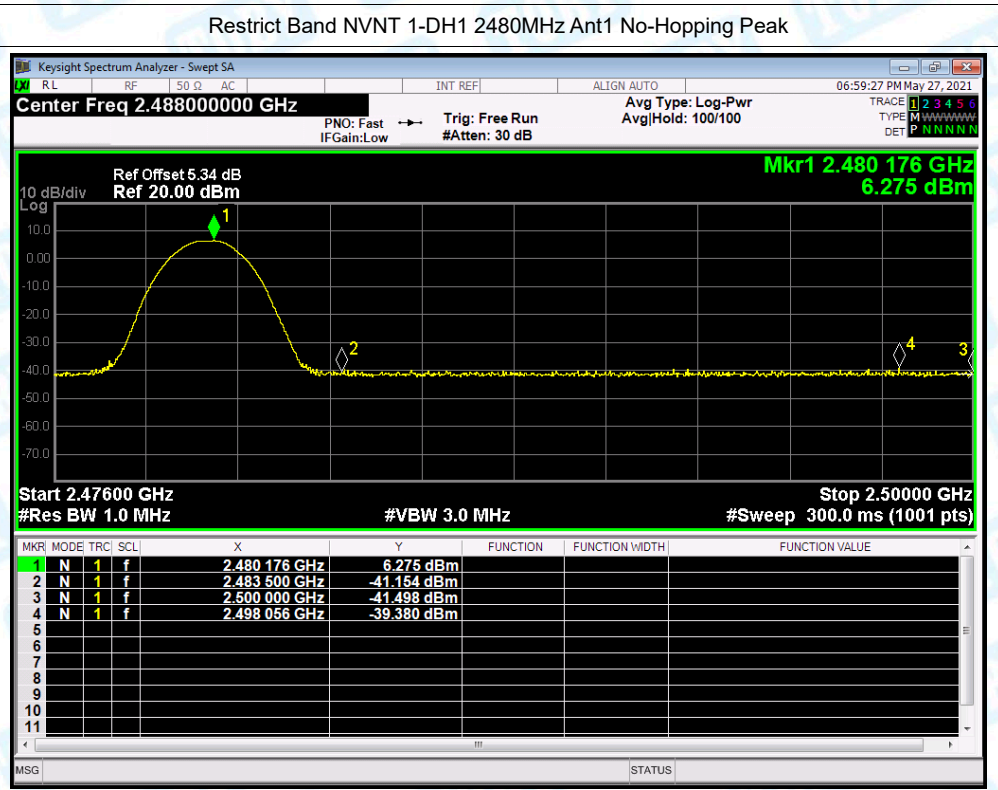

Restrict Band NVNT 1-DH1 2480MHz Ant1 No-Hopping Average

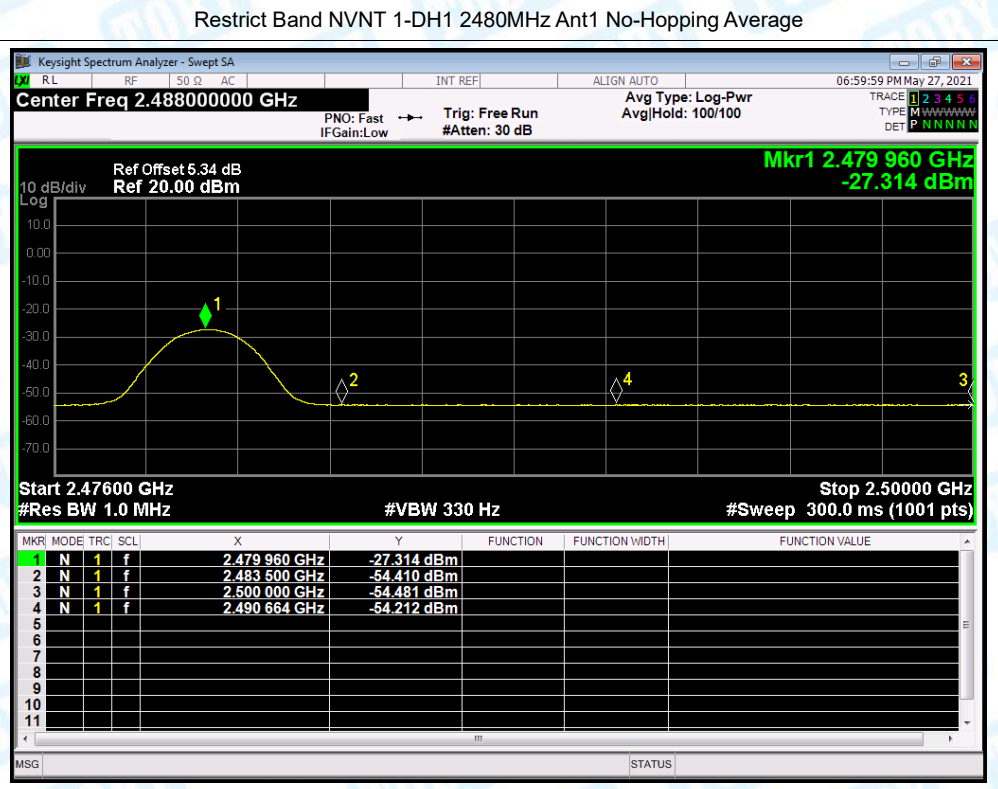

Restrict Band NVNT 2-DH1 2402MHz Ant1 No-Hopping Peak

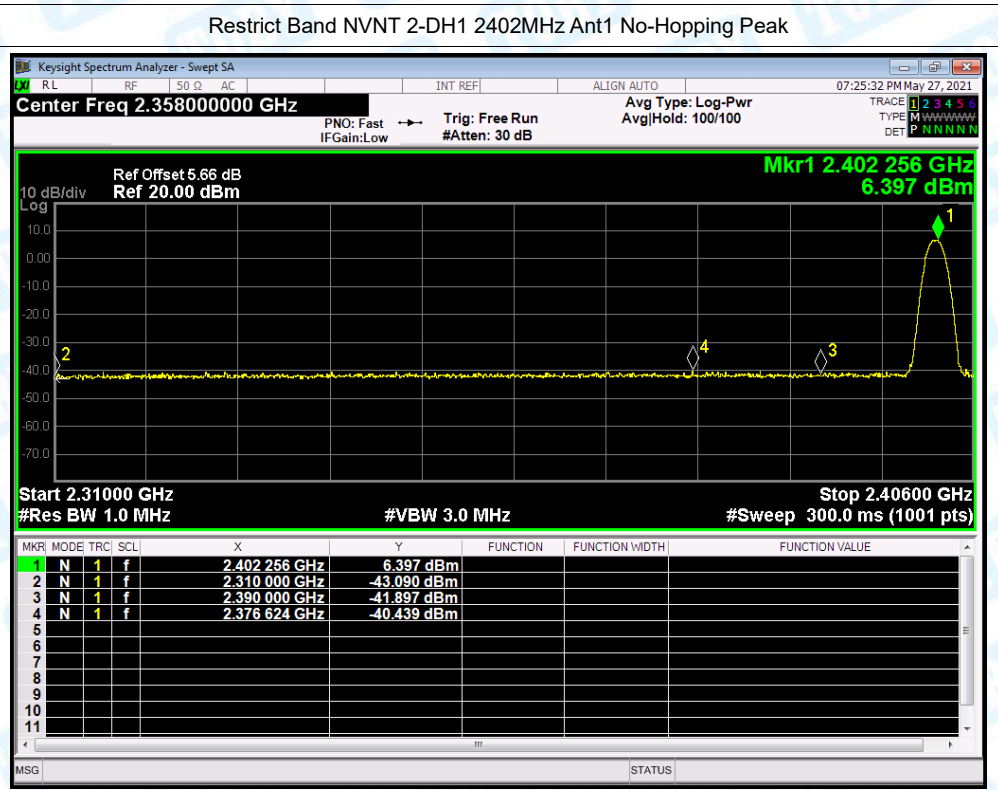

Restrict Band NVNT 2-DH1 2402MHz Ant1 No-Hopping Average

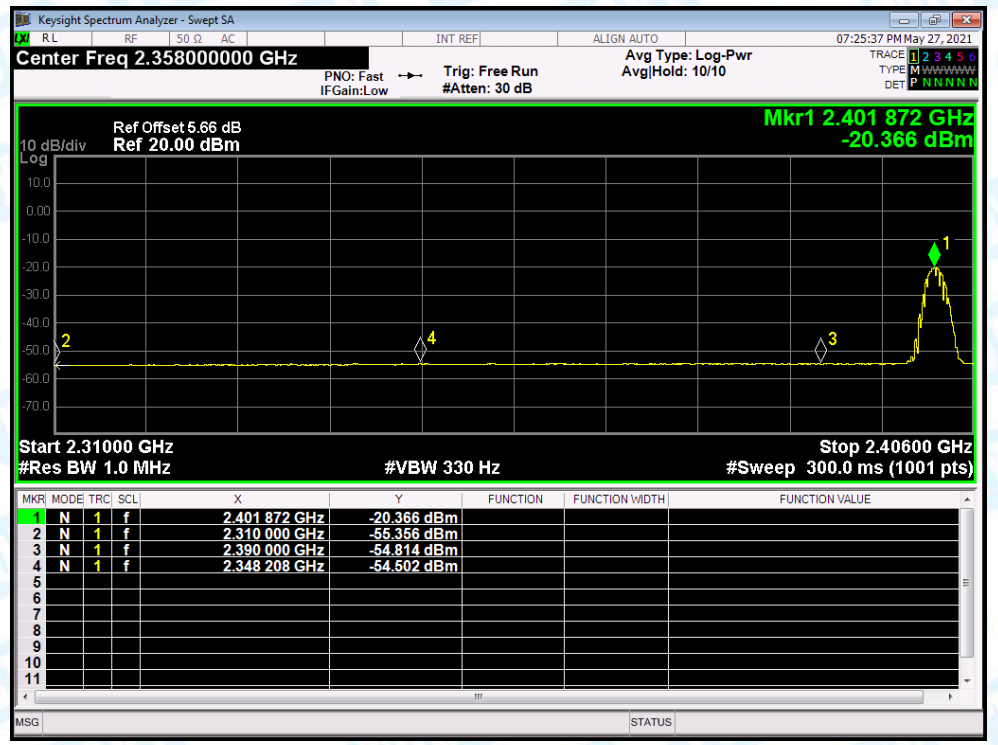

Restrict Band NVNT 2-DH1 2480MHz Ant1 No-Hopping Peak

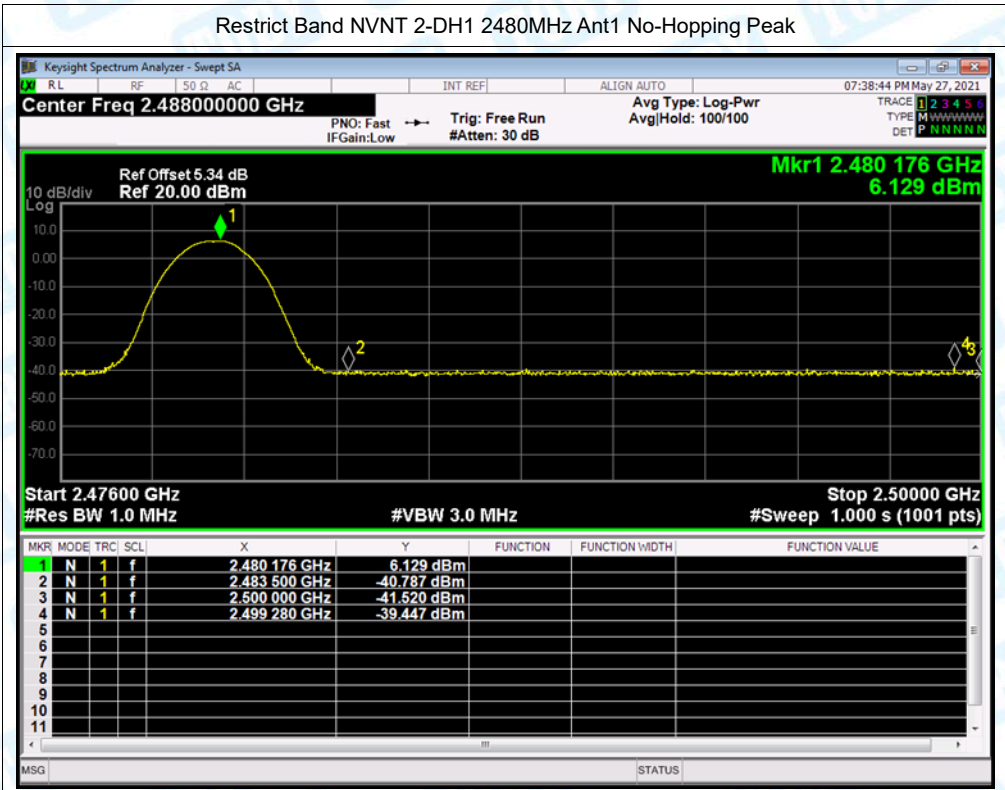

Restrict Band NVNT 2-DH1 2480MHz Ant1 No-Hopping Average

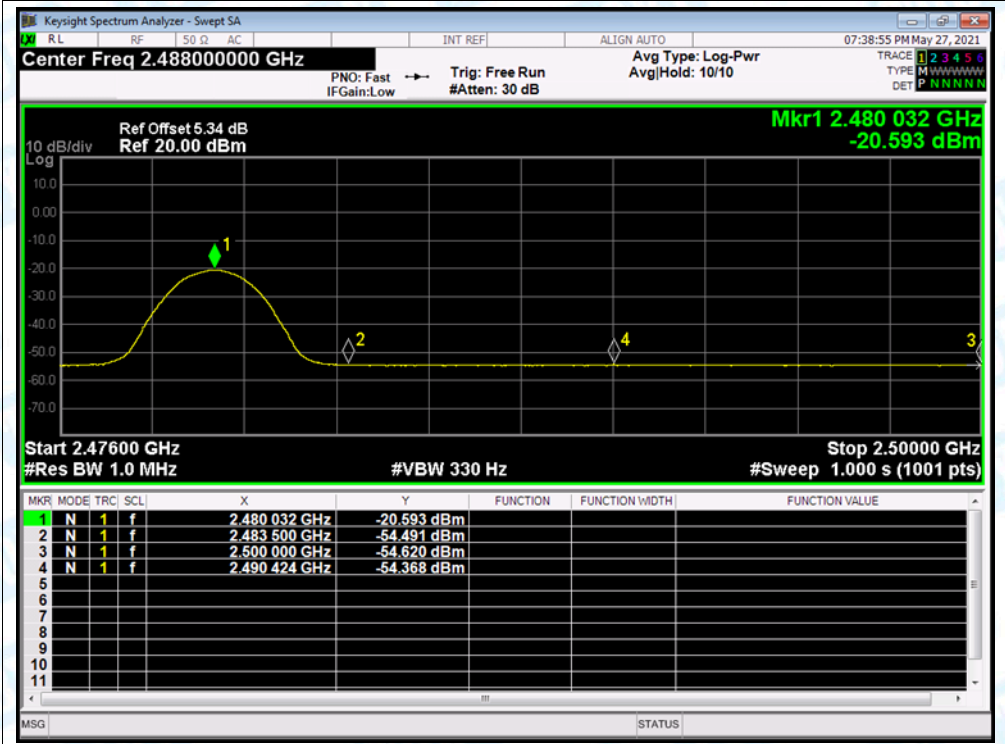

Restrict Band NVNT 3-DH1 2402MHz Ant1 No-Hopping Peak

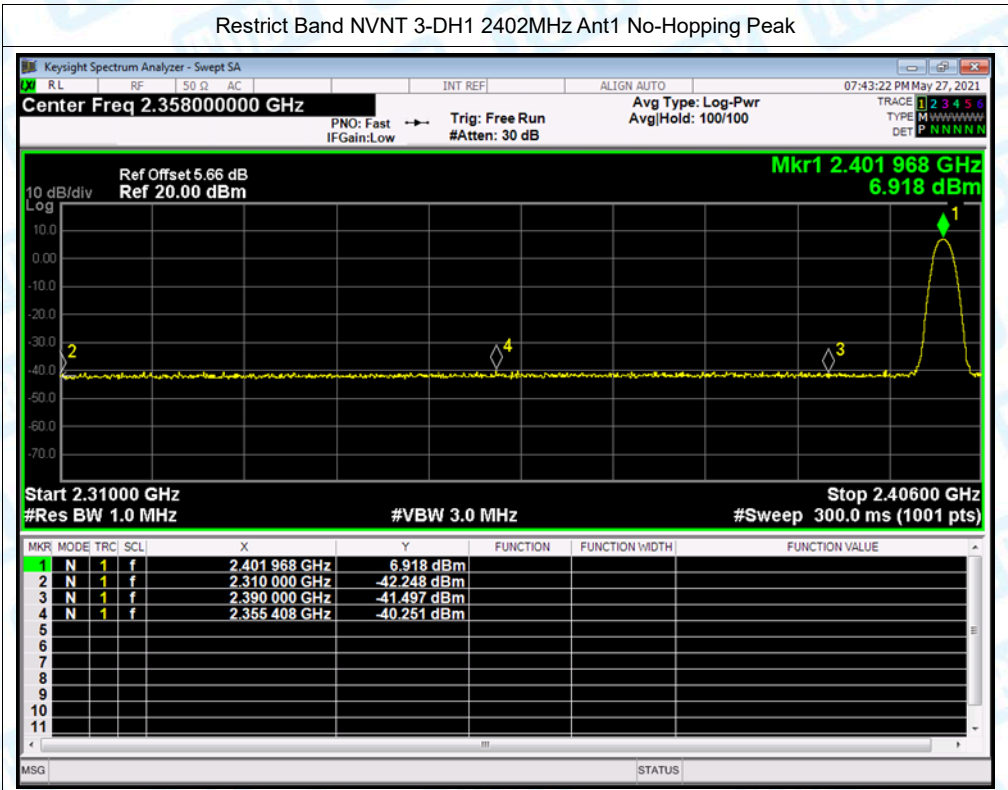

Restrict Band NVNT 3-DH1 2402MHz Ant1 No-Hopping Average

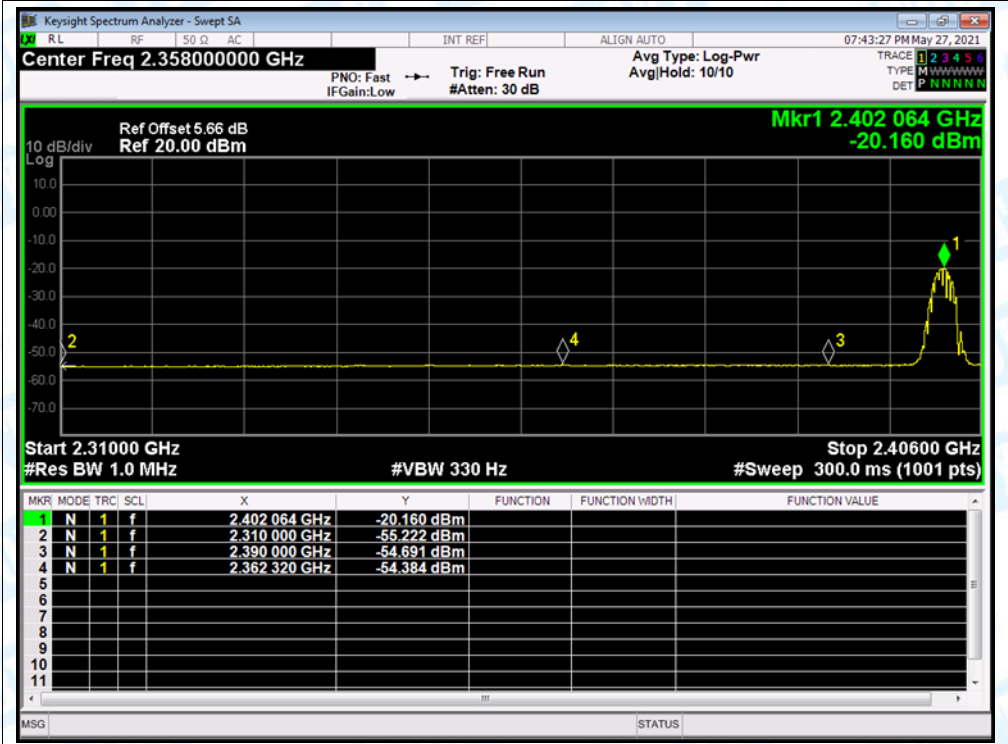

Restrict Band NVNT 3-DH1 2480MHz Ant1 No-Hopping Peak

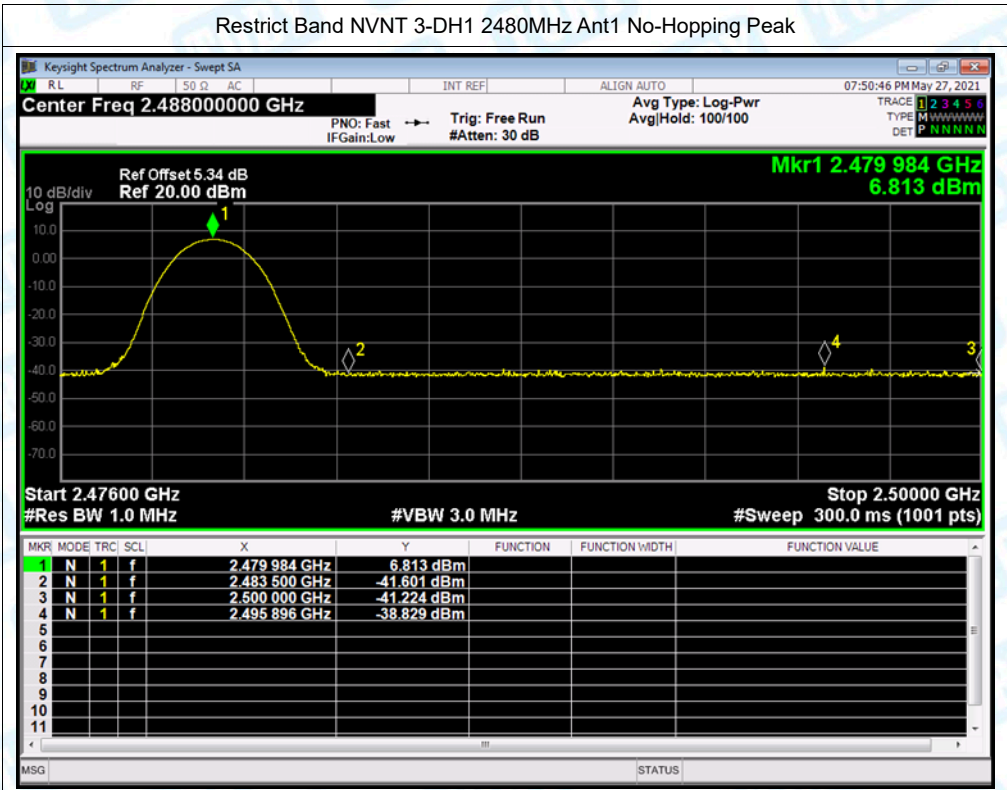

Restrict Band NVNT 3-DH1 2480MHz Ant1 No-Hopping Average

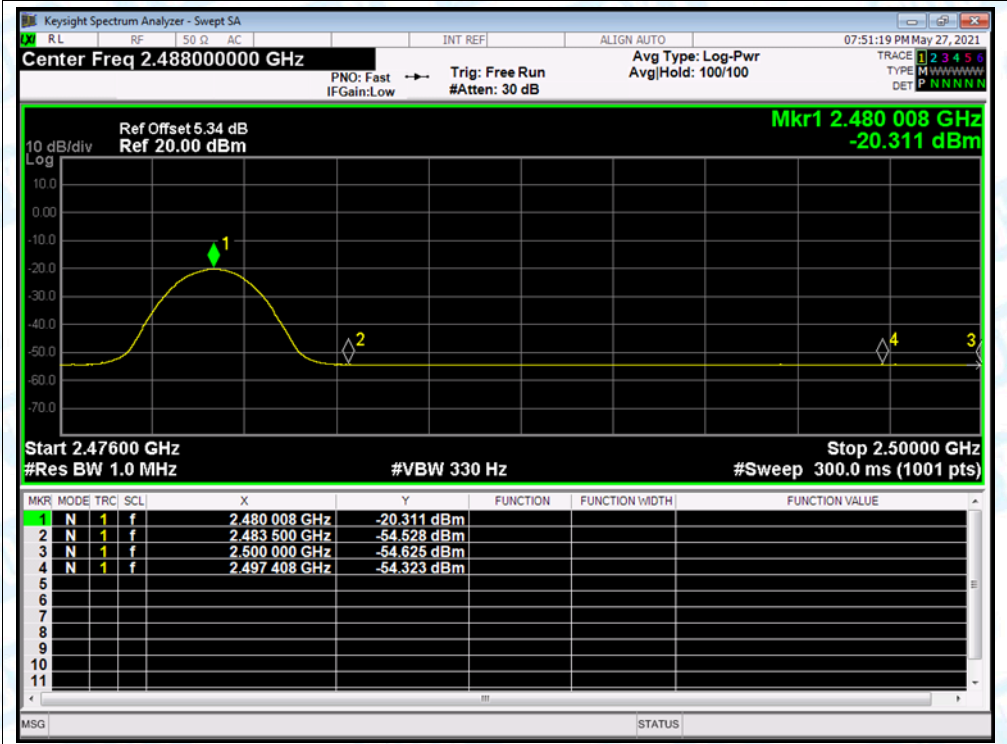

Attachment D-- Conducted Spurious Emissions and Band Edges Test

| | | | |
|---------------|-------------------------------|--------------------|-----|
| Temperature: | 25°C | Relative Humidity: | 55% |
| Test Voltage: | AC 120V/60 Hz | | |
| Test Mode: | TX GFSK Mode 2402MHz/2480 MHz | | |
| Remark: | Only worse case is reported | | |

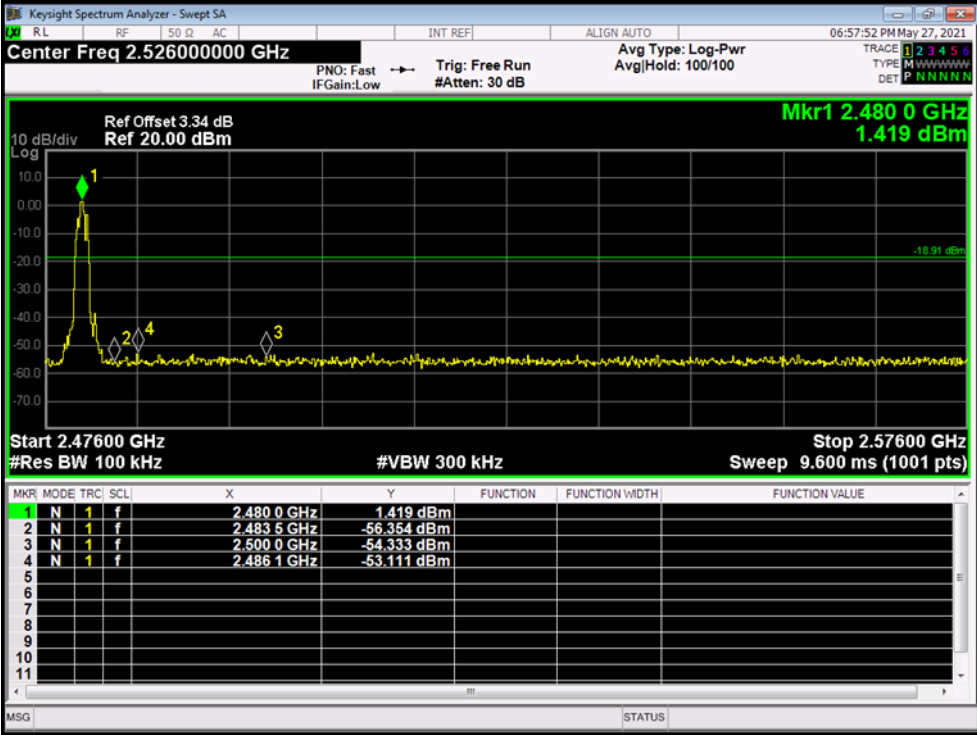
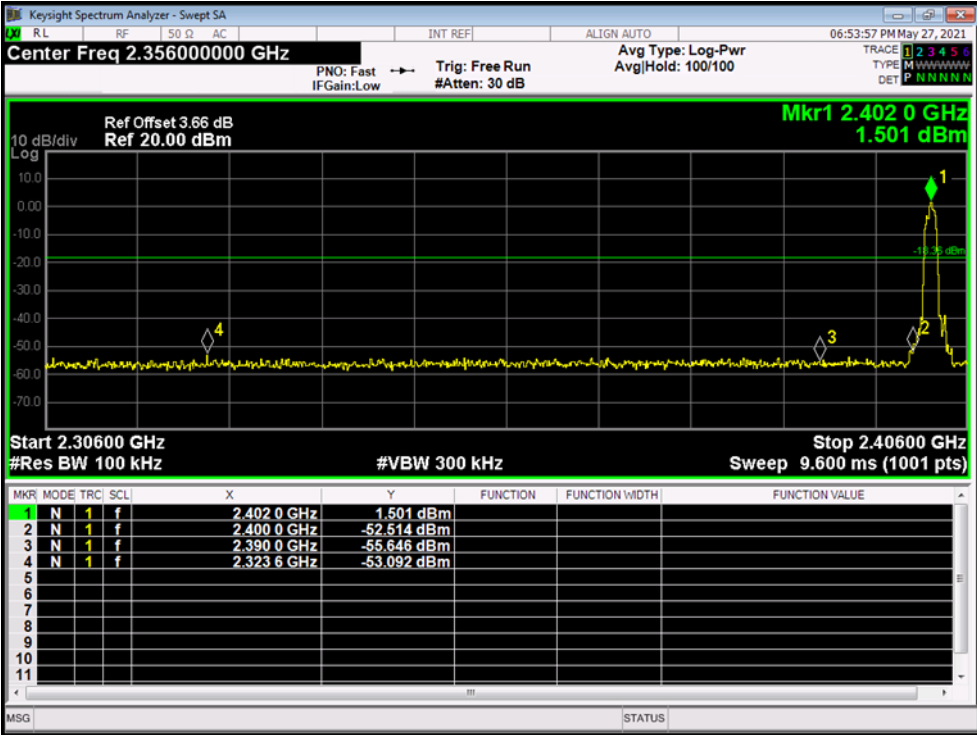

| | | | |
|---------------|-----------------------------|--------------------|-----|
| Temperature: | 25°C | Relative Humidity: | 55% |
| Test Voltage: | AC 120V/60 Hz | | |
| Test Mode: | GFSK Hopping Mode | | |
| Remark: | Only worse case is reported | | |

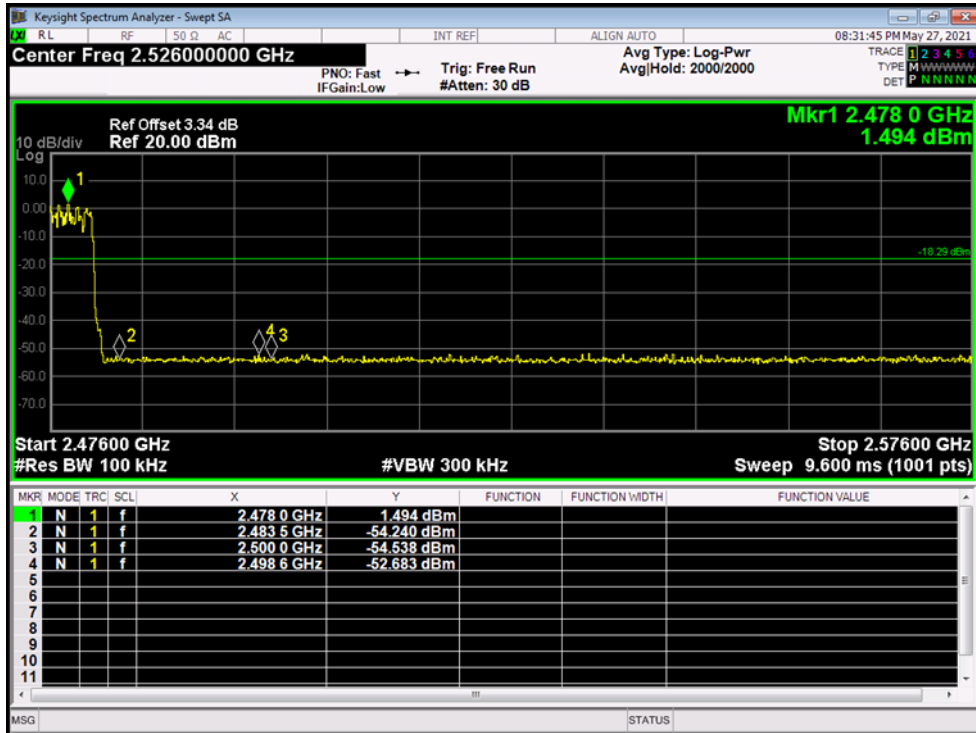
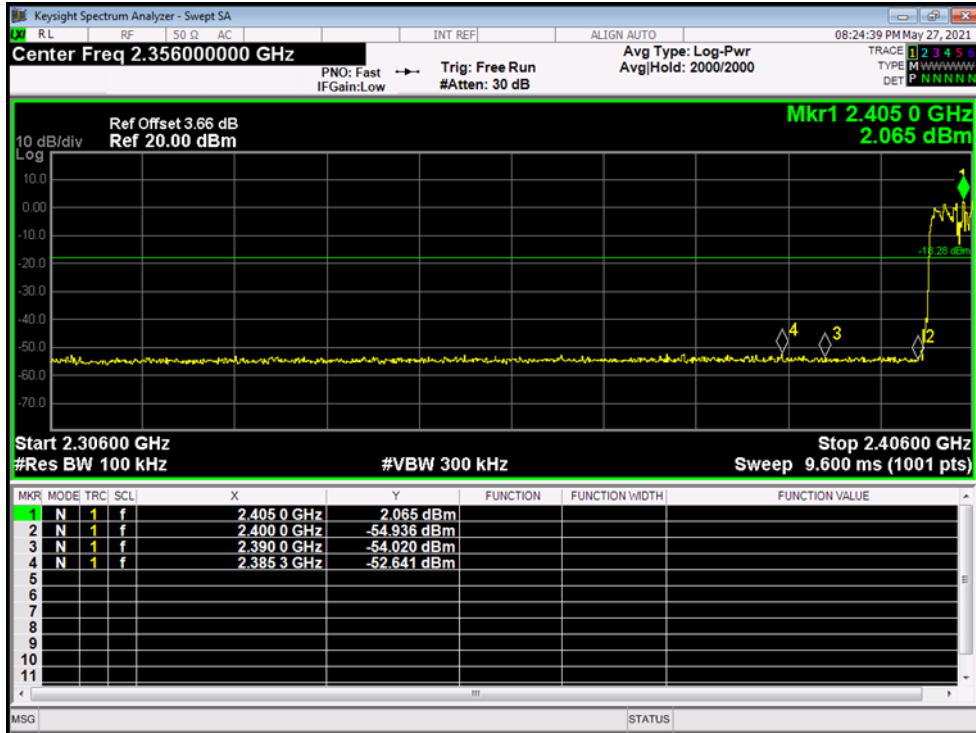

| | | | |
|---------------|---|--------------------|-----|
| Temperature: | 25°C | Relative Humidity: | 55% |
| Test Voltage: | AC 120V/60 Hz | | |
| Test Mode: | TX π /4-DQPSK Mode 2402MHz/2480 MHz | | |
| Remark: | Only worse case is reported | | |

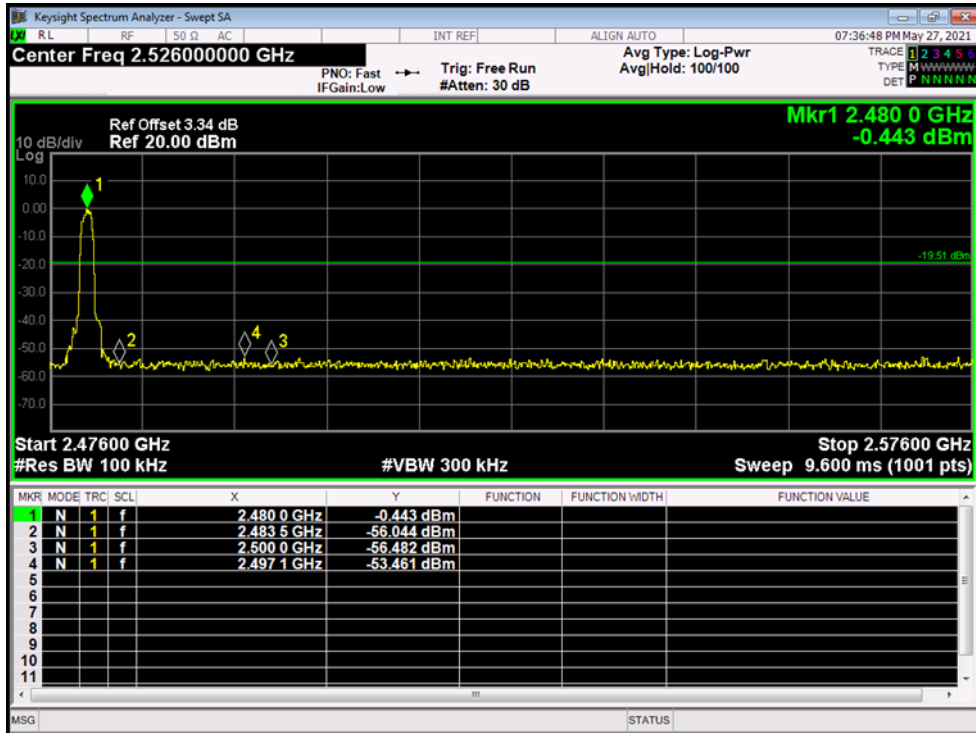
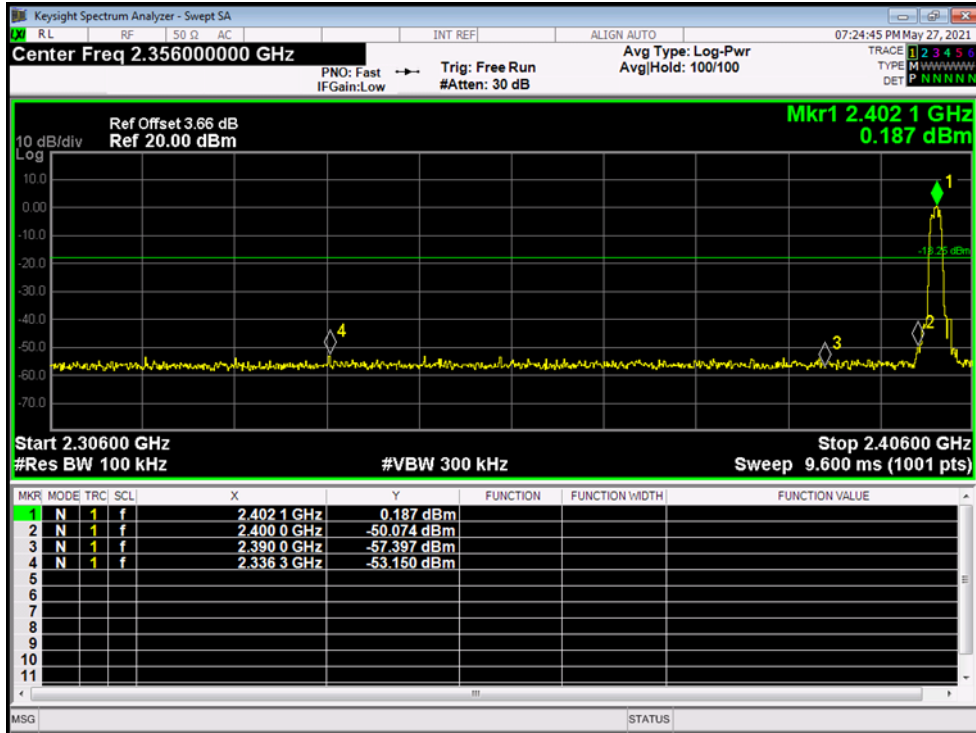

| | | | |
|---------------|-----------------------------|--------------------|-----|
| Temperature: | 25°C | Relative Humidity: | 55% |
| Test Voltage: | AC 120V/60 Hz | | |
| Test Mode: | π /4-DQPSK Hopping Mode | | |
| Remark: | Only worse case is reported | | |

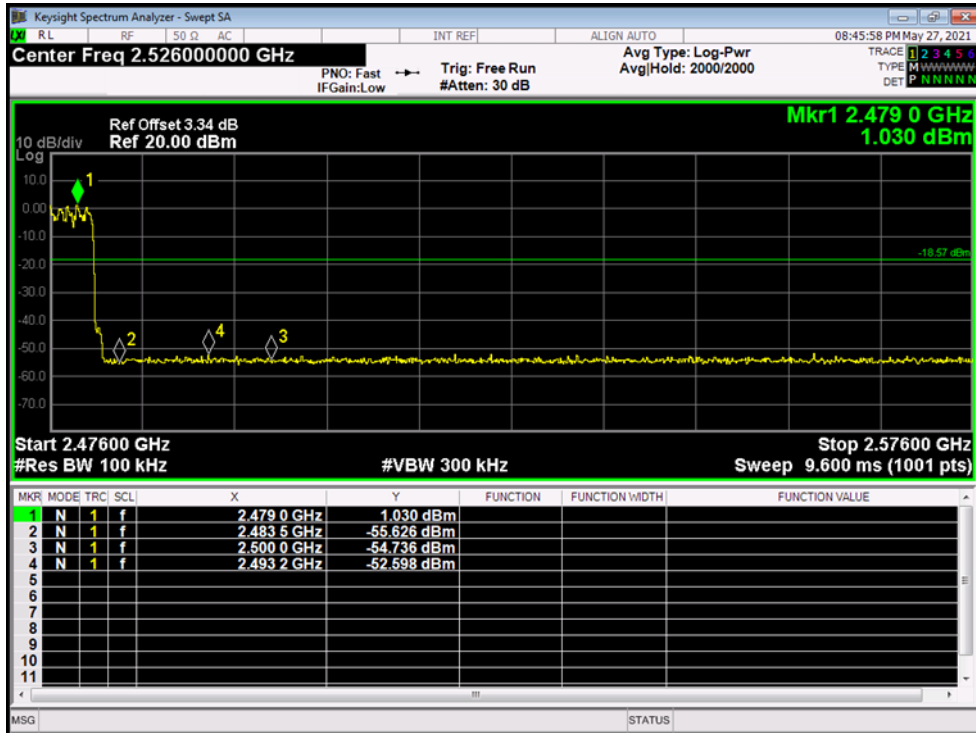
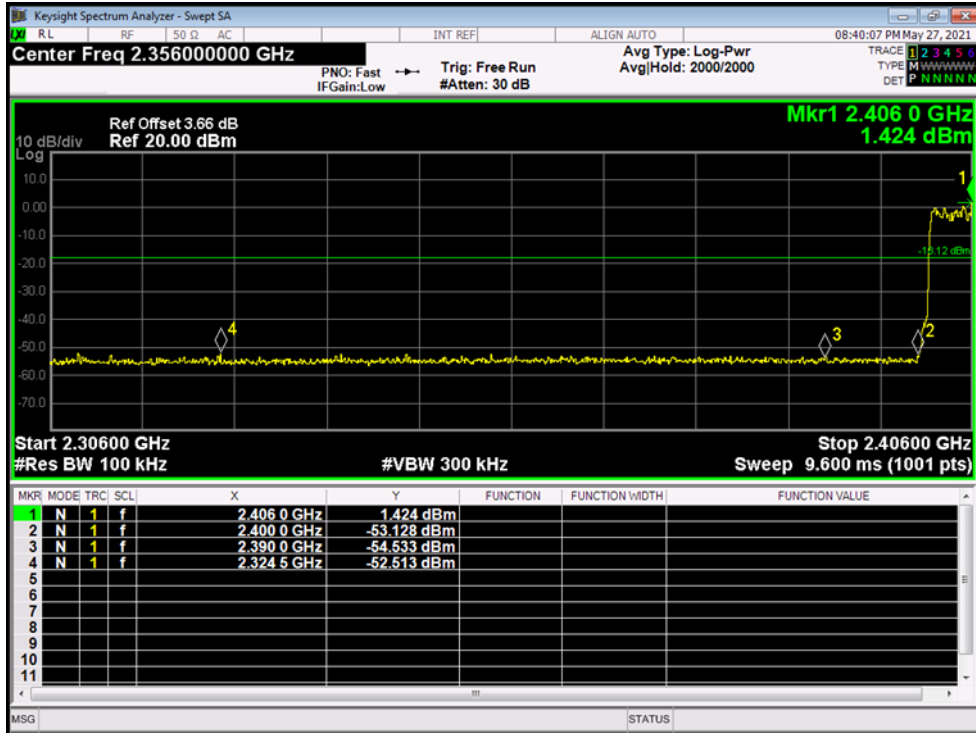

| | | | |
|---------------|--------------------------------|--------------------|-----|
| Temperature: | 25°C | Relative Humidity: | 55% |
| Test Voltage: | AC 120V/60 Hz | | |
| Test Mode: | TX 8DPSK Mode 2402MHz/2480 MHz | | |
| Remark: | Only worse case is reported | | |

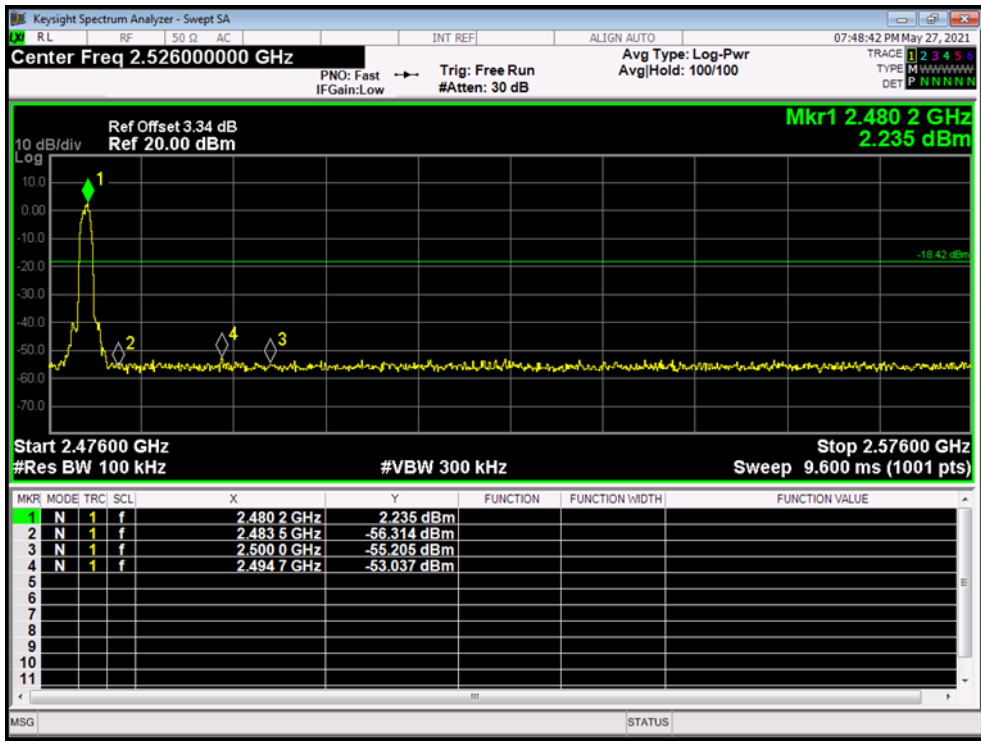
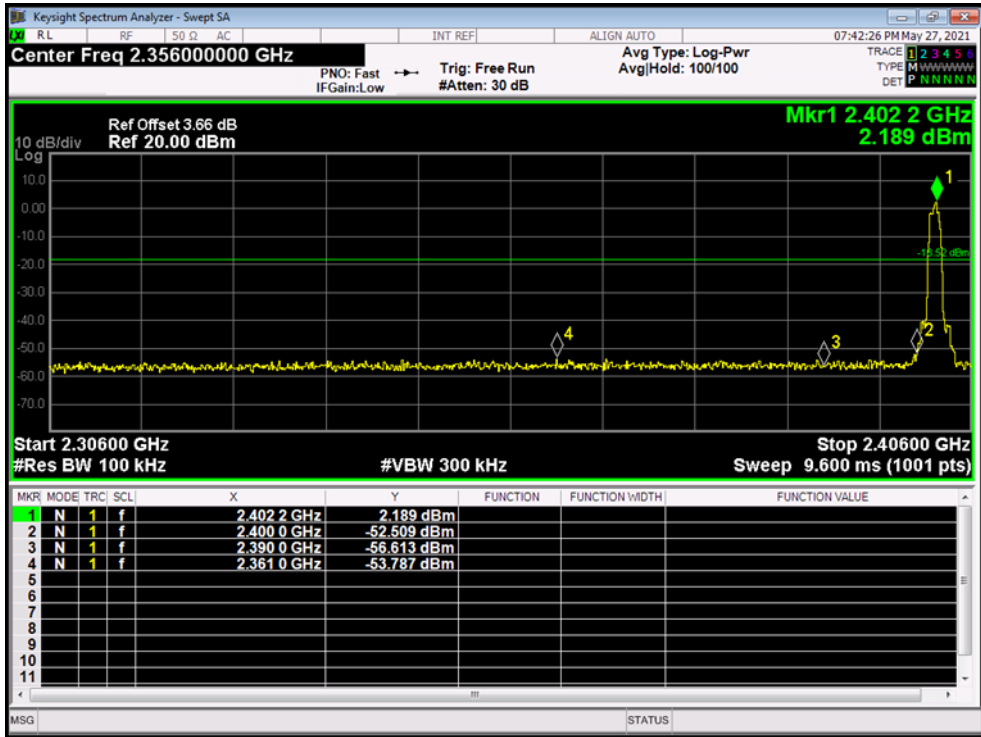

| | | | |
|---------------|-----------------------------|--------------------|-----|
| Temperature: | 25°C | Relative Humidity: | 55% |
| Test Voltage: | AC 120V/60 Hz | | |
| Test Mode: | 8DPSK Hopping Mode | | |
| Remark: | Only worse case is reported | | |

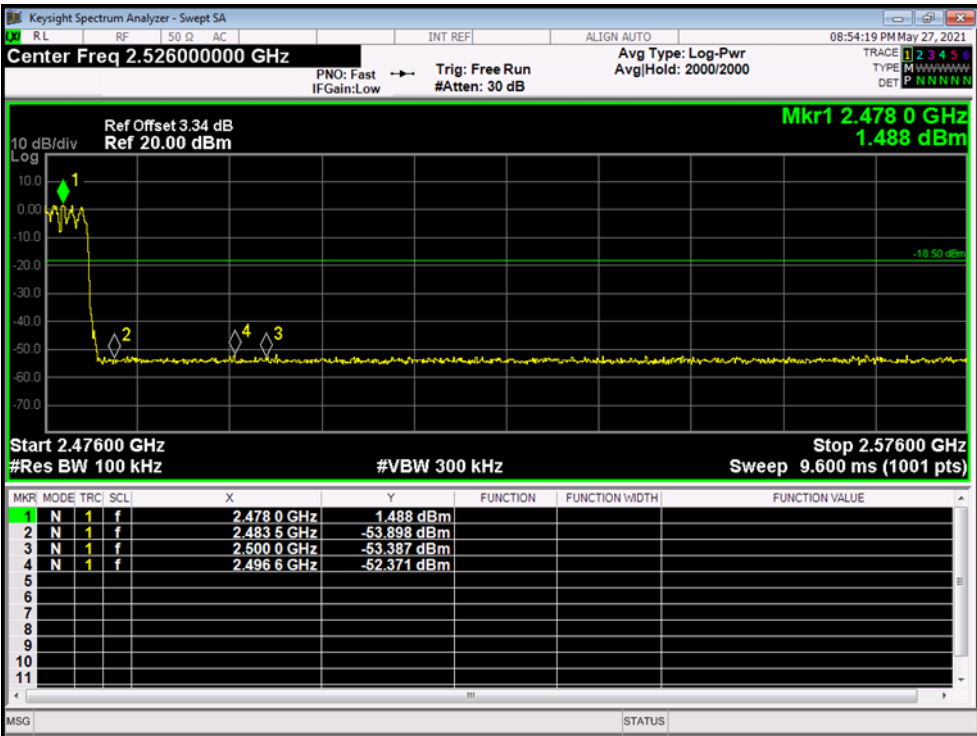
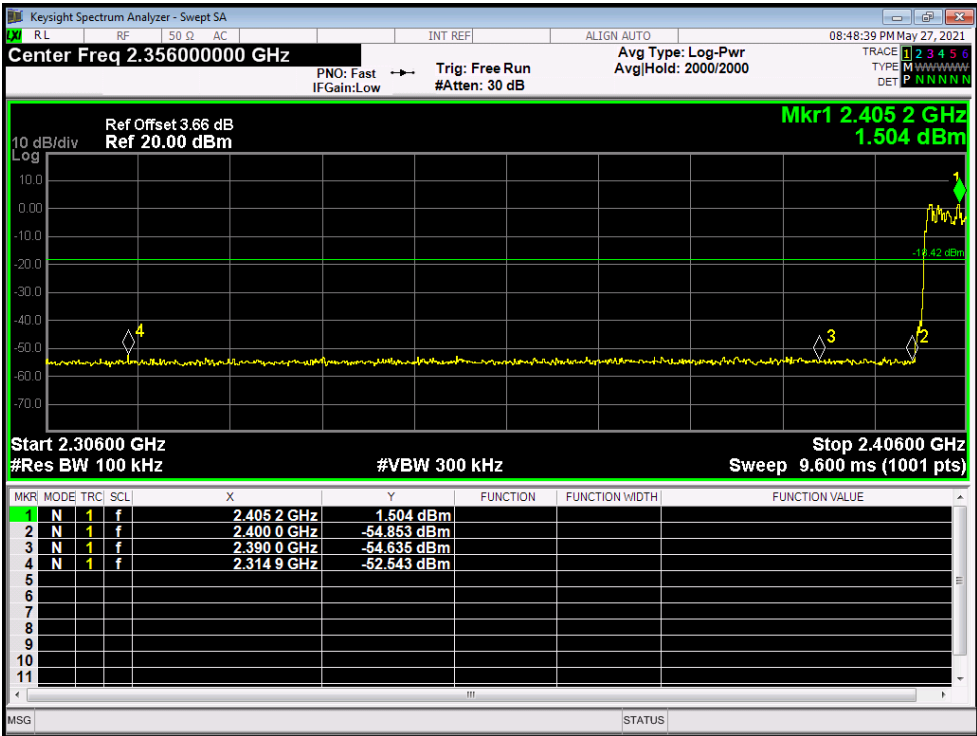

RF Conducted Spurious Emissions

| Temperature: | 25°C | Relative Humidity: | 55% | | |
|---------------|---|--------------------|-----------------|-------------|---------|
| Test Voltage: | AC 120V/60 Hz | | | | |
| Mode | Frequency (MHz) | Antenna | Max Value (dBc) | Limit (dBc) | Verdict |
| GFSK | 2402 | Ant1 | -48.45 | -20 | Pass |
| GFSK | 2442 | Ant1 | -49.47 | -20 | Pass |
| GFSK | 2480 | Ant1 | -48.63 | -20 | Pass |
| Remark: | The EUT is programmed in continuously transmitting mode | | | | |

GFSK Mode

2402 MHz

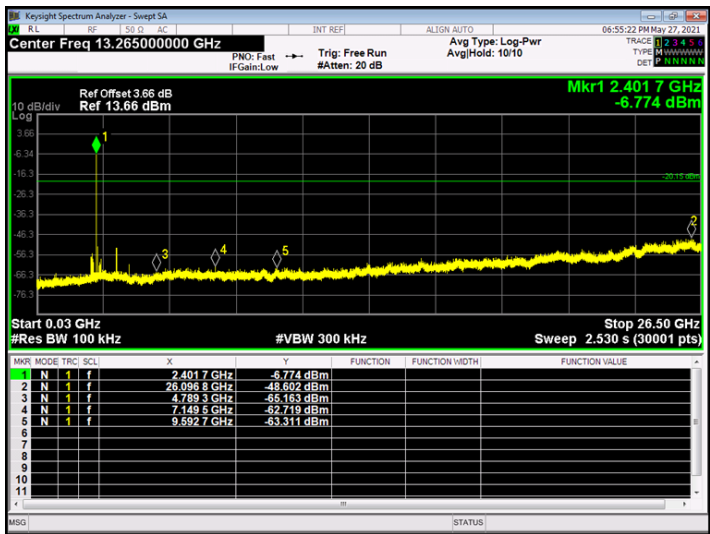
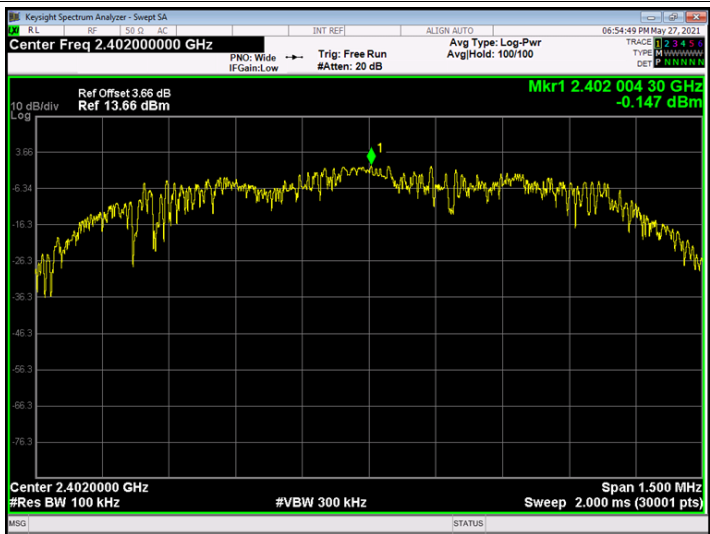

GFSK Mode

2441 MHz

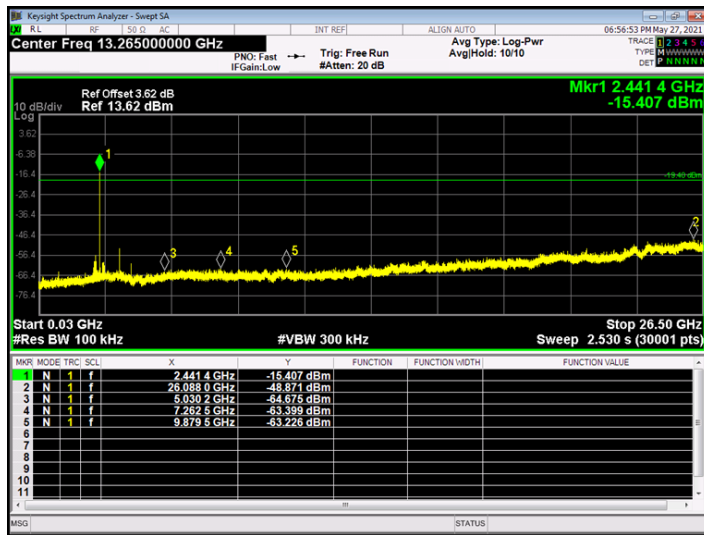
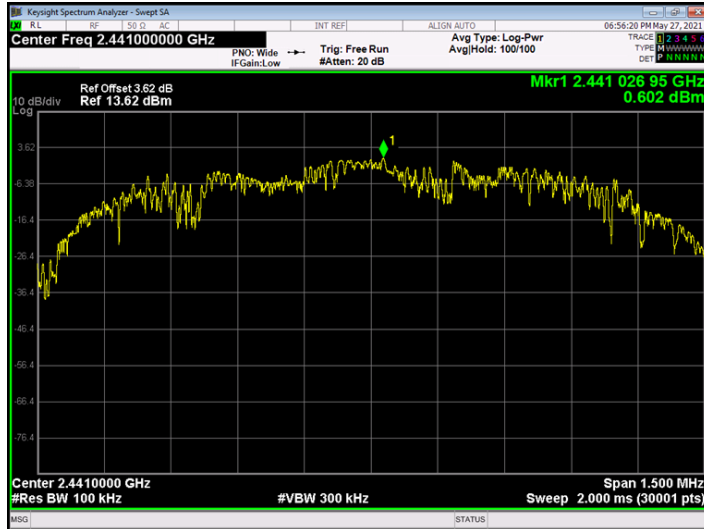

GFSK Mode

2480 MHz

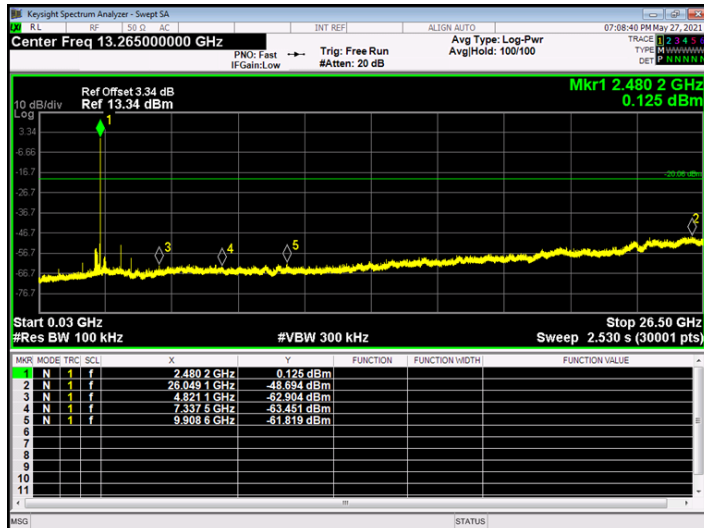
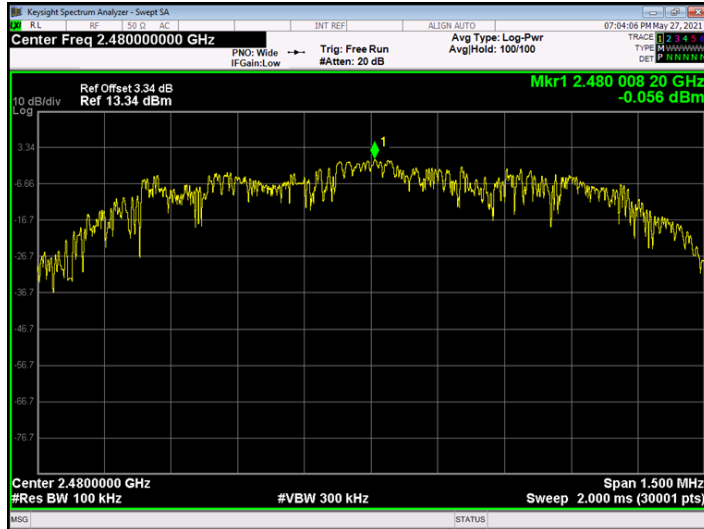

| | | | | | |
|----------------------|---|---------------------------|------------------------|--------------------|----------------|
| Temperature: | 25°C | Relative Humidity: | 55% | | |
| Test Voltage: | AC 120V/60 Hz | | | | |
| Mode | Frequency (MHz) | Antenna | Max Value (dBc) | Limit (dBc) | Verdict |
| π /4-DQPSK | 2402 | Ant1 | -48.95 | -20 | Pass |
| π /4-DQPSK | 2442 | Ant1 | -49.52 | -20 | Pass |
| π /4-DQPSK | 2480 | Ant1 | -48.35 | -20 | Pass |
| Remark: | The EUT is programmed in continuously transmitting mode | | | | |

π /4-DQPSK Mode

2402 MHz

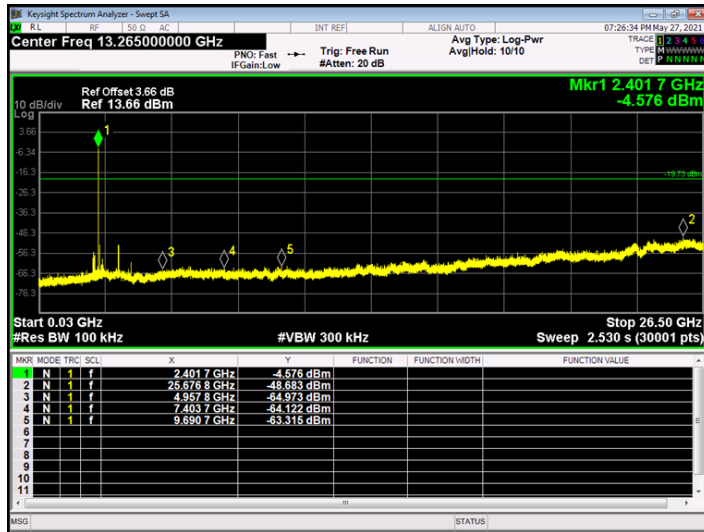
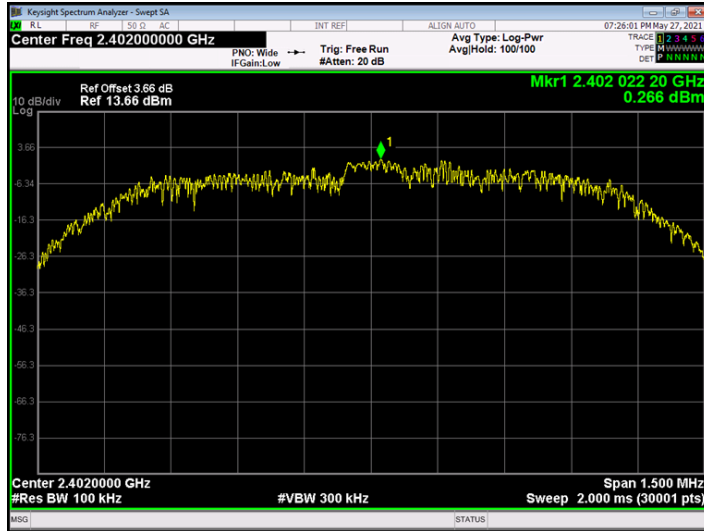

π /4-QPSK Mode

2441 MHz

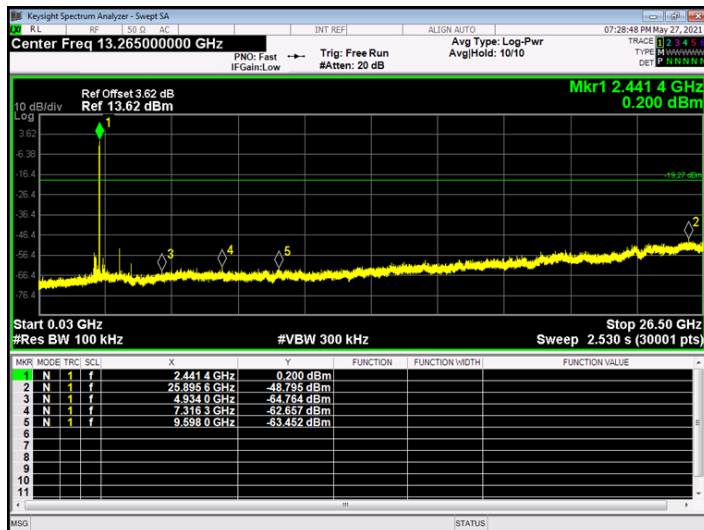
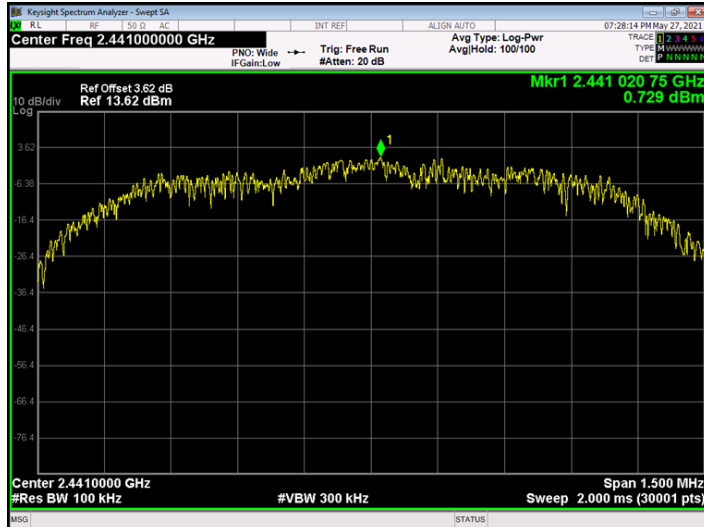

π /4-DQPSK Mode

2480 MHz

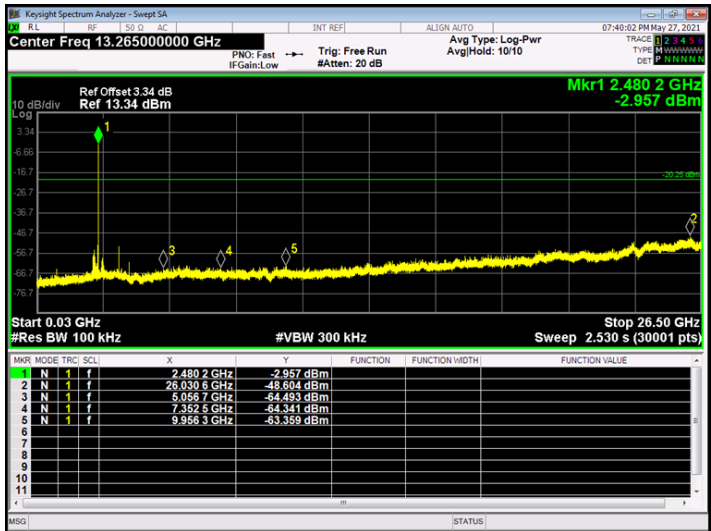
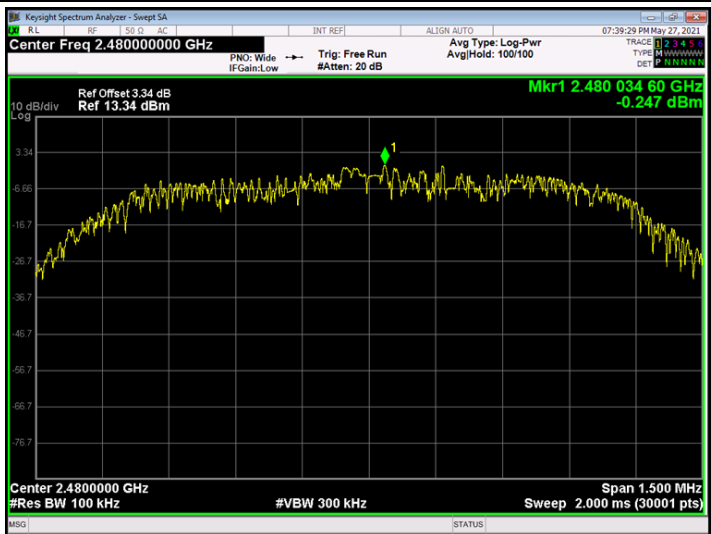

| | | | | | |
|----------------------|---|---------------------------|------------------------|--------------------|----------------|
| Temperature: | 25°C | Relative Humidity: | 55% | | |
| Test Voltage: | AC 120V/60 Hz | | | | |
| Mode | Frequency (MHz) | Antenna | Max Value (dBc) | Limit (dBc) | Verdict |
| 8DPSK | 2402 | Ant1 | -49.02 | -20 | Pass |
| 8DPSK | 2442 | Ant1 | -49.9 | -20 | Pass |
| 8DPSK | 2480 | Ant1 | -49.5 | -20 | Pass |
| Remark: | The EUT is programmed in continuously transmitting mode | | | | |

8DPSK Mode

2402 MHz

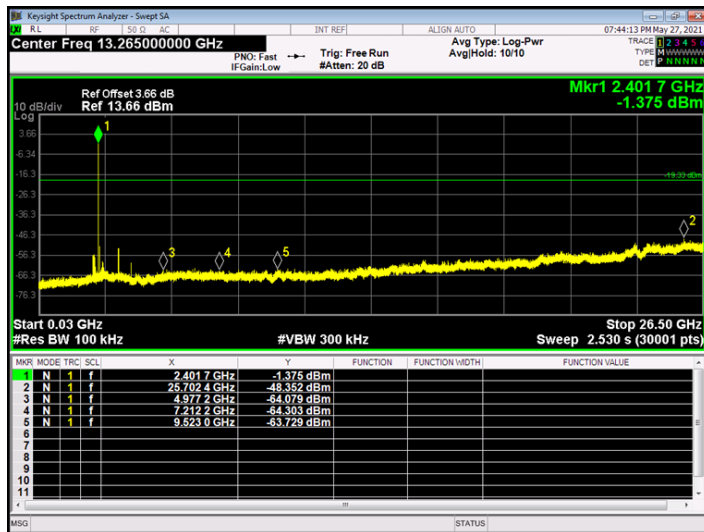
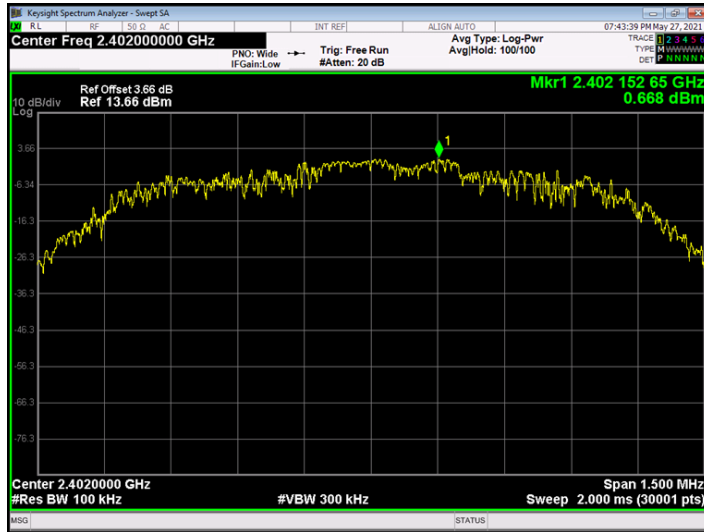

8DPSK Mode

2441 MHz

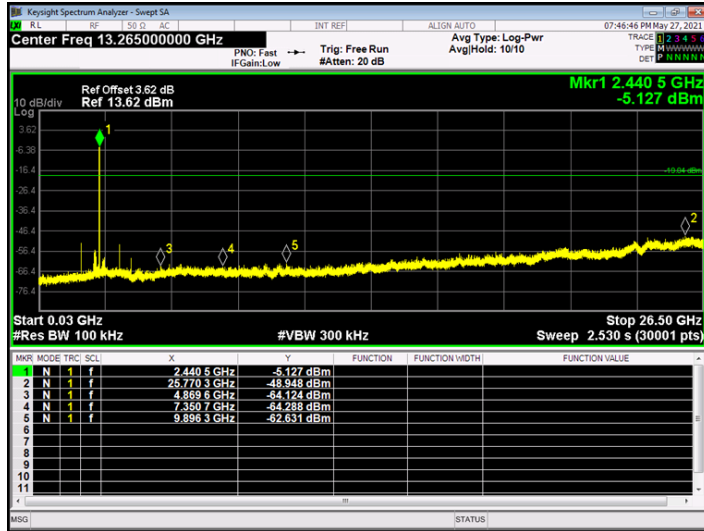
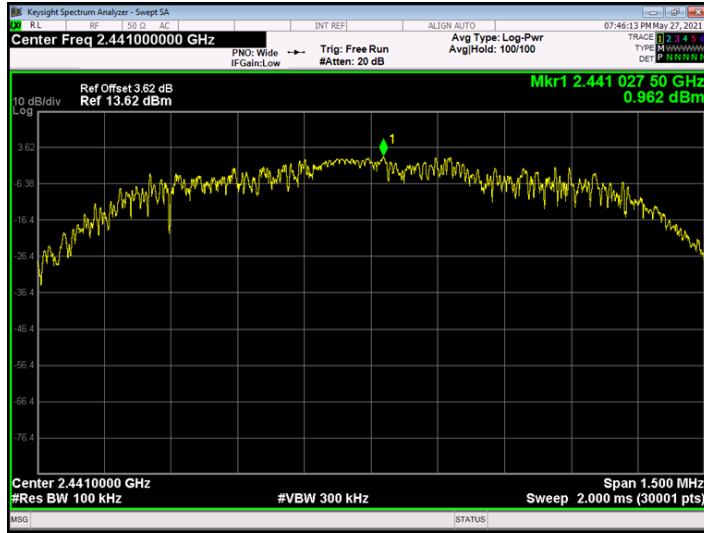

8DPSK Mode

2480 MHz

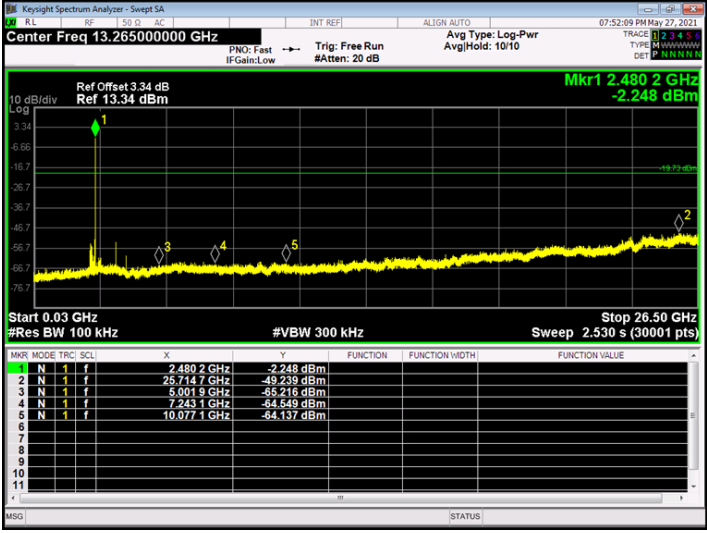
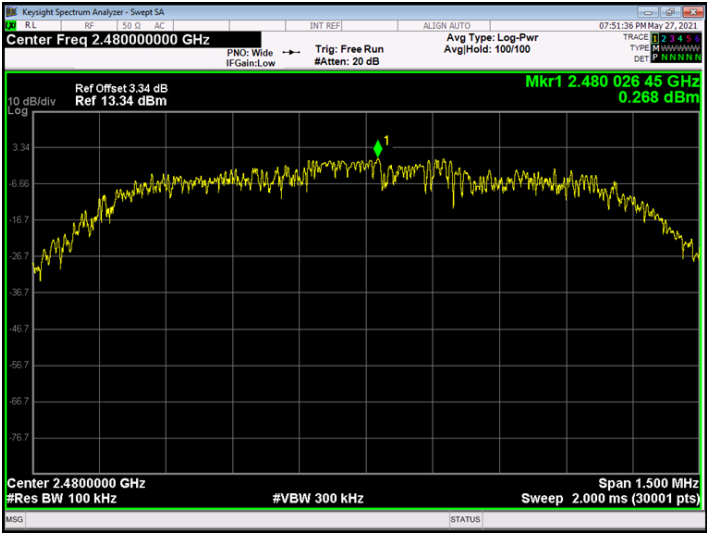

Attachment E-- Number of Hopping Channel Test Data

| Temperature: | 25°C | Relative Humidity: | 55% |
|-----------------|----------------|-----------------------------|-------|
| Test Voltage: | AC 120V/60 Hz | | |
| Test Mode: | Hopping Mode | | |
| Frequency Range | Test Mode | Quantity of Hopping Channel | Limit |
| 2402MHz~2480MHz | GFSK | 79 | >15 |
| | π /4-DQPSK | 79 | |
| | 8DPSK | 79 | |

GFSK Mode

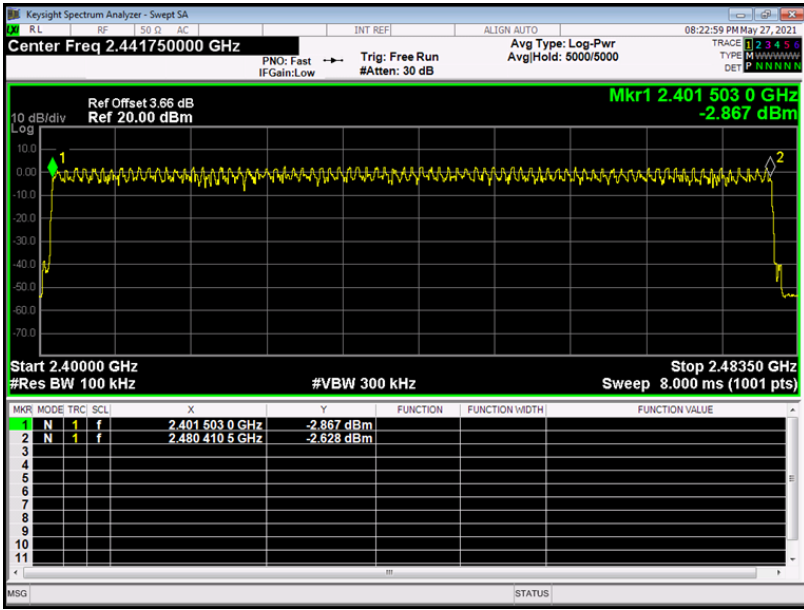

π /4-DQPSK Mode

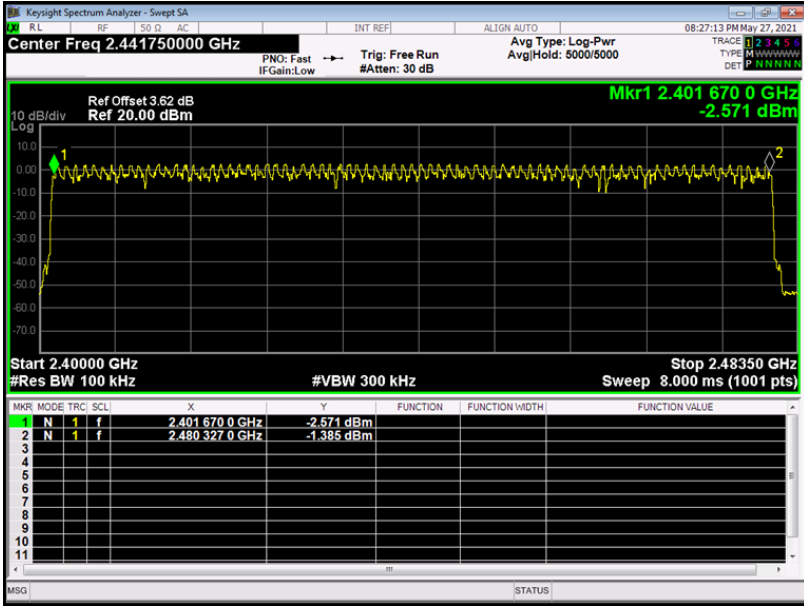

8DPSK Mode

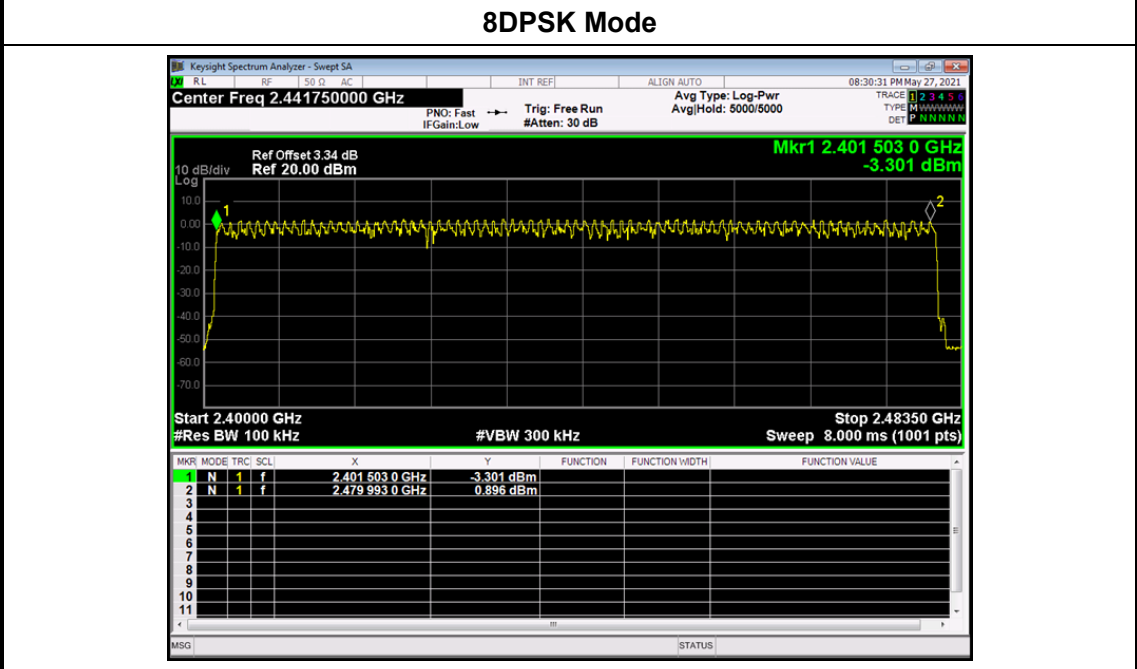

Attachment F-- Average Time of Occupancy Test Data

| Temperature: | | 25°C | | Relative Humidity: | | 55% | |
|----------------------|---------------|---------------------|---------------------|---------------------------|------------|--------|--|
| Test Voltage: | | AC 120V/60 Hz | | | | | |
| Test Mode: | | Hopping Mode (GFSK) | | | | | |
| Test Mode | Channel (MHz) | Pulse Time (ms) | Total of Dwell (ms) | Period Time (s) | Limit (ms) | Result | |
| 1DH1 | 2441 | 0.281 | 89.92 | 31.60 | 400 | PASS | |
| 1DH3 | 2441 | 1.632 | 261.12 | 31.60 | 400 | PASS | |
| 1DH5 | 2441 | 2.879 | 307.093 | 31.60 | 400 | PASS | |

1DH1 Total of Dwell= Pulse Time*(1600/2)*31.6/79
 1DH3 Total of Dwell= Pulse Time*(1600/4)*31.6/79
 1DH5 Total of Dwell= Pulse Time*(1600/6)*31.6/79

**GFSK Hopping Mode 1DH1
2441 MHz**

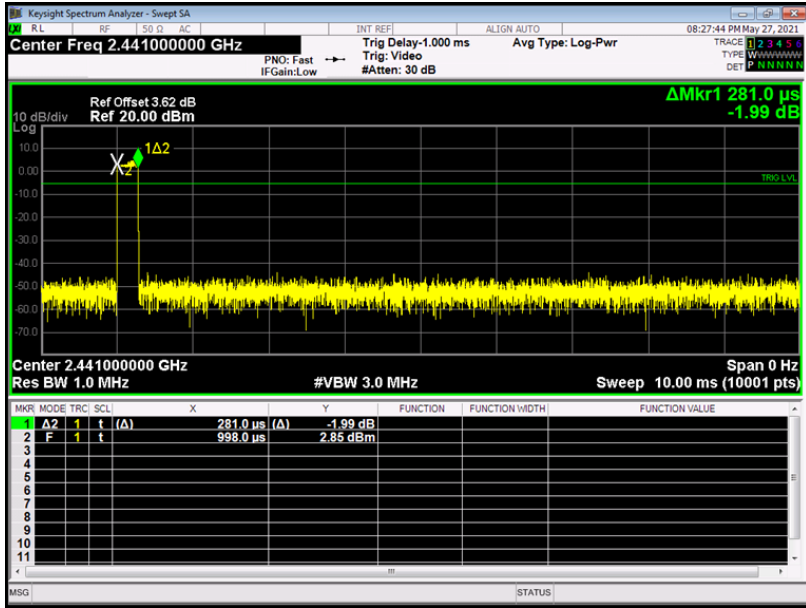

GFSK Hopping Mode 1DH3

2441 MHz

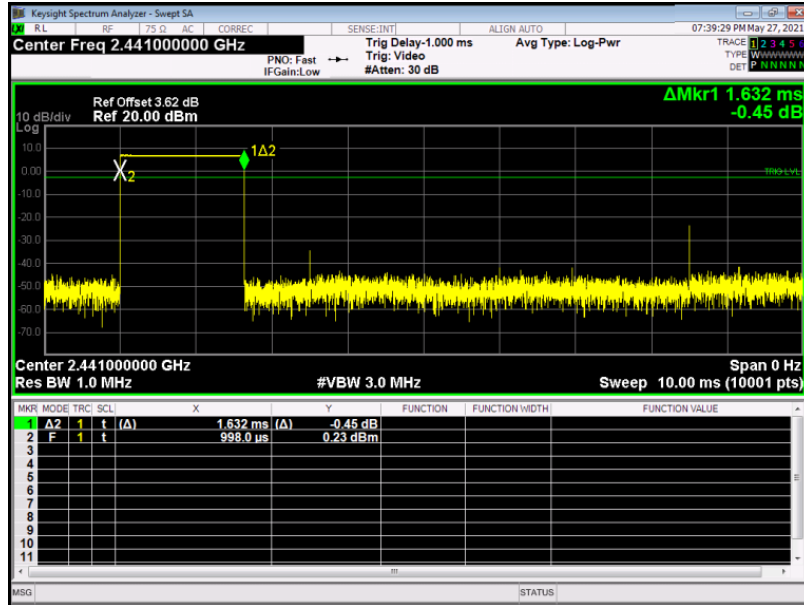

GFSK Hopping Mode 1DH5

2441 MHz

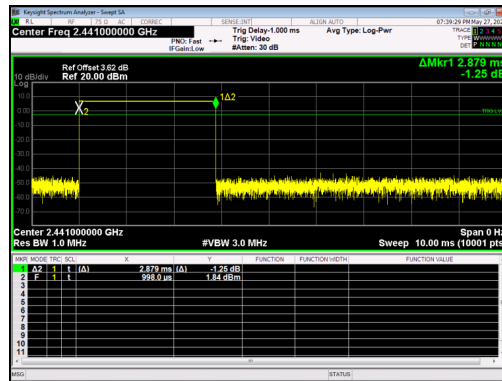

| Temperature: | | 25°C | | Relative Humidity: | | 55% | | | | | | | | | | | | | | | | | | | | | | | | | | | | |
|---|---------------|--------------------------------|---------------------|---------------------------|---------------|--------------|----------------|----------------|------|-----|-----|---|---|----------|----------------|----------------|---|------------|---|---|--------------|---------------|--------------|---------|--|---|---|---|---|--|---------------|--|-----------|--|
| Test Voltage: | | AC 120V/60 Hz | | | | | | | | | | | | | | | | | | | | | | | | | | | | | | | | |
| Test Mode: | | Hopping Mode ($\pi/4$ -DQPSK) | | | | | | | | | | | | | | | | | | | | | | | | | | | | | | | | |
| Test Mode | Channel (MHz) | Pulse Time (ms) | Total of Dwell (ms) | Period Time (s) | Limit (ms) | Result | | | | | | | | | | | | | | | | | | | | | | | | | | | | |
| 2DH1 | 2441 | 0.389 | 124.48 | 31.60 | 400 | PASS | | | | | | | | | | | | | | | | | | | | | | | | | | | | |
| 2DH3 | 2441 | 1.641 | 262.56 | 31.60 | 400 | PASS | | | | | | | | | | | | | | | | | | | | | | | | | | | | |
| 2DH5 | 2441 | 2.889 | 308.16 | 31.60 | 400 | PASS | | | | | | | | | | | | | | | | | | | | | | | | | | | | |
| <p>2DH1 Total of Dwell= Pulse Time*(1600/2)*31.6/79</p> <p>2DH3 Total of Dwell= Pulse Time*(1600/4)*31.6/79</p> <p>2DH5 Total of Dwell= Pulse Time*(1600/6)*31.6/79</p> | | | | | | | | | | | | | | | | | | | | | | | | | | | | | | | | | | |
| <p>$\pi/4$-DQPSK Hopping Mode 2DH1</p> <p>2441 MHz</p> | | | | | | | | | | | | | | | | | | | | | | | | | | | | | | | | | | |
| <p>Keysight Spectrum Analyzer - Swept SA</p> <p>Center Freq 2.441000000 GHz</p> <p>Ref Offset 3.62 dB</p> <p>Ref 20.00 dBm</p> <p>ΔMkr1 389.0 μs</p> <p>1.34 dB</p> <p>Center 2.441000000 GHz</p> <p>Res BW 1.0 MHz</p> <p>#VBW 3.0 MHz</p> <p>Sweep 10.00 ms (10001 pts)</p> <table border="1"> <thead> <tr> <th>MKR</th> <th>MODE</th> <th>TRC</th> <th>SCL</th> <th>X</th> <th>Y</th> <th>FUNCTION</th> <th>FUNCTION WIDTH</th> <th>FUNCTION VALUE</th> </tr> </thead> <tbody> <tr> <td>1</td> <td>Δ2</td> <td>1</td> <td>t</td> <td>(Δ)</td> <td>389.0 μs</td> <td>(Δ)</td> <td>1.34 dB</td> <td></td> </tr> <tr> <td>2</td> <td>F</td> <td>1</td> <td>t</td> <td></td> <td>781.0 μs</td> <td></td> <td>-9.68 dBm</td> <td></td> </tr> </tbody> </table> | | | | | | | | MKR | MODE | TRC | SCL | X | Y | FUNCTION | FUNCTION WIDTH | FUNCTION VALUE | 1 | Δ 2 | 1 | t | (Δ) | 389.0 μ s | (Δ) | 1.34 dB | | 2 | F | 1 | t | | 781.0 μ s | | -9.68 dBm | |
| MKR | MODE | TRC | SCL | X | Y | FUNCTION | FUNCTION WIDTH | FUNCTION VALUE | | | | | | | | | | | | | | | | | | | | | | | | | | |
| 1 | Δ 2 | 1 | t | (Δ) | 389.0 μ s | (Δ) | 1.34 dB | | | | | | | | | | | | | | | | | | | | | | | | | | | |
| 2 | F | 1 | t | | 781.0 μ s | | -9.68 dBm | | | | | | | | | | | | | | | | | | | | | | | | | | | |

$\pi/4$ -DQPSK Hopping Mode 2DH3

2441 MHz

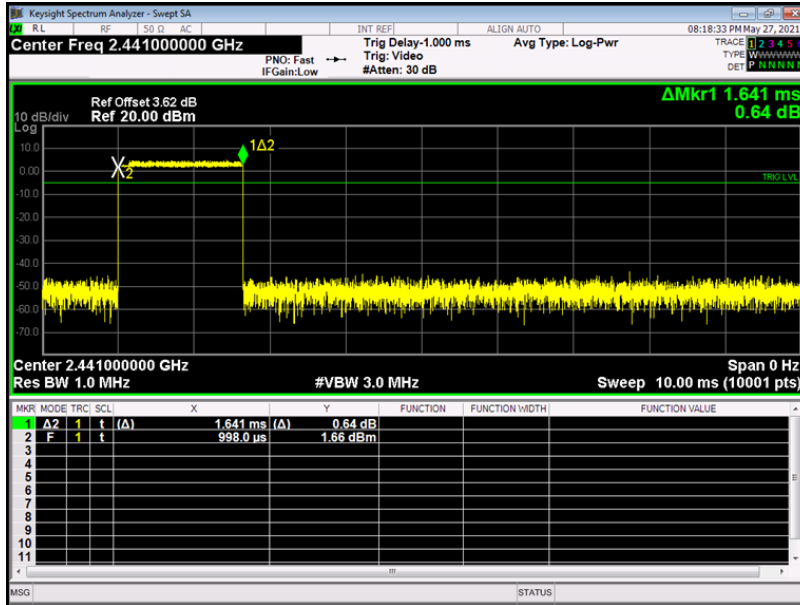

$\pi/4$ -DQPSK Hopping Mode 2DH5

2441 MHz

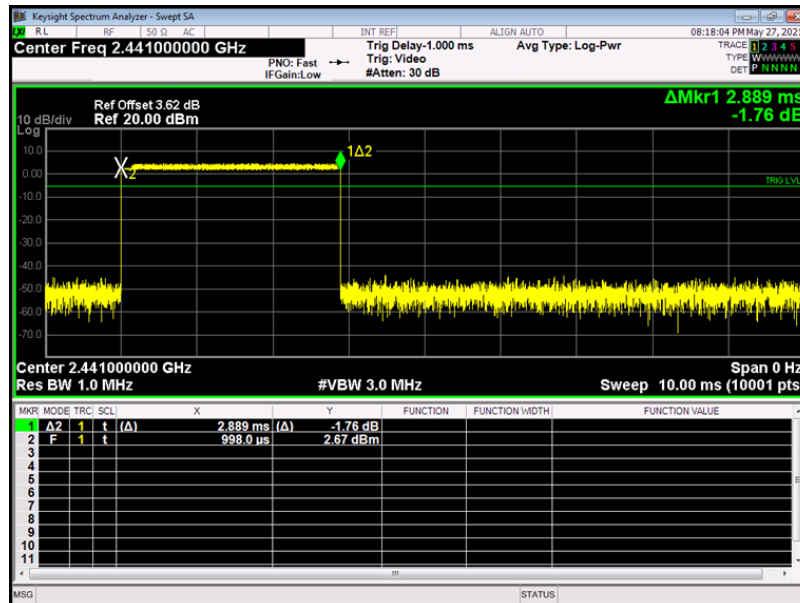

| Temperature: | | 25°C | | Relative Humidity: | | 55% |
|----------------------|---------------|----------------------|---------------------|---------------------------|------------|--------|
| Test Voltage: | | AC 120V/60 Hz | | | | |
| Test Mode: | | Hopping Mode (8DPSK) | | | | |
| Test Mode | Channel (MHz) | Pulse Time (ms) | Total of Dwell (ms) | Period Time (s) | Limit (ms) | Result |
| 3DH1 | 2441 | 0.389 | 124.48 | 31.60 | 400 | PASS |
| 3DH3 | 2441 | 1.641 | 262.56 | 31.60 | 400 | PASS |
| 3DH5 | 2441 | 2.891 | 308.373 | 31.60 | 400 | PASS |

1DH1 Total of Dwell= Pulse Time*(1600/2)*31.6/79
 1DH3 Total of Dwell= Pulse Time*(1600/4)*31.6/79
 1DH5 Total of Dwell= Pulse Time*(1600/6)*31.6/79

8DPSK Hopping Mode 3DH1

2441 MHz

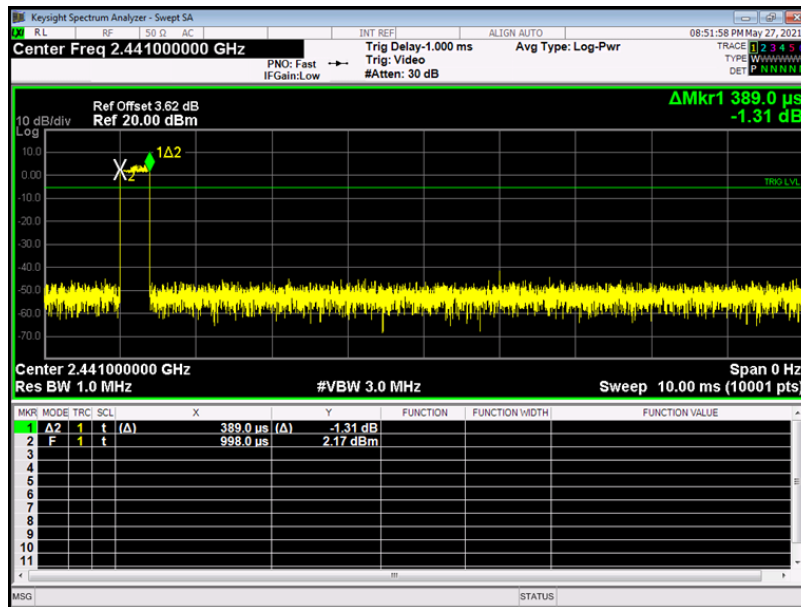

8DPSK Hopping Mode 3DH3

2441 MHz

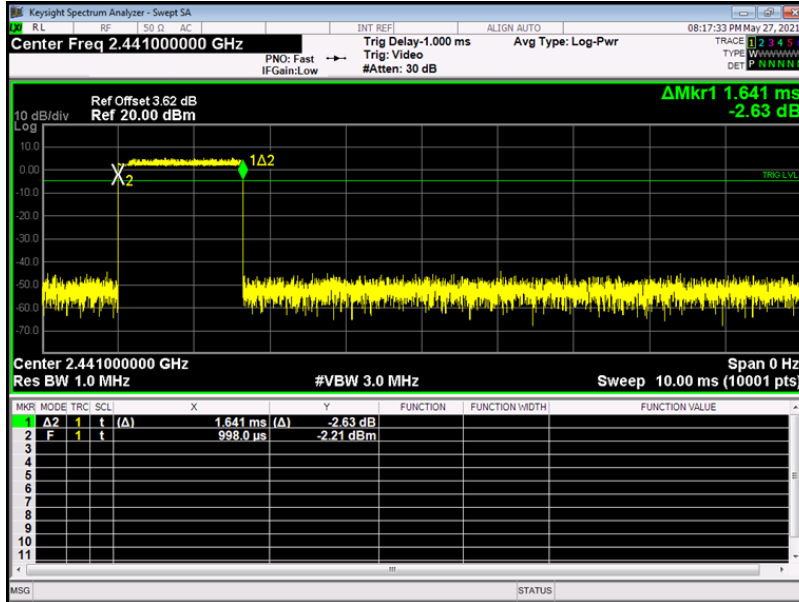

8DPSK Hopping Mode 3DH5

2441 MHz

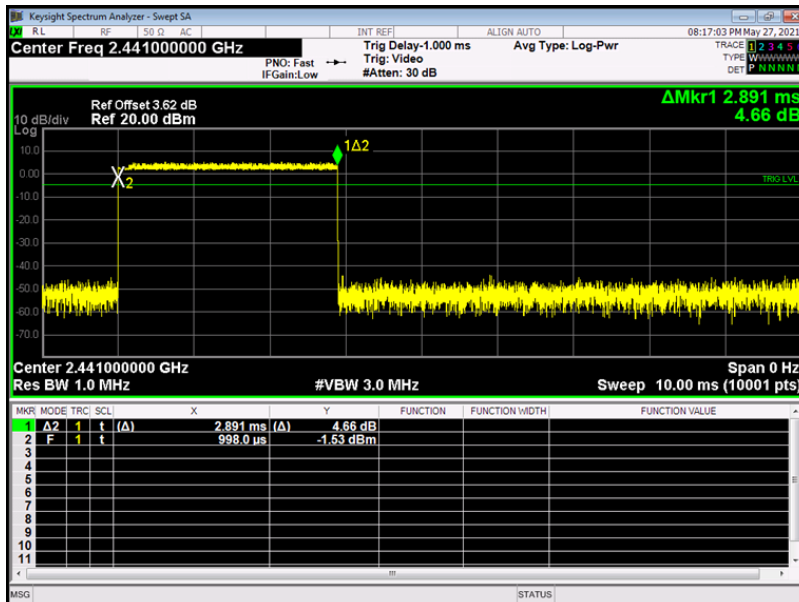

Attachment G-- Channel Separation and Bandwidth Test Data

| Temperature: | 25°C | Relative Humidity: | 55% | | | | | | | | | | | | |
|---|-------------------|----------------------|---------------------------|--------------------|-------------------|-------------|----------|---------------------|-----------|----------------|---------|----------------|-----------|------|-----------|
| Test Voltage: | AC 120V/60 Hz | | | | | | | | | | | | | | |
| Test Mode: | TX Mode (GFSK) | | | | | | | | | | | | | | |
| Channel frequency (MHz) | 99% OBW (kHz) | 20dB Bandwidth (kHz) | 20dB Bandwidth *2/3 (kHz) | | | | | | | | | | | | |
| 2402 | 1215.9 | 1353 | 0.886 | | | | | | | | | | | | |
| 2441 | 1156.4 | 1334 | 0.889 | | | | | | | | | | | | |
| 2480 | 1140.8 | 1278 | 0.852 | | | | | | | | | | | | |
| GFSK TX Mode | | | | | | | | | | | | | | | |
| 2402 MHz | | | | | | | | | | | | | | | |
| <p>Keysight Spectrum Analyzer - Occupied BW Center Freq 2.441000000 GHz Center Freq: 2.441000000 GHz Trig: Free Run #Atten: 30 dB AvgHold: 100/100 Radio Std: None Radio Device: BTS #Gain: Low Ref Offset 3.62 dB Ref 23.62 dBm 10 dB/div Log Center 2.441 GHz #Res BW 30 kHz #VBW 100 kHz Span 3 MHz Sweep 3.333 ms</p> <table border="1"> <tr> <td>Occupied Bandwidth</td> <td>1.2159 MHz</td> <td>Total Power</td> <td>7.75 dBm</td> </tr> <tr> <td>Transmit Freq Error</td> <td>2.890 kHz</td> <td>% of OBW Power</td> <td>99.00 %</td> </tr> <tr> <td>x dB Bandwidth</td> <td>1.353 MHz</td> <td>x dB</td> <td>-20.00 dB</td> </tr> </table> | | | | Occupied Bandwidth | 1.2159 MHz | Total Power | 7.75 dBm | Transmit Freq Error | 2.890 kHz | % of OBW Power | 99.00 % | x dB Bandwidth | 1.353 MHz | x dB | -20.00 dB |
| Occupied Bandwidth | 1.2159 MHz | Total Power | 7.75 dBm | | | | | | | | | | | | |
| Transmit Freq Error | 2.890 kHz | % of OBW Power | 99.00 % | | | | | | | | | | | | |
| x dB Bandwidth | 1.353 MHz | x dB | -20.00 dB | | | | | | | | | | | | |

GFSK TX Mode

2441 MHz

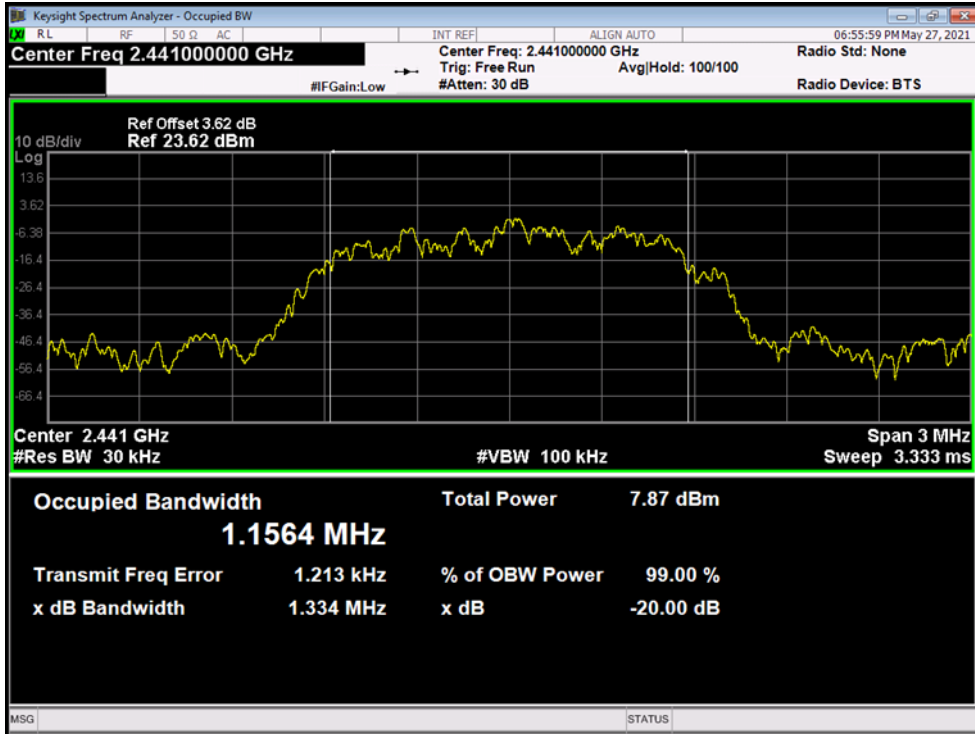

GFSK TX Mode

2480 MHz

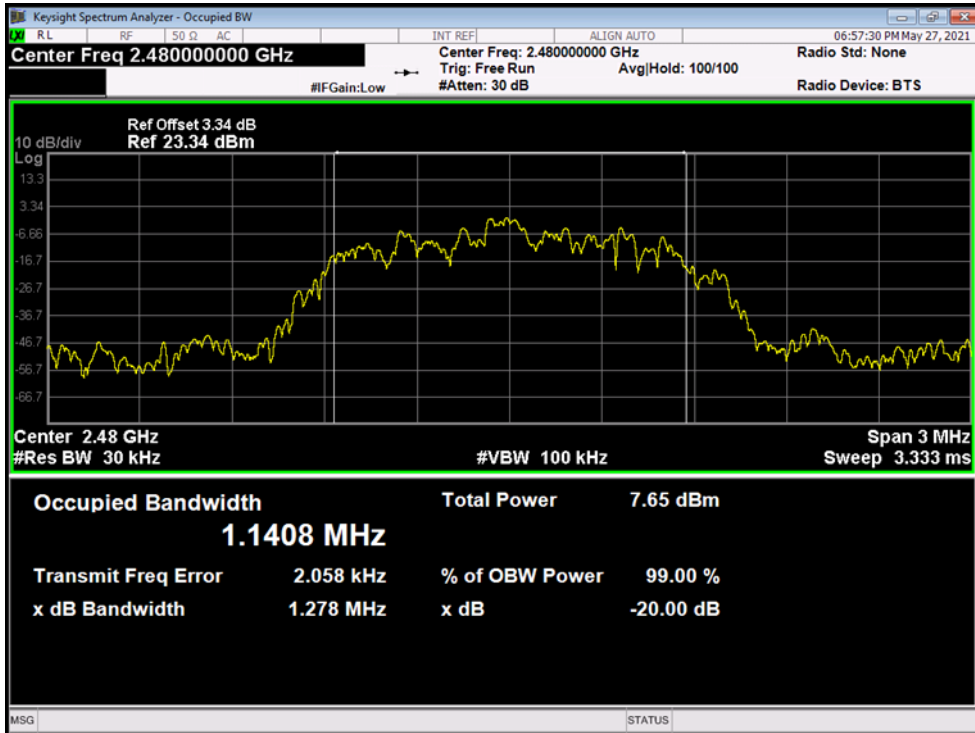

| | | | |
|--------------------------------|---------------------------|-----------------------------|----------------------------------|
| Temperature: | 25°C | Relative Humidity: | 55% |
| Test Voltage: | AC 120V/60 Hz | | |
| Test Mode: | TX Mode ($\pi/4$ -DQPSK) | | |
| Channel frequency (MHz) | 99% OBW (kHz) | 20dB Bandwidth (kHz) | 20dB Bandwidth *2/3 (kHz) |
| 2402 | 1159.5 | 1296.0 | 864 |
| 2441 | 1215.9 | 1353.0 | 902 |
| 2480 | 1187.1 | 1290.0 | 860 |

$\pi/4$ -DQPSK TX Mode

2402 MHz

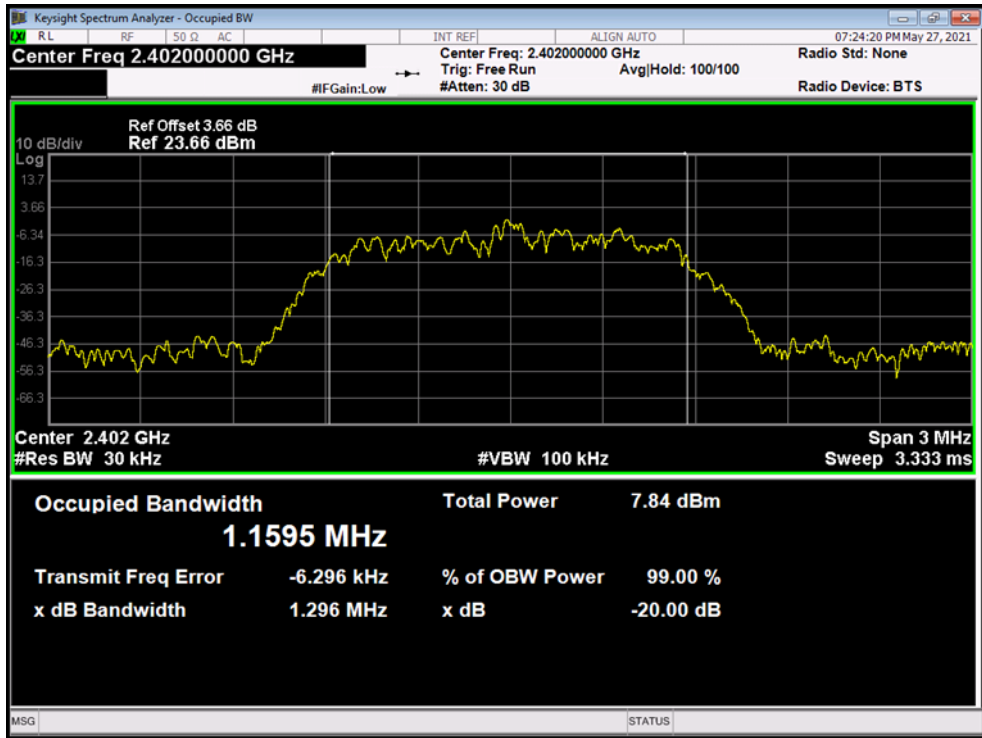

$\pi/4$ -DQPSK TX Mode

2441 MHz

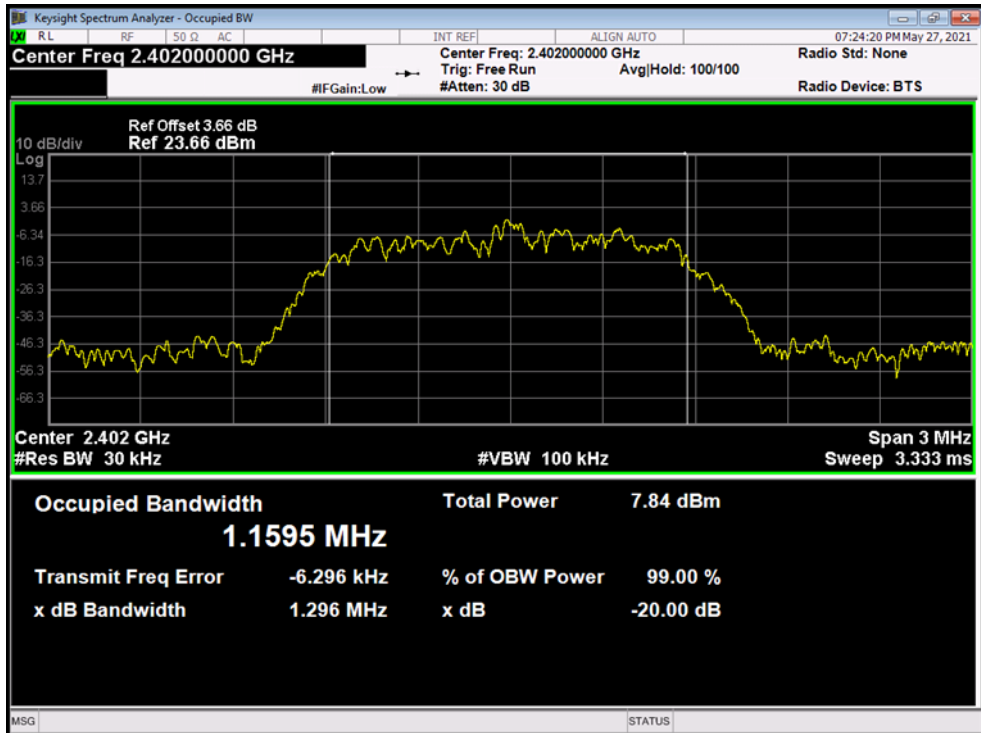

$\pi/4$ -DQPSK TX Mode

2480 MHz

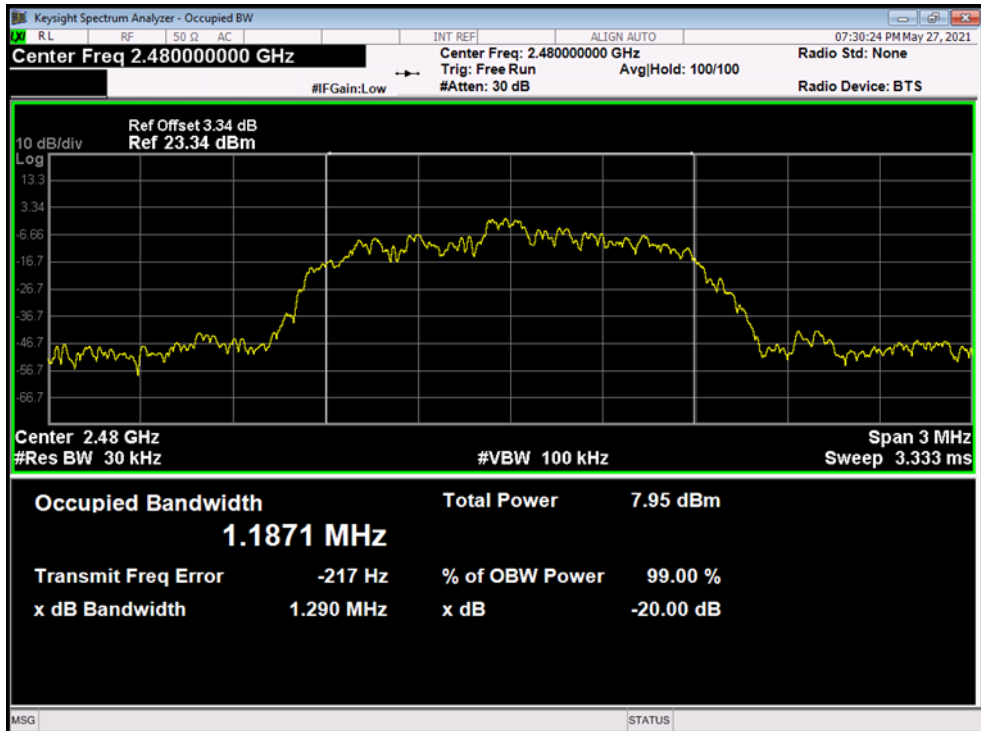

| | | | |
|--------------------------------|----------------------|-----------------------------|----------------------------------|
| Temperature: | 25°C | Relative Humidity: | 55% |
| Test Voltage: | AC 120V/60 Hz | | |
| Test Mode: | TX Mode (8DPSK) | | |
| Channel frequency (MHz) | 99% OBW (kHz) | 20dB Bandwidth (kHz) | 20dB Bandwidth *2/3 (kHz) |
| 2402 | 1155.1 | 1300.0 | 866.66 |
| 2441 | 1182.4 | 1272.0 | 848 |
| 2480 | 1181.2 | 1316.0 | 877.33 |

8DPSK TX Mode

2402 MHz

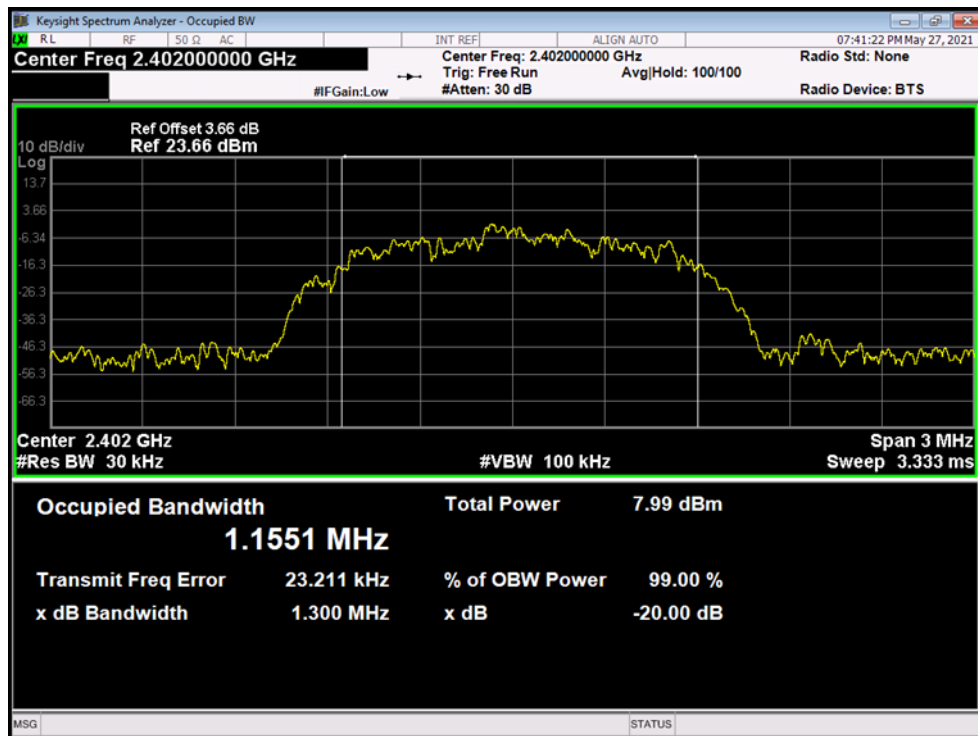

8DPSK TX Mode

2441 MHz

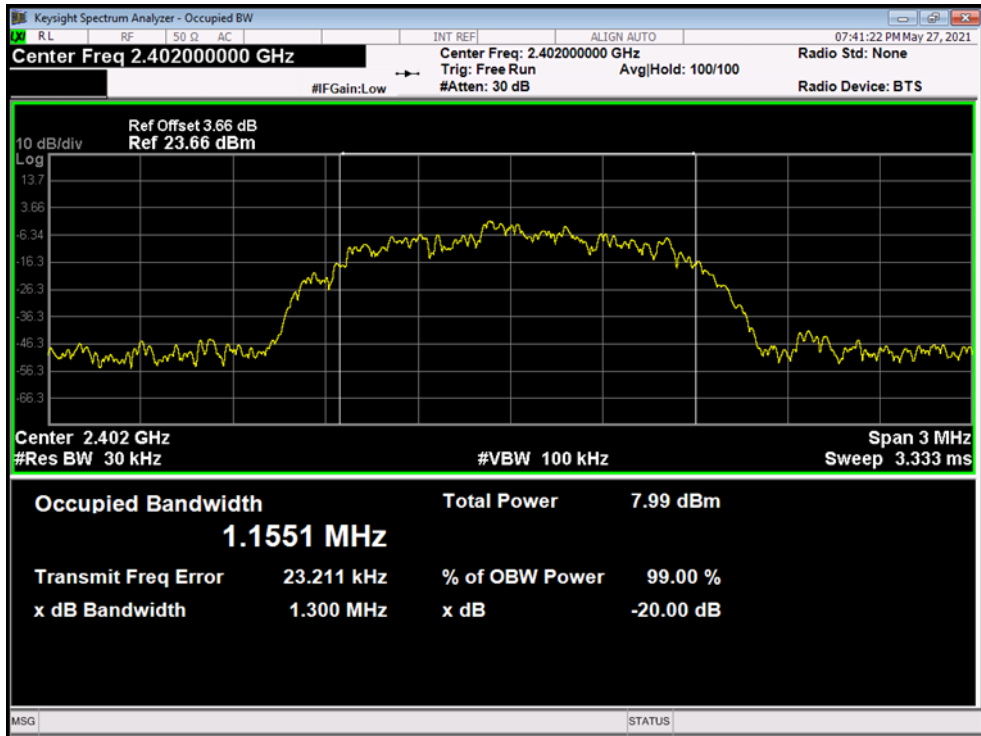

8DPSK TX Mode

2480 MHz

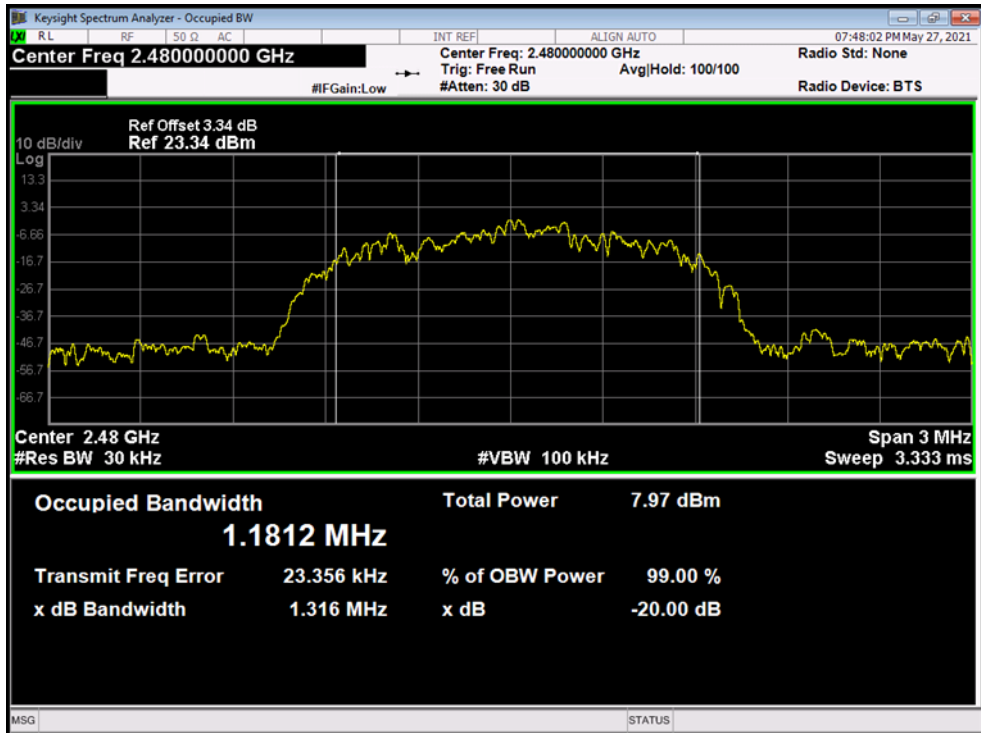

| | | | |
|--------------------------------|------------------------------------|-------------------------------|-----|
| Temperature: | 25°C | Relative Humidity: | 55% |
| Test Voltage: | AC 120V/60 Hz | | |
| Test Mode: | Hopping Mode (GFSK) | | |
| Channel frequency (MHz) | Separation Read Value (kHz) | Separation Limit (kHz) | |
| 2441 | 0.984 | 0.889 | |

GFSK Hopping Mode

2441 MHz

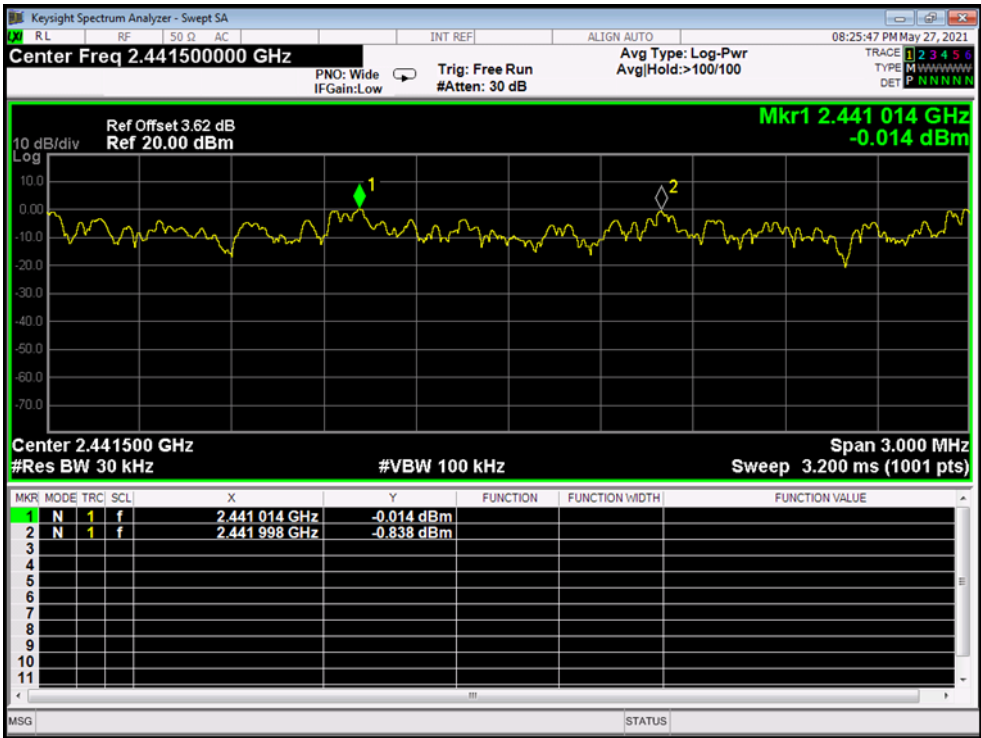

| | | | |
|--------------------------------|------------------------------------|-------------------------------|-----|
| Temperature: | 25°C | Relative Humidity: | 55% |
| Test Voltage: | AC 120V/60 Hz | | |
| Test Mode: | Hopping Mode ($\pi/4$ -DQPSK) | | |
| Channel frequency (MHz) | Separation Read Value (kHz) | Separation Limit (kHz) | |
| 2441 | 0.999 | 902 | |

$\pi/4$ -DQPSK Hopping Mode

2441 MHz

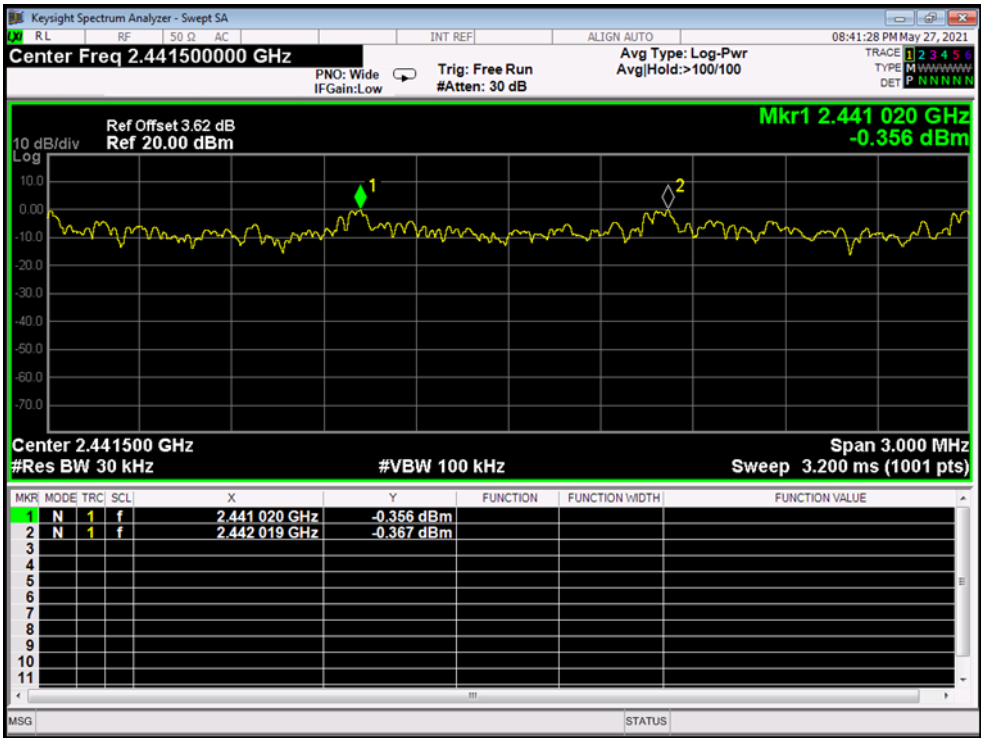

| | | | |
|-------------------------|-----------------------------|------------------------|-----|
| Temperature: | 25°C | Relative Humidity: | 55% |
| Test Voltage: | AC 120V/60 Hz | | |
| Test Mode: | Hopping Mode (8DPSK) | | |
| Channel frequency (MHz) | Separation Read Value (kHz) | Separation Limit (kHz) | |
| 2441 | 1.026 | 848 | |

8DPSK Hopping Mode

2441 MHz

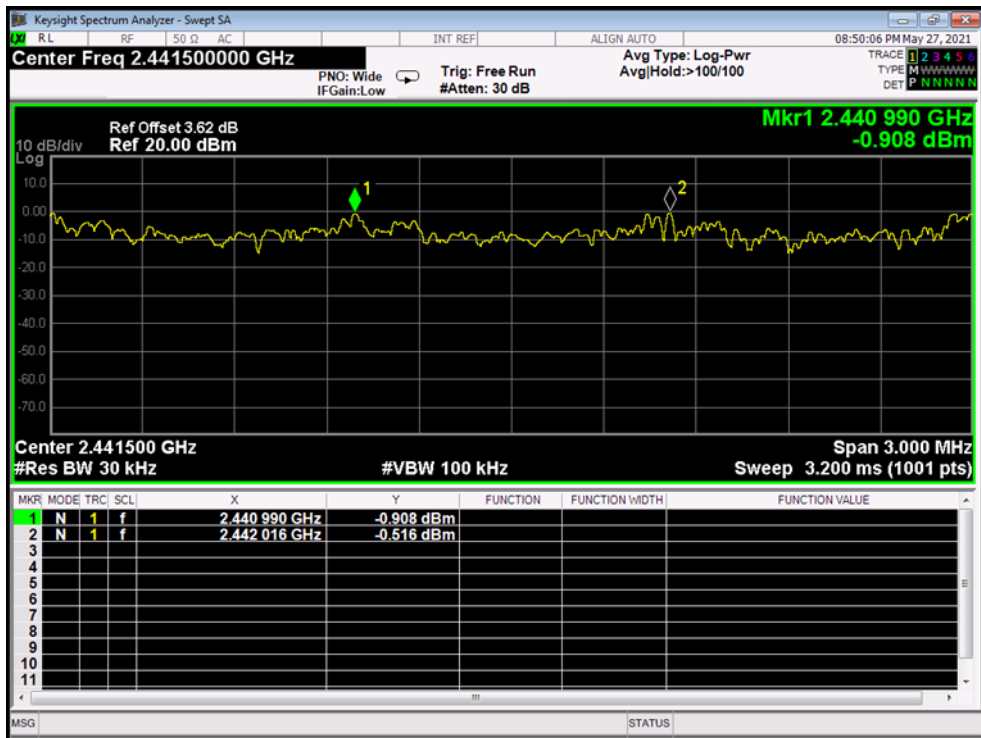

Attachment H-- Peak Output Power Test Data

| | | | |
|--------------------------------|--------------------------|---------------------------|-----|
| Temperature: | 25°C | Relative Humidity: | 55% |
| Test Voltage: | AC 120V/60 Hz | | |
| Test Mode: | TX Mode (GFSK) | | |
| Channel frequency (MHz) | Test Result (dBm) | Limit (dBm) | |
| 2402 | 4.637 | 21 | |
| 2441 | 5.089 | | |
| 2480 | 4.514 | | |

GFSK TX Mode

2402 MHz

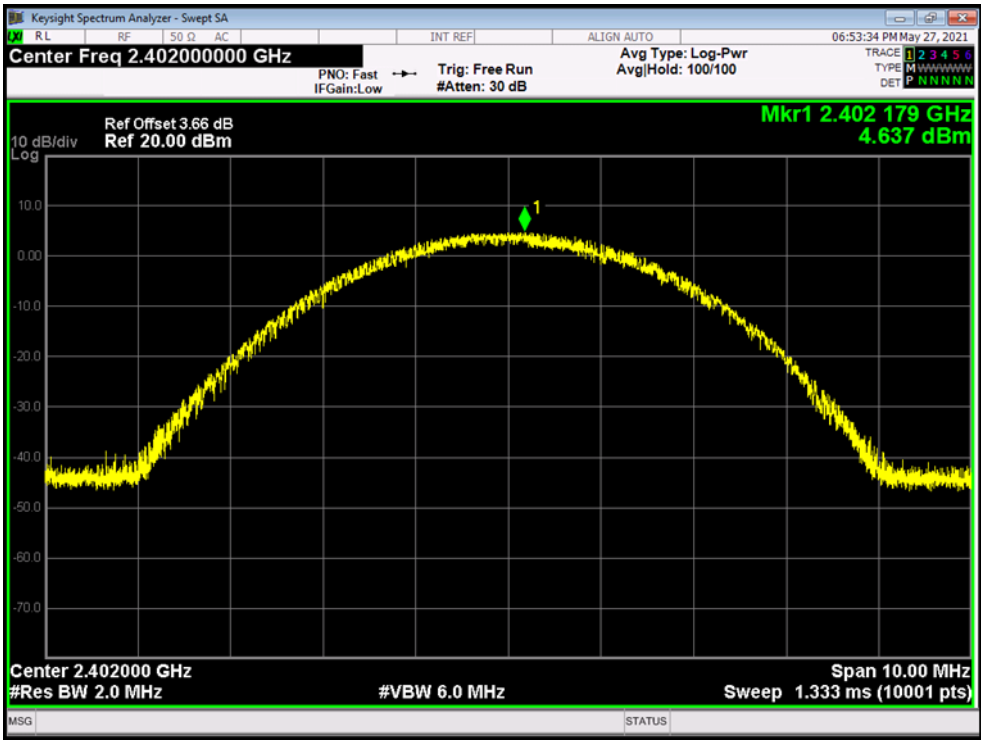

GFSK TX Mode

2441 MHz

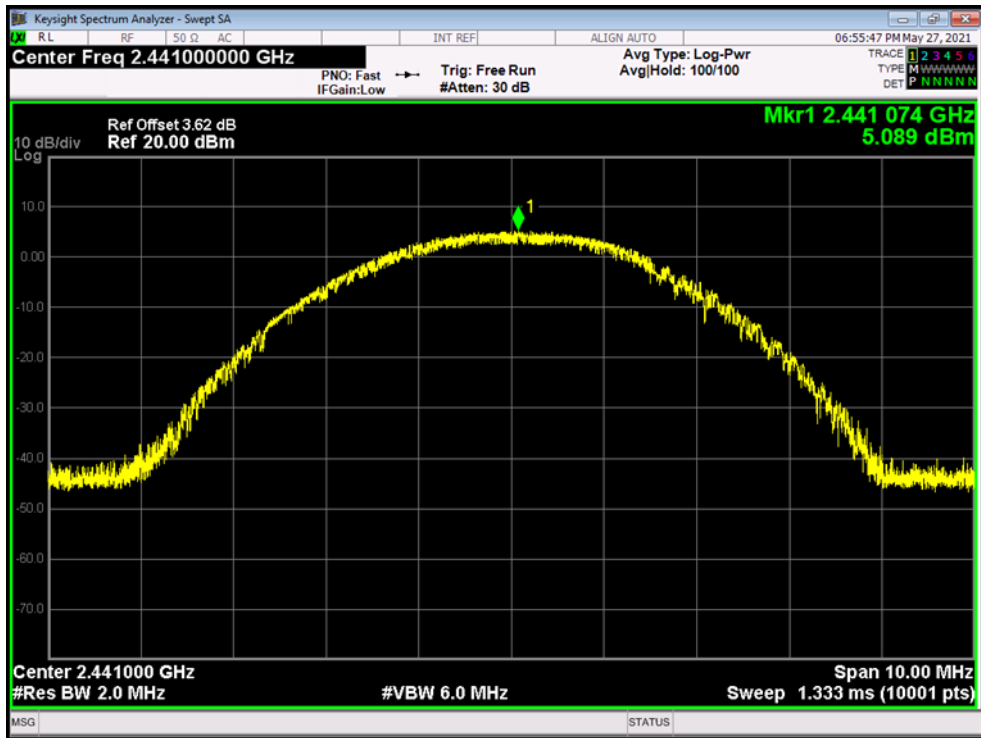

GFSK TX Mode

2480 MHz

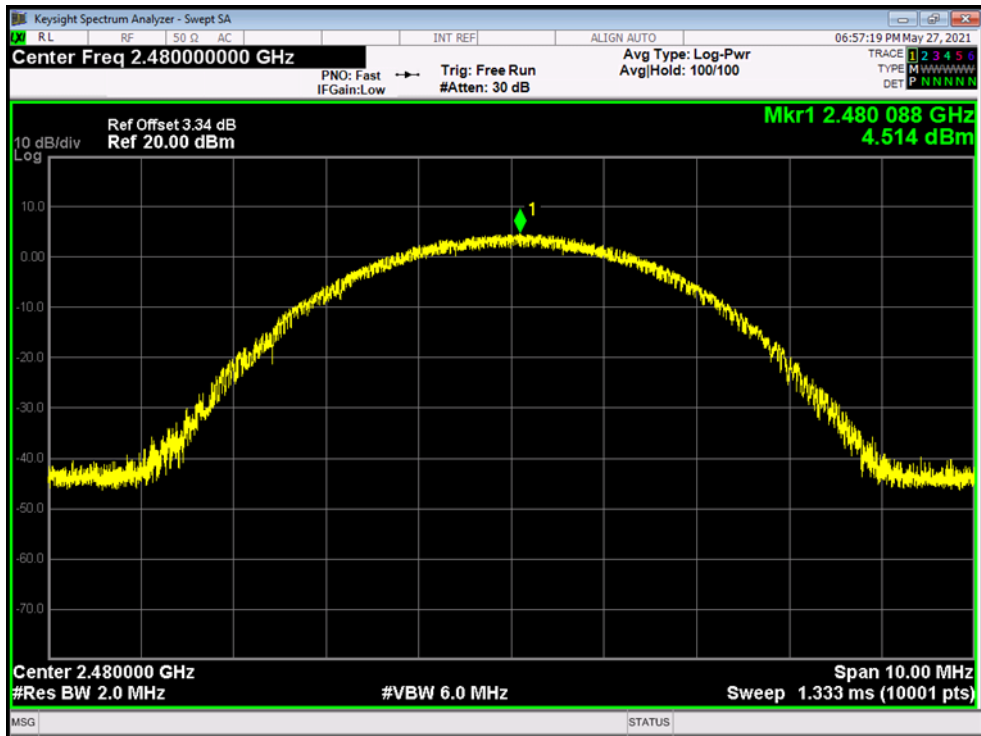

| | | | |
|--------------------------------|---------------------------|---------------------------|-----|
| Temperature: | 25°C | Relative Humidity: | 55% |
| Test Voltage: | AC 120V/60 Hz | | |
| Test Mode: | TX Mode ($\pi/4$ -DQPSK) | | |
| Channel frequency (MHz) | Test Result (dBm) | Limit (dBm) | |
| 2402 | 4.705 | 21 | |
| 2441 | 5.16 | | |
| 2480 | 4.148 | | |

$\pi/4$ -DQPSK TX Mode

2402 MHz

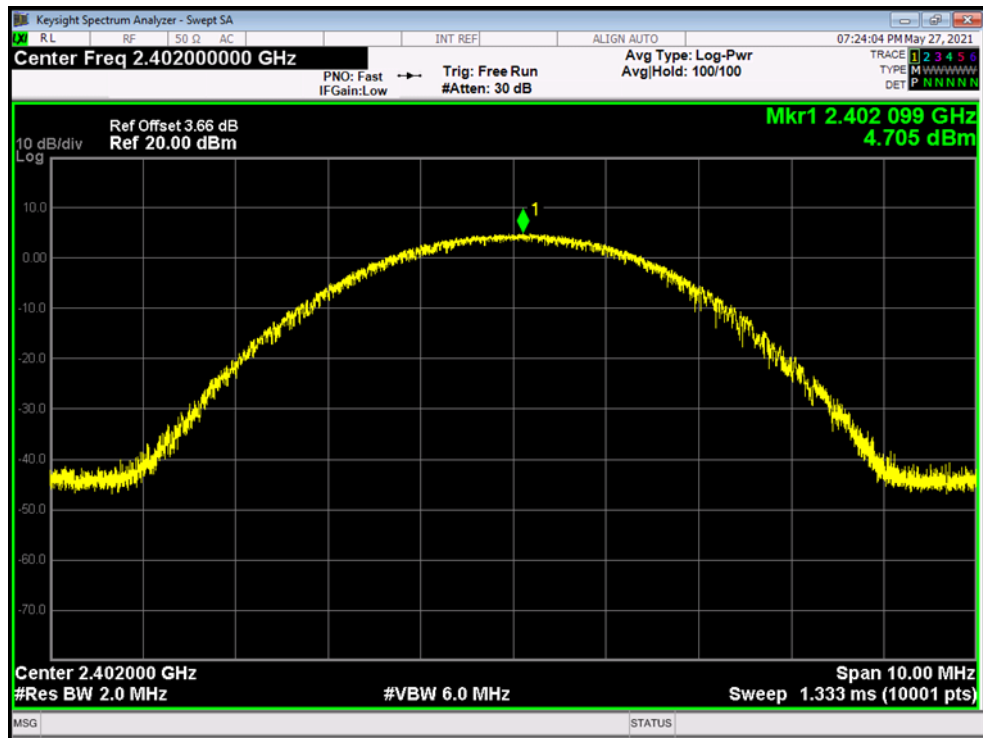

$\pi/4$ -DQPSK TX Mode

2441 MHz

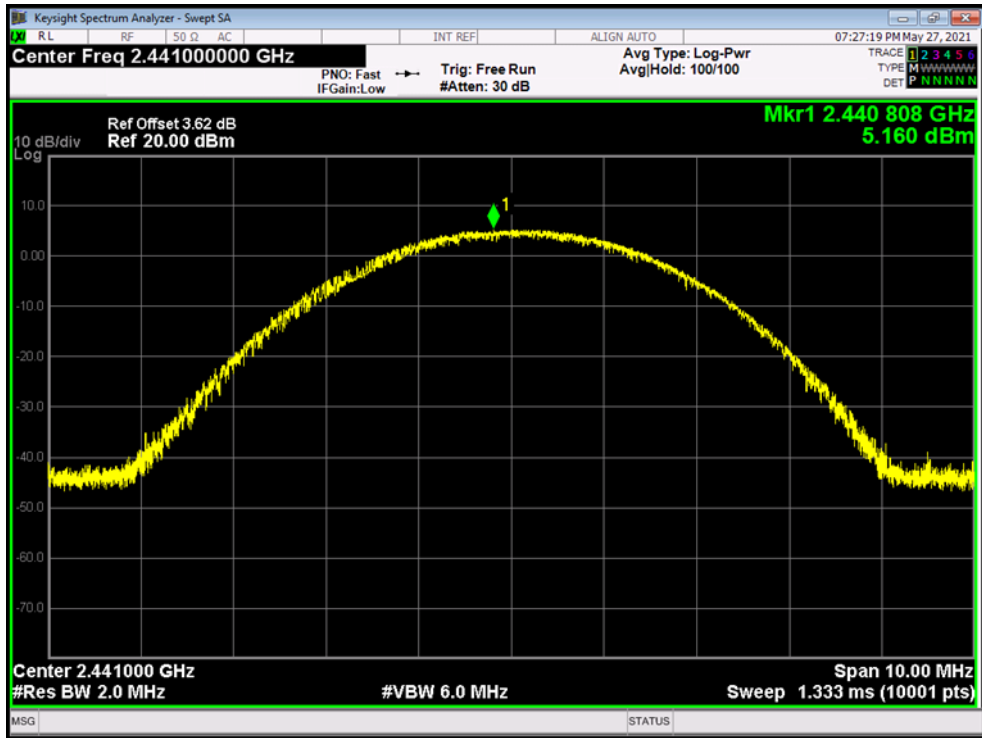

$\pi/4$ -DQPSK TX Mode

2480 MHz

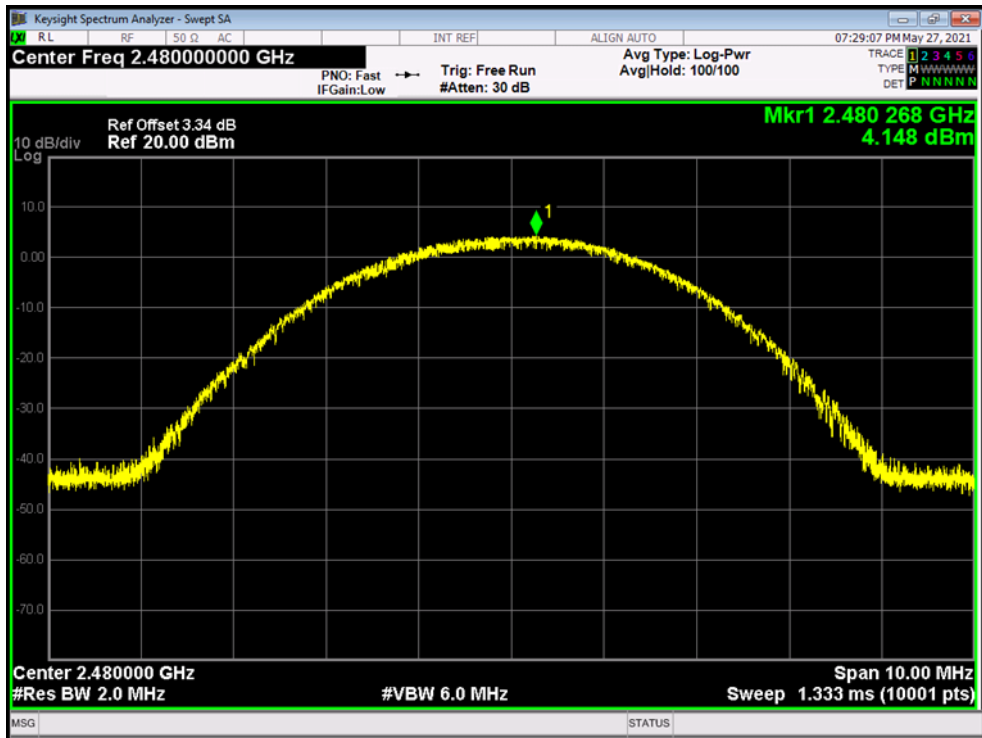

| Temperature: | 25°C | Relative Humidity: | 55% |
|-------------------------|-------------------|--------------------|-----|
| Test Voltage: | AC 120V/60 Hz | | |
| Test Mode: | TX Mode (8DPSK) | | |
| Channel frequency (MHz) | Test Result (dBm) | Limit (dBm) | |
| 2402 | 4.296 | 21 | |
| 2441 | 5.831 | | |
| 2480 | 5.166 | | |

8DPSK TX Mode

2402 MHz

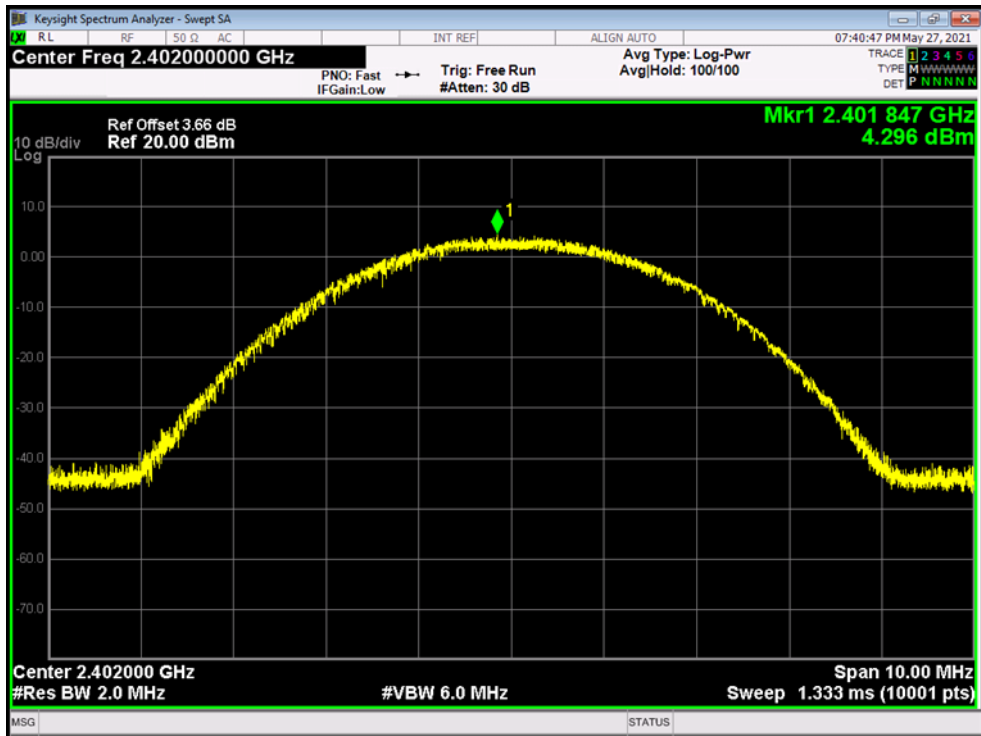

8DPSK TX Mode

2441 MHz

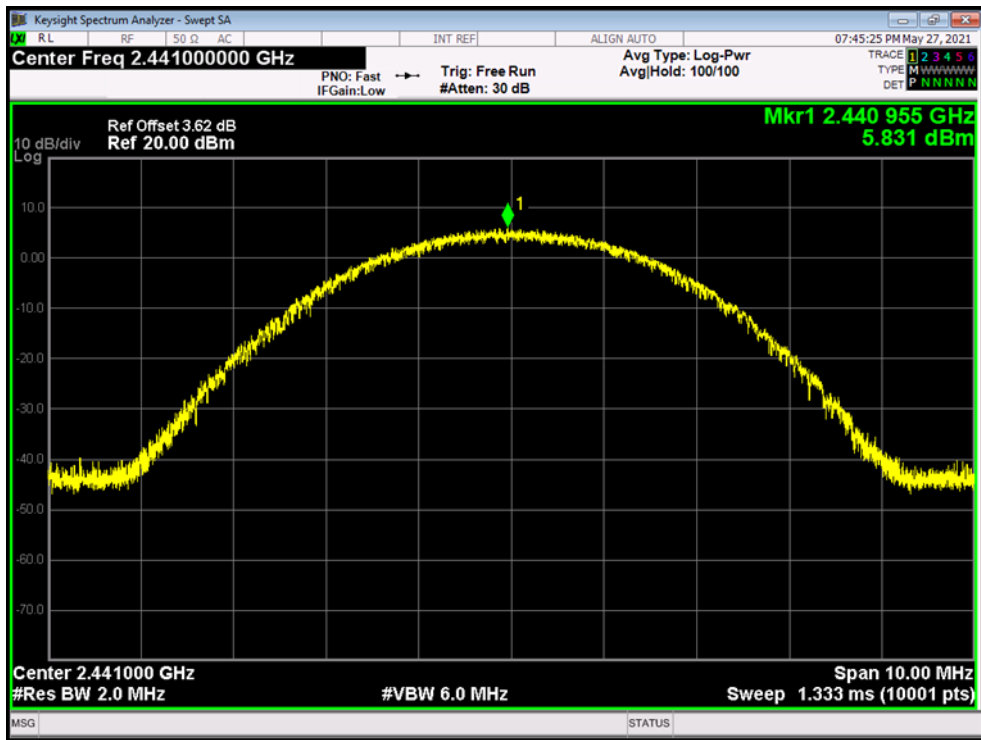

8DPSK TX Mode

2480 MHz

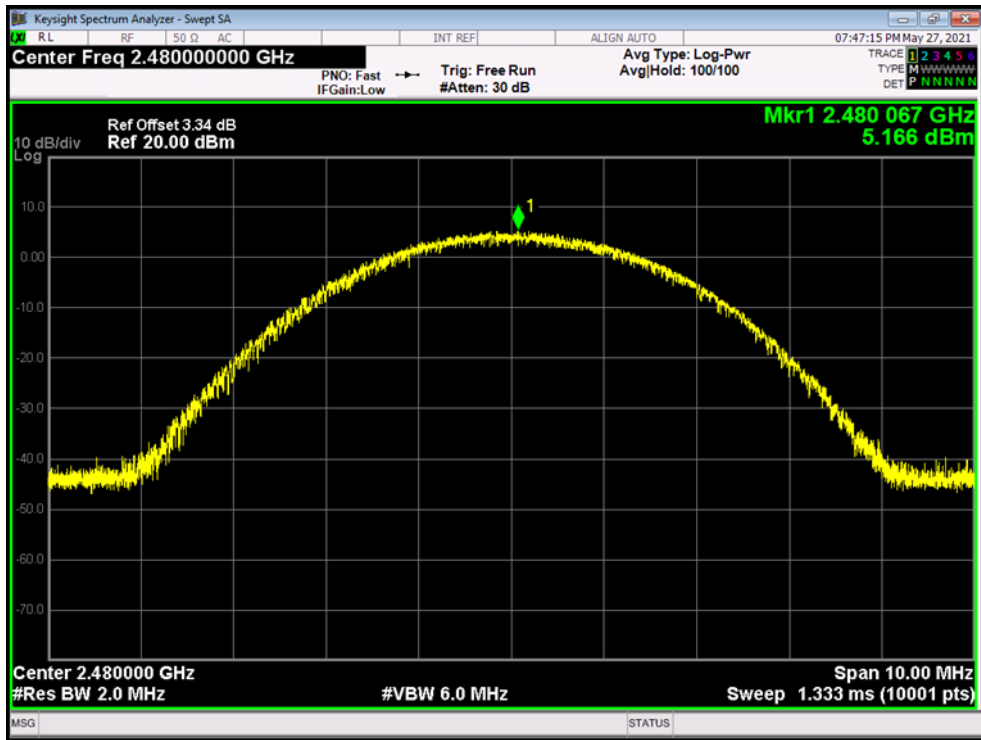

-----END OF REPORT-----