

EMC TEST REPORT

Certificate No. : TB210528151
Applicant : Navori SA
Equipment Under Test (EUT)
EUT Name : StiX
Model No. : 3700
Series Model No. : N/A
Brand Name : Navori
Receipt Date : 2021-05-14
Test Date : 2021-05-14 to 2021-06-22
Issue Date : 2021-06-22
Standards : ETSI EN 301 489-1 V2.2.3:2019
ETSI EN 301 489-17 V3.2.4:2020
Conclusions : **PASS**

In the configuration tested, the EUT complied with the standards specified above. The EUT technically complies with the Council Directive 2014/53/EU relating to radio equipment.

Test/Witness Engineer : *Camille Li*
Engineer Supervisor : *Ivan Su*
Engineer Manager : *Ray Lai*



This report details the results of the testing carried out on one sample. The results contained in this test report do not relate to other samples of the same product. The manufacturer should ensure that all products in series production are in conformity with the product sample detailed in the report.

TABLE OF CONTENTS

1.	GENERAL INFORMATION	5
1.1	Client Information	5
1.2	General Description of EUT (Equipment Under Test)	5
1.3	Block Diagram Showing the Configuration of System Tested	6
1.4	Description of Support Units	6
1.5	Description of Operating Mode	7
1.6	Performance Criteria	8
1.7	Measurement Uncertainty	11
1.8	Test Facility	11
2	TEST RESULTS SUMMARY	12
3	TEST SOFTWARE.....	13
4	TEST EQUIPMENT USED	14
5	CONDUCTED DISTURBANCE TEST (AC PORT).....	16
5.1	Test Standard and Limit	16
5.2	Test Setup	16
5.3	Test Procedure	17
5.4	Deviation From Test Standard	17
5.5	Test Data	17
6	CONDUCTED EMISSION (WIRED NETWORK PORT)	18
6.1	Test Standard and Limit	18
6.2	Test Setup	18
6.3	Deviation From Test Standard	19
6.4	Test Data	19
7	RADIATED DISTURBANCE TEST	20
7.1	Test Standard and Limit.....	20
7.2	Test Setup.....	21
7.3	Test Procedure.....	21
7.4	Deviation From Test Standard.....	21
7.5	Test Data.....	21
8	HARMONIC CURRENT EMISSION TEST.....	22
8.1	Test Standard and Limit.....	22
8.2	Test Setup.....	22
8.3	Test Procedure.....	23
8.4	Deviation From Test Standard.....	23
8.5	Test Data.....	23
9	VOLTAGE FLUCTUATION AND FLICKER TEST.....	24
9.1	Test Standard and Limit.....	24
9.2	Test Setup.....	24
9.3	Test Procedure.....	25
9.4	Deviation From Test Standard.....	25
9.5	Test Data.....	25
10	ELECTROSTATIC DISCHARGE IMMUNITY TEST	26
10.1	Test Requirements	26
10.2	Test Setup.....	26
10.3	Test Procedure.....	27
10.4	Deviation From Test Standard.....	27
10.5	Test Data.....	27
11	RADIATED ELECTROMAGNETIC FIELD IMMUNITY TEST	28

11.1 Test Requirements	28
11.2 Test Setup.....	28
11.3 Test Procedure.....	29
11.4 Deviation From Test Standard.....	29
11.5 Test Data.....	29
12 ELECTRICAL FAST TRANSIENT/BURST TEST	30
12.1 Test Requirements	30
12.2 Test Setup.....	30
12.3 Test Procedure.....	31
12.4 Deviation From Test Standard.....	31
12.5 Test Data.....	31
13 SURGE IMMUNITY TEST.....	32
13.1 Test Requirements	32
13.2 Test Setup.....	33
13.3 Test Procedure.....	33
13.4 Deviation From Test Standard.....	33
13.5 Test Data.....	33
14 RF COMMON MODE.....	34
14.1 Test Requirements	34
14.2 Test Setup.....	34
14.3 Test Procedure.....	35
14.4 Deviation From Test Standard.....	35
14.5 Test Data.....	35
15 VOLTAGE DIPS AND INTERRUPTIONS IMMUNITY TEST	36
15.1 Test Requirements	36
15.2 Test Setup.....	36
15.3 Test Procedure.....	37
15.4 Deviation From Test Standard.....	37
15.5 Test Data.....	37
16 PHOTOGRAPHS - CONSTRUCTIONAL DETAILS	38
17 PHOTOGRAPHS –TEST SETUP.....	44
ATTACHMENT A--CONDUCTED EMISSION DATA (AC MAINS)	48
ATTACHMENT B--CONDUCTED EMISSION DATA (WIRED NETWORK PORT).....	50
ATTACHMENT B--RADIATED EMISSION TEST DATA	51
ATTACHMENT C--VOLTAGE FLUCTUATION AND FLICKER TEST DATA.....	55
ATTACHMENT D--ELECTROSTATIC DISCHARGE TEST DATA.....	56
ATTACHMENT E--RF FIELD STRENGTH SUSCEPTIBILITY TEST DATA.....	58
ATTACHMENT F--ELECTRICAL FAST TRANSIENT/BURST TEST DATA	59
ATTACHMENT G--SURGE IMMUNITY TEST DATA	60
ATTACHMENT H--CONDUCTED IMMUNITY TEST DATA	61
ATTACHMENT I--VOLTAGE DIPS AND INTERRUPTIONS TEST DATA	62

1. General Information

1.1 Client Information

Applicant	:	Navori SA
Address	:	Rue du Lion d'Or 4, CH-1003 Lausanne, Switzerland
Manufacturer	:	Shenzhen MicoRose Technology Co., Ltd.
Address	:	8B2A, Daqing Building, southeast of the intersection of Shennan Road and Guangshen Expressway, Futian District, Shenzhen, China

1.2 General Description of EUT (Equipment Under Test)

EUT Name	:	StiX
Model(s)	:	3700
Product Description	:	Operation Frequency: Bluetooth 5.0: 2402MHz~2480MHz
Software Version	:	android 9.0
Hardware Version	:	V1
Power Supply	:	For Adapter: Input: 100-240V~ Output: 5V $\overline{\text{---}}$, 2.5A

Note:

- (1) For a more detailed features description, please refer to the manufacturer's specifications or the User's Manual.
- (2) More information about the RF function, please refer the RF test reports.

1.3 Block Diagram Showing the Configuration of System Tested

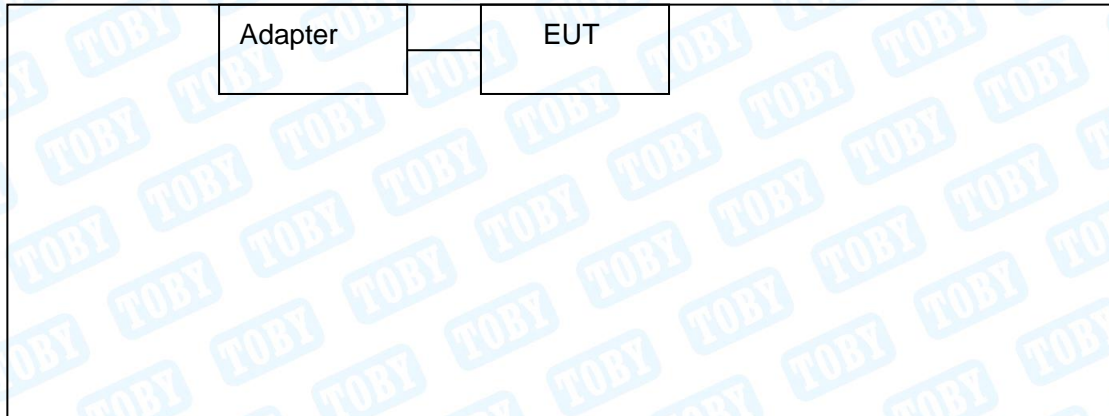

1.4 Description of Support Units

Equipment Information				
Name	Model	S/N	Manufacturer	Used “√”
Adapter	FJ-SW7260502500DE	-----	-----	√
Cable Information				
Number	Shielded Type	Ferrite Core	Length	Note
-----	-----	-----	-----	-----

1.5 Description of Operating Mode

To investigate the maximum EMI emission characteristics generated from EUT, the test system was pre-scanning tested based on the consideration of following EUT operation mode or test configuration mode which possible have effect on EMI emission level. Each of these EUT operation mode(s) or test configuration mode(s) mentioned above was evaluated respectively.

Pretest Mode	Description
Mode 1	RJ 45 Port Mode
Mode 2	USB Port Mode
Mode 3	WIFI Link Mode
Mode 4	BT Link Mode
Mode 5	TF Card Port Mode
Mode 6	Micro Port Mode
Mode 7	HDMI Port Mode

The EUT system operated these modes were found to be the worst case during the pre-scanning test as Following:

For EMI Test	
Final Test Mode	Description
Mode 1	RJ 45 Port Mode
Mode 7	HDMI Port Mode
For EMS Test	
Final Test Mode	Description
Mode 7	HDMI Port Mode

1.6 Performance Criteria

ETSI EN 301 489-1

(1) Introduction

The performance criteria are used to take a decision on whether a radio equipment passes or fails immunity tests. For the purpose of the present document two categories of performance criteria apply:

- Performance criteria for continuous phenomena.
- Performance criteria for transient phenomena.

NOTE: Normally, the performance criteria depends upon the type of radio equipment and/or its intended application. Thus, the present document only contains general performance criteria commonly used for the assessment of radio equipment.

(2) Performance criteria for continuous phenomena

During the test, the equipment shall:

- continue to operate as intended;
- not unintentionally transmit;
- not unintentionally change its operating state;
- not unintentionally change critical stored data.

(2) Performance criteria for transient phenomena

For all ports and transient phenomena with the exception described below, the following applies:

- The application of the transient phenomena shall not result in a change of the mode of operation (e.g. unintended transmission) or the loss of critical stored data.
- After application of the transient phenomena, the equipment shall operate as intended.

For surges applied to symmetrically operated wired network ports intended to be connected directly to outdoor lines the following criteria applies:

- For products with only one symmetrical port intended for connection to outdoor lines, loss of function is allowed, provided the function is self-recoverable, or can be otherwise restored. Information stored in non-volatile memory, or protected by a battery backup, shall not be lost.
- For products with more than one symmetrical port intended for connection to outdoor lines, loss of function on the port under test is allowed, provided the function is self-recoverable. Information stored in non-volatile memory, or protected by a battery backup, shall not be lost.

ETSI EN 301 489-17

(1) General performance criteria

The performance criteria are:

- performance criteria A for immunity tests with phenomena of a continuous nature;
- performance criteria B for immunity tests with phenomena of a transient nature;
- performance criteria C for immunity tests with power interruptions exceeding a certain time.

The equipment shall meet the minimum performance criteria as specified in the following clauses.

(2) Performance table

A, Performance criteria overview

Table 1: Performance criteria		
Criterion	During Test	After test (i.e. as a result of the application of the test)
A	Shall operate as intended. (see note). Shall be no loss of function. Shall be no unintentional transmissions.	Shall operate as intended. Shall be no degradation of performance. Shall be no loss of function. Shall be no loss of critical stored data.
B	May be loss of function.	Functions shall be self-recoverable. Shall operate as intended after recovering. Shall be no loss of critical stored data.
C	May be loss of function.	Functions shall be recoverable by the operator. Shall operate as intended after recovering. Shall be no loss of critical stored data.

NOTE: Operate as intended during the test allows a level of degradation in accordance with clause 6.2.2.

B, Performance criteria overview

For equipment that supports a PER or FER, the minimum performance level shall be a PER or FER less than or equal to 10 %.

For equipment that does not support a PER or a FER, the minimum performance level shall be no loss of the wireless transmission function needed for the intended use of the equipment.

(3) Performance criteria for Continuous phenomena applied to Transmitters (CT)

The performance criteria A shall apply.

Tests shall be repeated with the EUT in standby mode (if applicable) to ensure that unintentional transmission does not occur. In systems using acknowledgement signals, it is recognized that an ACKnowledgement (ACK) or Not ACKnowledgement (NACK) transmission may occur, and steps should be taken to ensure that any transmission resulting from the application of the test is correctly interpreted.

(4) Performance criteria for Transient phenomena applied to Transmitters (TT)

The performance criteria B shall apply, except for voltage dips of 100 ms and voltage interruptions of 5 000 ms duration, for which performance criteria C shall apply.

Tests shall be repeated with the EUT in standby mode (if applicable) to ensure that unintentional transmission does not occur. In systems using acknowledgement signals, it is recognized that an acknowledgement (ACK) or not-acknowledgement (NACK) transmission may occur, and steps should be taken to ensure that any transmission resulting from the application of the test is correctly interpreted.

(5) Performance criteria for Continuous phenomena applied to Receivers (CR)

The performance criteria A shall apply.

Where the EUT is a transceiver, under no circumstances, shall the transmitter operate unintentionally during the test. In systems using acknowledgement signals, it is recognized that an ACK or NACK transmission may occur, and steps should be taken to ensure that any transmission resulting from the application of the test is correctly interpreted.

(6) Performance criteria for Transient phenomena applied to Receivers (TR)

The performance criteria B shall apply, except for voltage dips of 100 ms and voltage interruptions of 5 000 ms duration for which performance criteria C shall apply.

Where the EUT is a transceiver, under no circumstances, shall the transmitter operate unintentionally during the test. In systems using acknowledgement signals, it is recognized that an ACK or NACK transmission may occur, and steps should be taken to ensure that any transmission resulting from the application of the test is correctly interpreted.

1.7 Measurement Uncertainty

The reported uncertainty of measurement $y \pm U$, where expanded uncertainty U is based on a standard uncertainty multiplied by a coverage factor of $k=2$, providing a level of confidence of approximately 95 %.

Test	Parameters	Expanded Uncertainty (U_{Lab})	Expanded Uncertainty (U_{Cispr})
Conducted Emission	Level Accuracy: 9kHz~150kHz 150kHz to 30MHz	± 3.50 dB ± 3.10 dB	± 4.0 dB ± 3.6 dB
Radiated Emission	Level Accuracy: 9kHz to 30 MHz	± 4.60 dB	N/A
Radiated Emission	Level Accuracy: 30MHz to 1000 MHz	± 4.50 dB	± 5.2 dB
Radiated Emission	Level Accuracy: Above 1000MHz	± 4.20 dB	N/A
Mains Harmonic	Voltage	$\pm 3.11\%$	N/A
Voltage Fluctuations & Flicker	Voltage	$\pm 3.25\%$	N/A

1.8 Test Facility

The testing report were performed by the Shenzhen Toby Technology Co., Ltd., in their facilities located at 1/F.,Building 6, Rundongsheng Industrial Zone, Longzhu, Xixiang, Bao'an District, Shenzhen, Guangdong, China. At the time of testing, the following bodies accredited the Laboratory:

CNAS (L5813)

The Laboratory has been accredited by CNAS to ISO/IEC 17025: 2017 General Requirements for the Competence of Testing and Calibration Laboratories for the competence in the field of testing. And the Registration No.: CNAS L5813.

A2LA Certificate No.: 4750.01

The laboratory has been accredited by American Association for Laboratory Accreditation(A2LA) to ISO/IEC 17025: 2017 General Requirements for the Competence of Testing and Calibration Laboratories for the technical competence in the field of Electrical Testing. And the A2LA Certificate No.: 4750.01.FCC Accredited Test Site Number: 854351.

IC Registration No.: (11950A)

The Laboratory has been registered by Certification and Engineering Bureau of Industry Canada for radio equipment testing. The site registration: Site# 11950A.

2 Test Results Summary

Test procedures according to the technical standards:

Requirement Standard:	ETSI EN 301 489-1 V2.2.3:2019 ETSI EN 301 489-17 V3.2.4:2020			
EMC Emission				
Test Standard	Test Item	Limit	Result	Remark
EN 55032:2015	Conducted Emission	Class B	PASS	
	Radiated Emission	Class B	PASS	
EN 61000-3-2:2014	Harmonic Current Emission	Class A	N/A	Note 2
EN 6000-3-3:2013	Voltage Fluctuations & Flicker		PASS	
EMC Immunity				
Test Standard	Test Item		Result	Remark
EN61000-4-2: 2009	Electrostatic Discharge	B (TT,TR)	PASS	
EN 61000-4-3:2006 +A1:2008+A2:2010	RF electromagnetic field	A (CT,CR)	PASS	
EN 61000-4-4:2012	Fast transients	B (TT,TR)	PASS	
EN 61000-4-5:2014	Surges	B (TT,TR)	PASS	
EN 61000-4-6: 2014	Injected Current	A (CT,CR)	PASS	
EN 61000-4-11: 2004	Volt. Interruptions Volt. Dips	B /B/ C / C NOTE (3)	PASS	
NOTE:				
	(1) " N/A" denotes test is not applicable in this Test Report			
	(2) The power consumption of EUT is less than 75W and no Limits apply.			
	(3) Voltage dip: 0% residual 0.5 cycle– Performance Criteria B (TT,TR)			
	Voltage dip: 0% residual 1 cycle– Performance Criteria B (TT,TR)			
	Voltage dip: 70% residual 25 cycles – Performance Criteria C			
	Voltage Interruption: 0% residual voltage 250 cycles – Performance Criteria C			
	<ul style="list-style-type: none"> ● in the case where the equipment is fitted with or connected to a battery back-up, the performance criteria for transient phenomena shall apply ; ● in the case where the equipment is powered solely from the AC mains supply (without the use of a parallel battery back-up) volatile user data may have been lost and if applicable the communication link need not to be maintained and lost functions should be recoverable by user or operator 			
	(4) The performance criteria for continuous phenomena shall apply(CT,CR). The performance criteria for transient phenomena shall apply (TT,TR).			

3 Test Software

Test Item	Test Software	Manufacturer	Version No.
Conducted Emission	EZ-EMC	EZ	CDI-03A2
Radiation Emission	EZ-EMC	EZ	FA-03A2RE
Voltage Fluctuation and Flicker	CTS4	CI	4.24.0
Conducted Immunity	IEC/EN 61000-6-4 Application	FRANKONIA	1.1.1
Electrical Fast Transient	lec.control	Nemtest	5.1.1.0
Surge	lec.control	Nemtest	5.1.1.0
Voltage Dip and Interruption	lec.control	Nemtest	5.1.1.0

4 Test Equipment Used

Conducted Emission Test					
Equipment	Manufacturer	Model No.	Serial No.	Last Cal.	Cal. Due Date
EMI Test Receiver	Rohde & Schwarz	ESCI	100321	Jul. 06, 2020	Jul. 05, 2021
RF Switching Unit	Compliance Direction Systems Inc	RSU-A4	34403	Jul. 06, 2020	Jul. 05, 2021
AMN	SCHWARZBECK	NNBL 8226-2	8226-2/164	Jul. 06, 2020	Jul. 05, 2021
LISN	Rohde & Schwarz	ENV216	101131	Jul. 06, 2020	Jul. 05, 2021
Radiation Emission Test					
Equipment	Manufacturer	Model No.	Serial No.	Last Cal.	Cal. Due Date
Spectrum Analyzer	Agilent	E4407B	MY45106456	Jul. 06, 2020	Jul. 05, 2021
EMI Test Receiver	Rohde & Schwarz	ESPI	100010/007	Jul. 06, 2020	Jul. 05, 2021
Bilog Antenna	ETS-LINDGREN	3142E	00117537	Mar. 01, 2020	Feb. 28, 2022
Horn Antenna	ETS-LINDGREN	3117	00143207	Mar. 01, 2020	Feb. 28, 2022
Pre-amplifier	Sonoma	310N	185903	Feb. 24, 2021	Feb. 25, 2022
Pre-amplifier	HP	8449B	3008A00849	Feb. 24, 2021	Feb. 25, 2022
Cable	HUBER+SUHNER	100	SUCOFLEX	Mar. 01, 2020	Feb. 28, 2021
Positioning Controller	ETS-LINDGREN	2090	N/A	N/A	N/A
Harmonic Current and Voltage Fluctuation and Flicker Test					
Equipment	Manufacturer	Model No.	Serial No.	Last Cal.	Cal. Due Date
Harmonic Flicker Test System	CI	5001ix-CTS-400	100321	Jul. 06, 2020	Jul. 05, 2021
5K VA	CI	500liX	59468	Jul. 06, 2020	Jul. 05, 2021

Discharge Immunity Test					
Equipment	Manufacturer	Model No.	Serial No.	Last Cal.	Cal. Due Date
ESD Tester	TESEQ	NSG437	304	Jul. 07, 2020	Jul. 06, 2021
Radiated Immunity Test					
Equipment	Manufacturer	Model No.	Serial No.	Last Cal.	Cal. Due Date
Vector Signal Generator	Agilent	E4438C	US44271917	Jul. 06, 2020	Jul. 05, 2021
Power meter	Agilent	E4419B	GB40202122	Jul. 06, 2020	Jul. 05, 2021
Power Sensor	Agilent	E9300A	MY41496625	Jul. 06, 2020	Jul. 05, 2021
Power Sensor	Agilent	E9300A	MY41496628	Jul. 06, 2020	Jul. 05, 2021
RF power Amplifier	OPHIR	5225R	1045	Jul. 06, 2020	Jul. 05, 2021
RF power Amplifier	OPHIR	5273R	1018	Jul. 06, 2020	Jul. 05, 2021
RF power Amplifier	SKET	HAP_0306G-50W	SK20140456	Jul. 06, 2020	Jul. 05, 2021
Antenna	SCHWARZBECK	STLP9128E-special	STLP9128Es#139	Jul. 06, 2020	Jul. 05, 2021
Antenna	SCHWARZBECK	STLP 9149	STLP 9149#456	Jul. 06, 2020	Jul. 05, 2021
Electrical Fast Transient/ Surge/ Voltage Dip and Interruption Test					
Equipment	Manufacturer	Model No.	Serial No.	Last Cal.	Cal. Due Date
Simulator	EMTEST	UCS500N5	V0948105575	Jul. 06, 2020	Jul. 05, 2021
Auto-transformer	EMTEST	V4780S2	0109-41	Jul. 06, 2020	Jul. 05, 2021
Coupling Clamp	EMTEST	HFK	1109-04	Jul. 06, 2020	Jul. 05, 2021
Conducted Immunity Test					
Equipment	Manufacturer	Model No.	Serial No.	Last Cal.	Cal. Due Date
RF Generator	FRANKONIA	CIT-10/75	126B1126	Jul. 06, 2020	Jul. 05, 2021
Attenuator	FRANKONIA	59-6-33	A413	Jul. 06, 2020	Jul. 05, 2021
M-CDN	LUTHI	L-801 M2/M3	2599	Jul. 06, 2020	Jul. 05, 2021
ISN	SCHWARZBECK	CAT 8158	cat5 8158-179	Jul. 06, 2020	Jul. 05, 2021
EM Injection Clamp	LUTHI	EM101	35958	Jul. 06, 2020	Jul. 05, 2021

5 Conducted Disturbance Test (AC Port)

5.1 Test Standard and Limit

5.1.1 Test Standard

ETSI EN 301 489-1 Clause 8.4
ETSI EN 301 489-17
EN 55032: 2015 Class B

5.1.2 Test Limit

Conducted Disturbance Test Limit

Frequency	Maximum RF Line Voltage (dB μ V)	
	Quasi-peak Level	Average Level
150kHz~500kHz	66 ~ 56 *	56 ~ 46 *
500kHz~5MHz	56	46
5MHz~30MHz	60	50

Remark: *Decreasing linearly with logarithm of the frequency

5.2 Test Setup

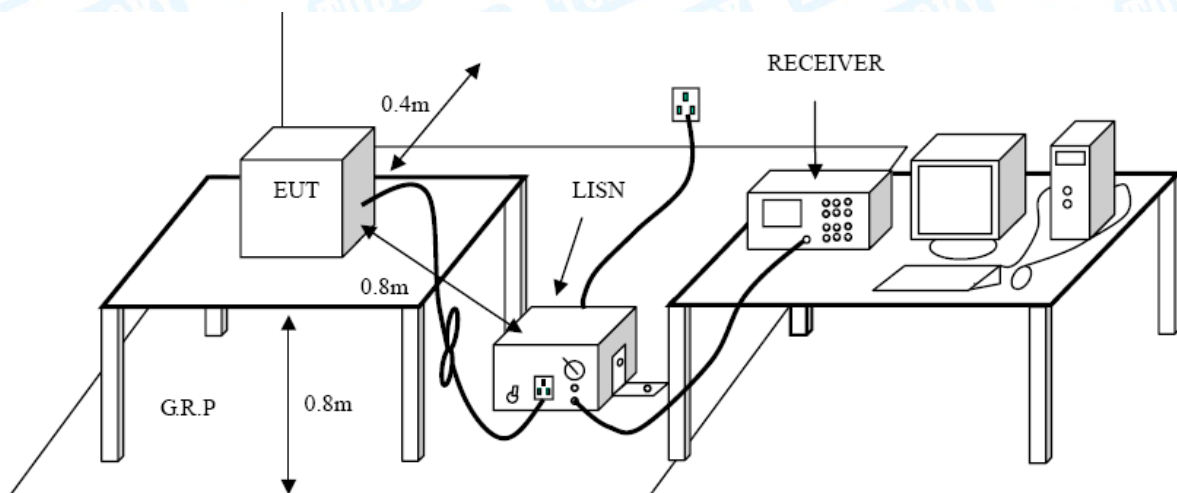

5.3 Test Procedure

The EUT was placed 0.8 meters from the horizontal ground plane with EUT being connected to the power mains through a line impedance stabilization network (LISN). All other support equipments powered from additional LISN(s). The LISN provide 50 Ohm/ 50uH of coupling impedance for the measuring instrument.

Interconnecting cables that hang closer than 40 cm to the ground plane shall be folded back and forth in the center forming a bundle 30 to 40 cm long.

I/O cables that are not connected to a peripheral shall be bundled in the center. The end of the cable may be terminated, if required, using the correct terminating impedance. The overall length shall not exceed 1 m.

LISN at least 80 cm from the nearest part of EUT chassis.

The bandwidth of EMI test receiver is set at 9kHz, and the test frequency band is from 0.15MHz to 30MHz.

5.4 Deviation From Test Standard

No deviation

5.5 Test Data

Please refer to the Attachment A.

6 CONDUCTED EMISSION (WIRED NETWORK PORT)

6.1 Test Standard and Limit

6.1.1 Test Standard

ETSI EN 301 489-1 Clause 8.7.2
EN 55032: 2015 Class B

6.1.2 Test Limit

Limits for asymmetric mode conducted emissions				
Frequency (MHz)	Class B voltage limits (dB μ V)		Class B current limits (dB μ A)	
	Quasi-peak Level	Average Level	Quasi-peak Level	Average Level
0.15 ~ 0.50	84.0~74.0	74.0~64.0	40.0~30.0	30.0~20.0
0.50 ~ 30.00	74.0	64.0	30.0	20.0

NOTE 1-The limits decrease linearly with the logarithm of the frequency in the range 0,15 MHz to 0,5 MHz.

NOTE 2-The current and voltage disturbance limits are derived for use with an impedance stabilization network (ISN) which presents a common mode (asymmetric mode) impedance of 150 Ω to the telecommunication port under test (conversion factor is $20 \log_{10} 150 / I = 44 \text{ dB}$).

6.2 Test Setup

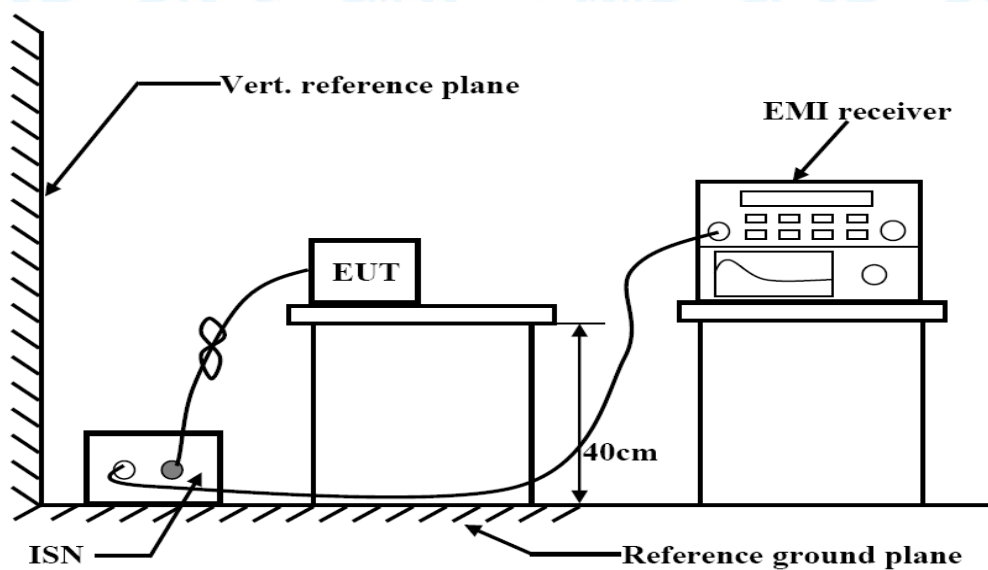

6.3 Deviation From Test Standard

No deviation

6.4 Test Data

Please refer to the Attachment B.

7 Radiated Disturbance Test

7.1 Test Standard and Limit

7.1.1 Test Standard

ETSI EN 301 489-1 Clause 8.2

ETSI EN 301 489-17

EN 55032: 2015 Class B

7.1.2 Test Limit

Radiated Disturbance Test Limit

FREQUENCY (MHz)	Class A (at 10m)	Class B (at 10m)
	dBuV/m	dBuV/m
30 – 230	40	30
230 – 1000	47	37

Notes:

- (1) The limit for radiated test was performed according to as following: EN 55032
- (2) The tighter limit applies at the band edges.
- (3) Emission level (dBuV/m)=20log Emission level (uV/m).

Limits of Radiated Emission Measurement (Above 1000MHz)

FREQUENCY (MHz)	Class A (dBuV/m) (at 3m)		Class B (dBuV/m) (at 3m)	
	PEAK	AVERAGE	PEAK	AVERAGE
1000-3000	76	56	70	50
3000-6000	80	60	74	54

Notes:

- (1) The lower limit applies at the transition frequency.

Frequency Range of Radiated Measurement

Highest frequency generated or Upper frequency of measurement used in the device or on which the device operates or tunes (MHz)	Range (MHz)
Below 108	1000
108 – 500	2000
500 – 1000	5000
Above 1000	5th harmonic of the highest frequency or 6 GHz, whichever is lower

7.2 Test Setup

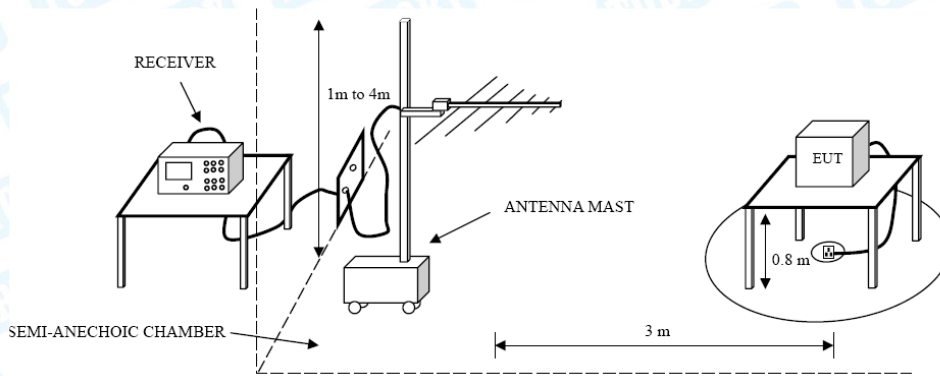

Below-1G

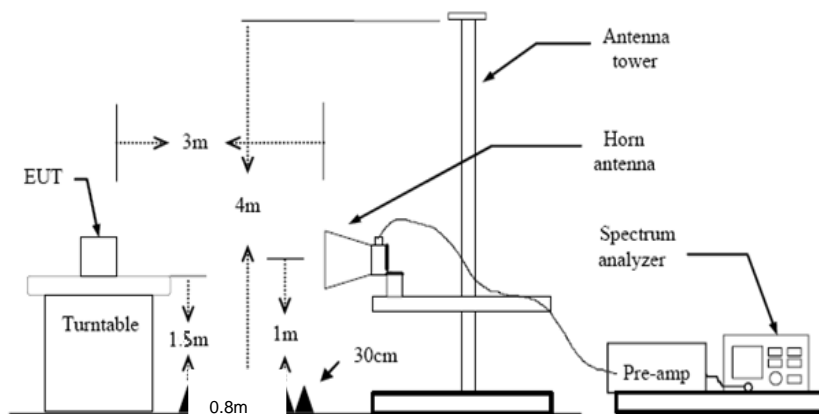

Above 1G

7.3 Test Procedure

The EUT was placed on the top of a rotating table 0.8 meters above the ground at a 3m. The table was rotated 360 degrees to determine the position of the highest radiation.

The height of the equipment or of the substitution antenna shall be 0.8 m; the height of the test antenna shall vary between 1 m to 4 m. Both horizontal and vertical polarizations of the antenna are set to make the measurement.

The initial step in collecting radiated emission data is a spectrum Quasi Peak detector mode scanning the measurement frequency range.

If the Peak Mode measured value compliance with and lower than Quasi Peak Mode Limit, the EUT shall be deemed to meet QP Limits and then no additional QP Mode measurement performed.

7.4 Deviation From Test Standard

No deviation

7.5 Test Data

Please refer to the Attachment C.

8 Harmonic Current Emission Test

8.1 Test Standard and Limit

8.1.1 Test Standard

ETSI EN 301 489-1 Clause 8.5
 ETSI EN 301 489-17
 EN IEC 61000-3-2

8.1.2 Limits

Limits for Class A equipment				Limits for Class D equipment		
Odd Harmonics		Even Harmonics		Harmonic Order (n)	Maximum Permissible Harmonic Current per watt (mA/W)	Maximum Permissible Harmonic Current (A)
Harmonic Order (n)	Maximum permissible harmonic Current (A)	Harmonic Order (n)	Maximum permissible harmonic Current (A)			
3	2.30	2	1.08	3	3.4	2.30
5	1.14	4	0.43	5	1.9	1.14
7	0.77	6	0.30	7	1.0	0.77
9	0.40	8 ≤ n ≤ 40	0.23X8/n	9	0.5	0.40
11	0.33			11	0.35	0.33
13	0.21			15 ≤ n ≤ 39 (odd harmonics only)	3.85/n	0.15X15/n
15 ≤ n ≤ 39	0.15X15/n					

8.2 Test Setup

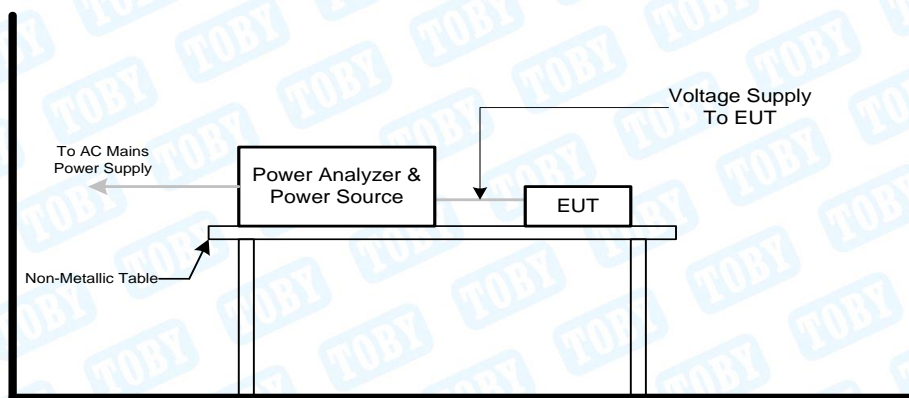

8.3 Test Procedure

The EUT was placed on the top of a wooden table 0.8 meters above the ground and operated to produce the maximum harmonic components under normal operating conditions.

The classification of EUT is according to section 5 of EN 61000-3-2. The EUT is classified as follows:

Class A: Balanced three-phase equipment, Household appliances excluding equipment as Class D, Tools excluding portable tools, Dimmers for incandescent lamps, audio equipment, equipment not specified in one of the three other classes.

Class D: Equipment having a specified power less than or equal to 600 W of the following types: Personal computers and personal computer monitors and television receivers.

8.4 Deviation From Test Standard

No deviation

8.5 Test Data

The power consumption of EUT is less than 75W and no Limits apply.

9 Voltage Fluctuation and Flicker Test

9.1 Test Standard and Limit

9.1.1 Test Standard

ETSI EN 301 489-1 Clause 8.6
ETSI EN 301 489-17
EN 61000-3-3

9.1.2 Limit

Flicker Test Limit

Test Items	Limits
Pst	1.0
dc	3.3%
dmax	4.0%
dt	Not exceed 3.3% for 500ms

9.2 Test Setup

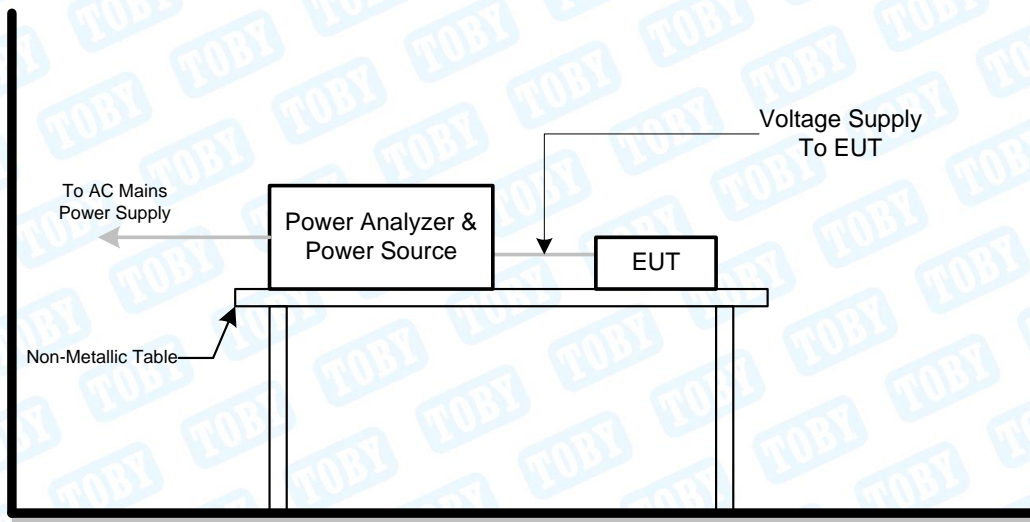

9.3 Test Procedure

Fluctuation and Flickers Test:

Tests was performed according to the Test Conditions/Assessment of Voltage Fluctuations specified in Clause 5.0/6.0 of IEC555-3 and/or Clause 6.0/4.0 of IEC/EN 61000-3-3 depend on which standard adopted for compliance measurement.

All types of harmonic current and/or voltage fluctuation in this report are assessed by direct measurement using flicker-meter.

For the actual test configuration, please refer to the related Item–Block Diagram of system tested.

9.4 Deviation From Test Standard

No deviation

9.5 Test Data

Please refer to the Attachment D.

10 Electrostatic Discharge Immunity Test

10.1 Test Requirements

10.1.1 Test Standard

ETSI EN 301 489-1 Clause 9.3
ETSI EN 301 489-17
EN 61000-4-2

10.1.2 Test Level

Discharge Impedance:	330 ohm/ 150pF
Discharge Voltage:	Air Discharge: 2kV/4kV/8kV(Direct) Contact Discharge: 2kV/4kV (Direct /Indirect)
Polarity:	Positive& Negative
Discharge Mode:	Single Discharge
Discharge Period:	1 second minimum

10.2 Test Setup

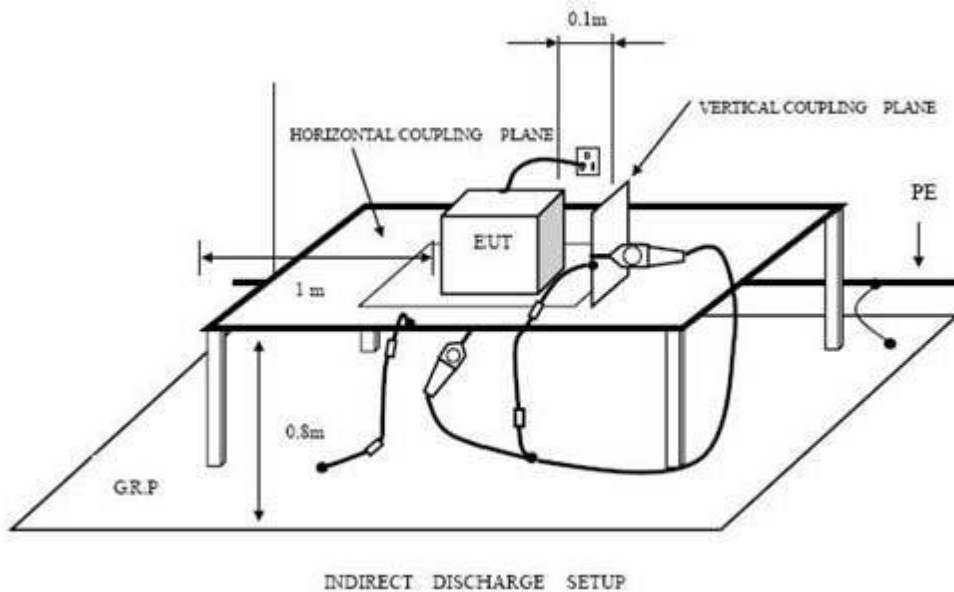

10.3 Test Procedure

The test method shall be in accordance with CENELEC EN 61000-4-2 [2], clauses 6, 7 and 8.

For radio equipment and ancillary equipment the following requirements and evaluation of test results shall apply.

The test severity level for contact discharge shall be ± 4 kV and for air discharge ± 8 kV. All other details, including intermediate test levels, are contained within CENELEC EN 61000-4-2 [2], clause 5.

Electrostatic discharges shall be applied to all exposed surfaces of the EUT except where the user documentation specifically indicates a requirement for appropriate protective measures (as specified in CENELEC EN 61000-4-2 [2], clauses 8.3.2 and 8.3.3).

10.4 Deviation From Test Standard

No deviation

10.5 Test Data

Please refer to the Attachment E.

11 Radiated Electromagnetic Field Immunity test

11.1 Test Requirements

11.1.1 Test Standard

ETSI EN 301 489-1 Clause 9.2
ETSI EN 301 489-17
EN 61000-4-3

11.1.2 Test Level

Test Level for Radiated Electromagnetic Field Immunity Test

Port	Test Specification
Enclosure Port	80-6000MHz 3 V/m 80 % AM (1kHz)

11.2 Test Setup

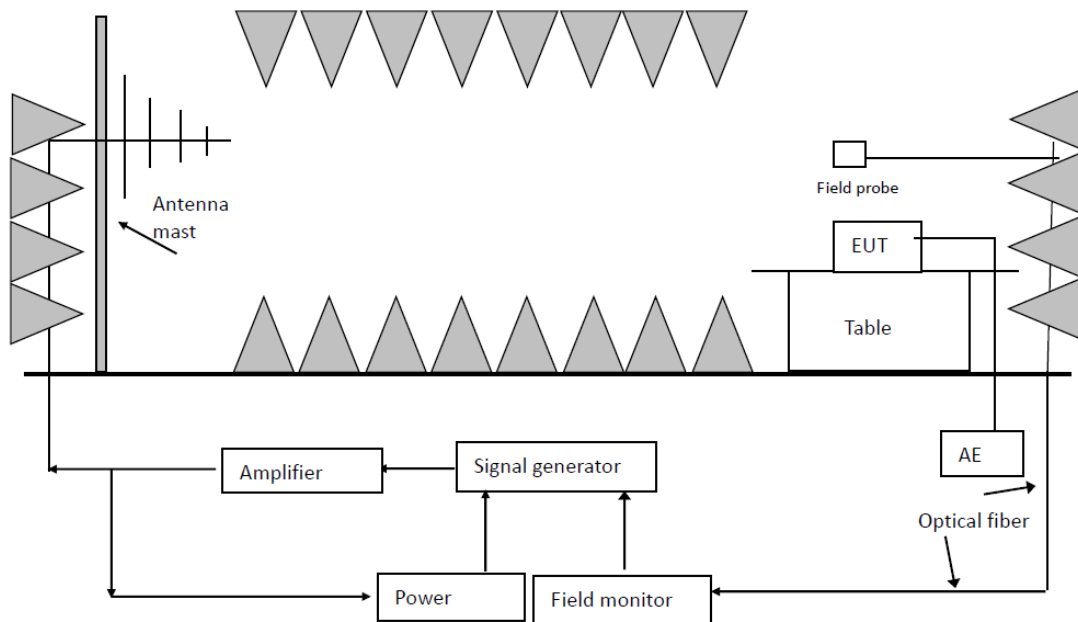

11.3 Test Procedure

The test method shall be in accordance with CENELEC EN 61000-4-3 [3], clauses 6, 7 and 8.

The following requirements and evaluation of test results shall apply:

- the test level shall be 3 V/m (measured unmodulated). The test signal shall be amplitude modulated to a depth of 80 % by a sinusoidal audio signal of 1 000 Hz. If the wanted signal is modulated at 1 000 Hz, then an audio signal of 400 Hz shall be used;
- the test shall be performed over the frequency range 80 MHz to 6 000 MHz with the exception of the exclusion band for transmitters, receivers and duplex transceivers (see clause 4.3), as appropriate;
- for receivers and transmitters the stepped frequency increments shall be 1 % frequency increment of the momentary used frequency;
- the dwell time of the test phenomena at each frequency shall not be less than the time necessary for the EUT to be exercised and to be able to respond;

NOTE: Dwell time is product dependent.

- the frequencies selected and used during the test shall be recorded.

All the scanning conditions are as following:

Condition of Test	Remark
Fielded Strength	3V/m
Radiated Signal	80%AM, 1kHz Since Wave
Scanning Frequency	80-6000MHz

Note:

The exclusion band for immunity testing of equipment operating in the 2,4 GHz band shall be:

- lower limit of exclusion band = lowest allocated band edge frequency -120 MHz, i.e. 2 280 MHz;
- upper limit of exclusion band = highest allocated band edge frequency +120 MHz, i.e. 2 603,5MHz.

The exclusion band for immunity testing of equipment operating in the 5 GHz Wi-Fi band shall be:

- lower limit of exclusion band = lowest allocated band edge frequency -270 MHz, i.e. 4 880 MHz;
- upper limit of exclusion band = highest allocated band edge frequency +270 MHz, i.e. 5 995 MHz.

11.4 Deviation From Test Standard

No deviation

11.5 Test Data

Please refer to the Attachment F.

12 Electrical Fast Transient/Burst Test

12.1 Test Requirements

12.1.1 Test Standard

ETSI EN 301 489-1 Clause 9.4
ETSI EN 301 489-17
EN 61000-4-4

12.1.2 Test Level

Test Level for Electrical Fast Transient Test

	On Switching Adapter Lines	On I/O (Input/Output) Signal data and control lines
Test Voltage:	1 KV	0.5 KV
Polarity:	Positive & Negative	
Impulse Wave Shape:	5/50ns	
Burst Duration:	15ms	
Burst Period:	300ms	
Test Duration:	Not less than 1 min	

12.2 Test Setup

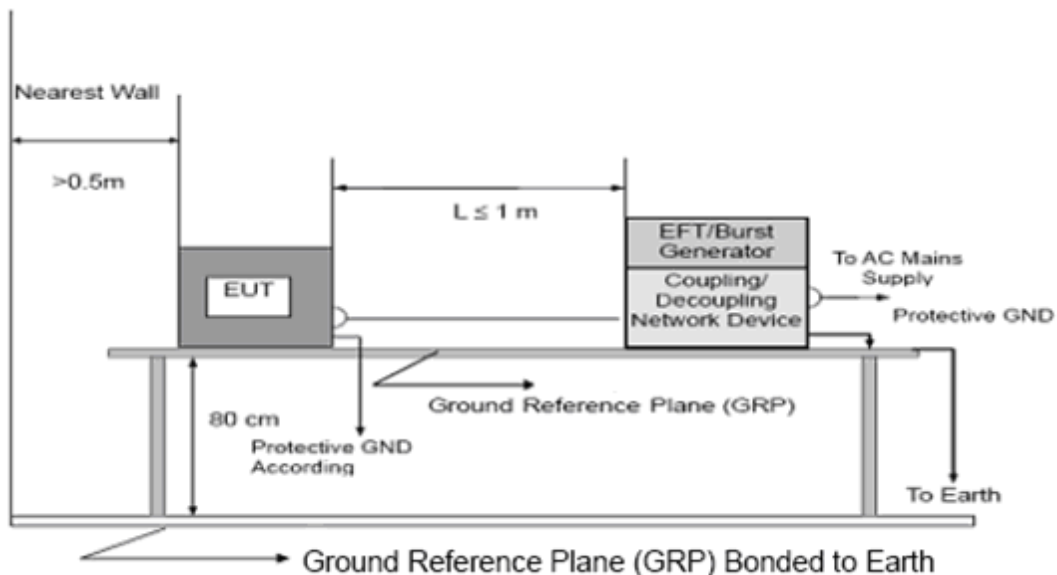

12.3 Test Procedure

The test method shall be in accordance with CENELEC EN 61000-4-4 [4], clauses 7 and 8.

The following requirements and evaluation of test results shall apply:

- the test level for signal ports, wired network ports (excluding xDSL), and control ports shall be 0,5 kV open circuit voltage at a repetition rate of 5 kHz as given in CENELEC EN 61000-4-4 [4], clause 5;
- the test level for xDSL wired network ports shall be 0,5 kV open circuit voltage at a repetition rate of 100 kHz as given in CENELEC EN 61000-4-4 [4], clause 5;
- the test level for DC power input ports shall be 0,5 kV open circuit voltage at a repetition rate of 5 kHz as given CENELEC EN 61000-4-4 [4], clause 5;
- the test level for AC mains power input ports shall be 1 kV open circuit voltage at a repetition rate of 5 kHz as given CENELEC EN 61000-4-4 [4], clause 5.

12.4 Deviation From Test Standard

No deviation

12.5 Test Data

Please refer to the Attachment G.

13 Surge Immunity Test

13.1 Test Requirements

13.1.1 Test Standard

ETSI EN 301 489-1 Clause 9.8
ETSI EN 301 489-17
EN 61000-4-5

13.1.2 Level

Test Level for Surge Immunity Test

Basic Standard:	EN 61000-4-5
Test Requirement:	Analogue/digital data ports: 1KV (see a)
	DC network power ports: 0.5KV
	AC mains power ports: 1KV(Line-Line), 2KV(Line-earth)
T_r/T_h	1.2/50us, 10/700us
Generator Source:	2 ohm between networks
Impedance:	12 ohm between network and ground
Polarity:	Positive/Negative
Phase Angle:	0/90/180/270
Pulse Repetition Rate:	1 time/min.(maximum)
Number of Tests:	5 positive and 5 negative at selected points
a: Port type: coaxial or shielded. Apply: shield to ground.	

Performance criterion: B

13.2 Test Setup

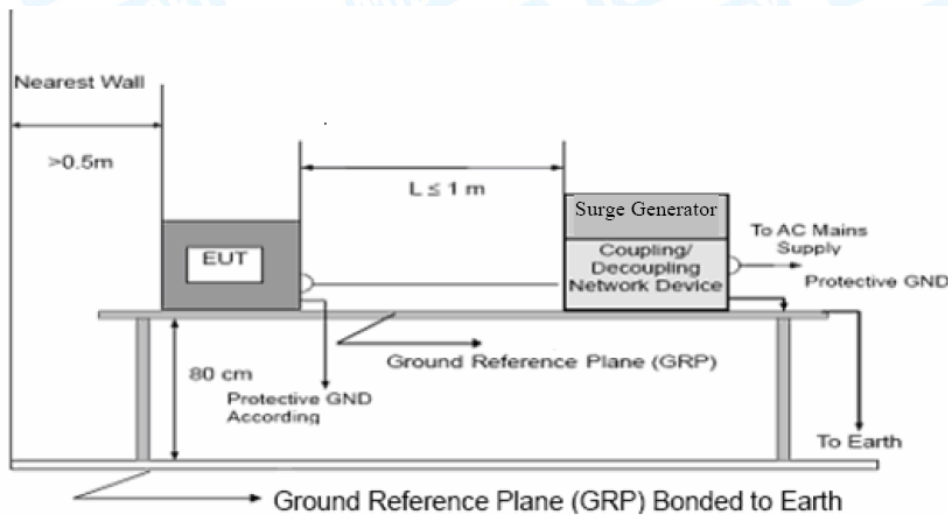

13.3 Test Procedure

The test method shall be in accordance with CENELEC EN 61000-4-5 [5], clauses 7 and 8.

The requirements and evaluation of test results given in clause 9.8.2.1 (wired network ports, outdoor cables), clause 9.8.2.2 (wired network ports, indoor cables) and clause 9.8.2.3 (mains ports) shall apply, but no test shall be required where normal functioning cannot be achieved, because of the impact of the CDN on the EUT.

13.4 Deviation From Test Standard

No deviation

13.5 Test Data

Please refer to the Attachment H.

14 RF Common Mode

14.1 Test Requirements

14.1.1 Test Standard

ETSI EN 301 489-1 Clause 9.5
ETSI EN 301 489-17
EN 61000-4-6

14.1.2 Test Level

Test Level for RF Common Mode

Port	Test Specification
Input AC power port	0.15MHz~80MHz 3V(r.m.s.) (unmodulated)

Performance criterion: A

14.2 Test Setup

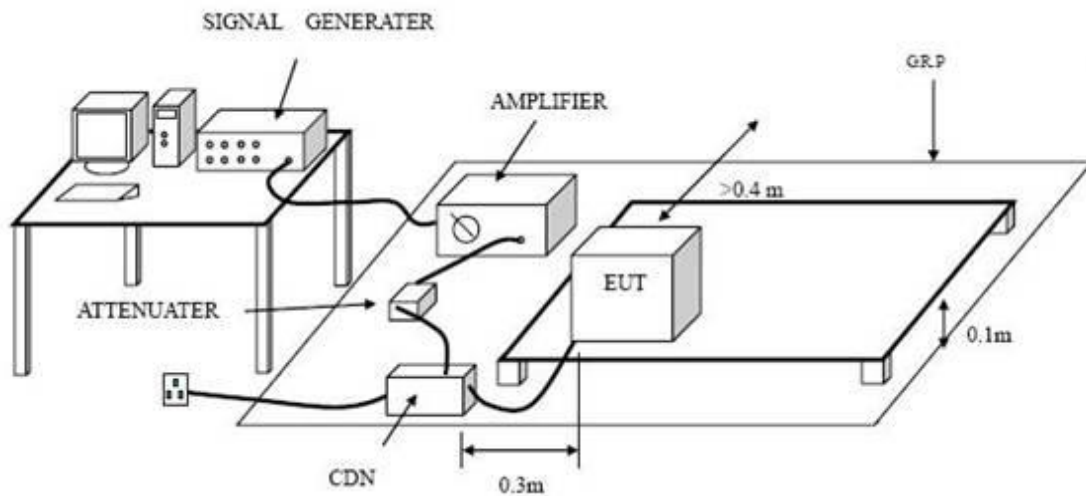

14.3 Test Procedure

The following requirements and evaluation of test results shall apply:

- the test level shall be severity level 2 as given in CENELEC EN 61000-4-6 [6], clause 5 corresponding to 3 V rms unmodulated. The test signal shall then be amplitude modulated to a depth of 80 % by a sinusoidal audio signal of 1 000 Hz. If the wanted signal is modulated at 1 000 Hz, then the test signal of 400 Hz shall be used;
- the test shall be performed over the frequency range 150 kHz to 80 MHz with the exception of an exclusion band for transmitters, and for receivers and duplex transceivers, (see clause 4.3);
- for receivers and transmitters the stepped frequency increments shall be 1 % frequency increment of the momentary frequency in the frequency range 150 kHz to 80 MHz;
- the injection method to be used shall be selected according to the basic standard CENELEC EN 61000-4-6 [6], clause 7;
- responses on receivers or receiver parts of transceivers occurring at discrete frequencies which are narrow band responses (spurious responses), are disregarded from the test (as specified in clause 4); the dwell time of the test phenomena at each frequency shall not be less than the time necessary for the EUT to be exercised and to be able to respond;
- the frequencies of the immunity test signal selected and used during the test shall be recorded.

14.4 Deviation From Test Standard

No deviation

14.5 Test Data

Please refer to the Attachment I.

15 Voltage Dips and Interruptions Immunity Test

15.1 Test Requirements

15.1.1 Test Standard

ETSI EN 301 489-1 Clause 9.7
ETSI EN 301 489-17
EN 61000-4-11

15.1.2 Level

Test Level for Voltage Dips and Interruptions

Basic Standard:	EN 61000-4-11
Required Performance:	B(For 100% Voltage Dips) B(For 100% Voltage Dips) C(For 30% Voltage Dips) C(For 100% Voltage Interruptions)
Test Duration Time:	Minimum three test events in sequence
Interval Between Event:	Minimum ten seconds
Phase Angle:	0°/45°/90°/135°/180°/225°/270°/315°/360°
Test Cycle:	3 times

15.2 Test Setup

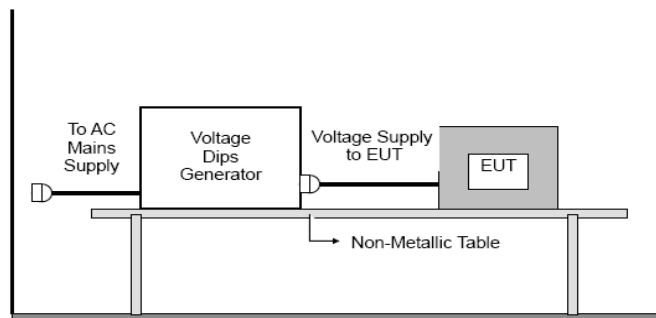

15.3 Test Procedure

The following requirements and evaluation of test results shall apply. The test method shall be in accordance with CENELEC EN 61000-4-11 [7], clause 8 or for equipment requiring a mains current of greater than 16 A CENELEC EN 61000-4-34 [16], clause 8 shall be used.

The test levels shall be:

- voltage dip: 0 % residual voltage for 0,5 cycle;
- voltage dip: 0 % residual voltage for 1 cycle;
- voltage dip: 70 % residual voltage for 25 cycles (at 50 Hz);
- voltage interruption: 0 % residual voltage for 250 cycles (at 50 Hz).

15.4 Deviation From Test Standard

No deviation

15.5 Test Data

Please refer to the Attachment J.

16 Photographs - Constructional Details

Photo 1 Appearance of EUT



Photo 2 Appearance of EUT



Photo 3 Appearance of EUT



Photo 4 Appearance of PCB



Photo 5 Appearance of PCB



Photo 6 Appearance of PCB



Photo 7 Appearance of PCB



Photo 8 Internal of EUT

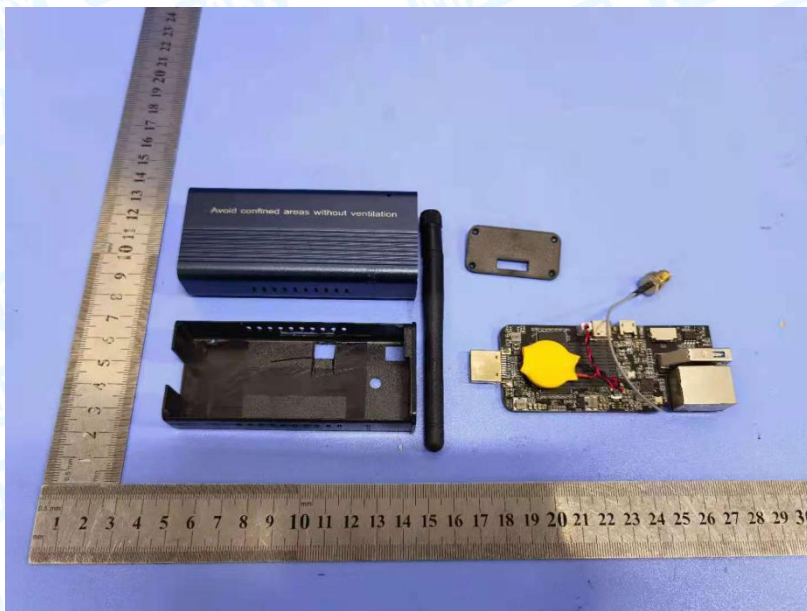

Photo 9 Appearance of PCB

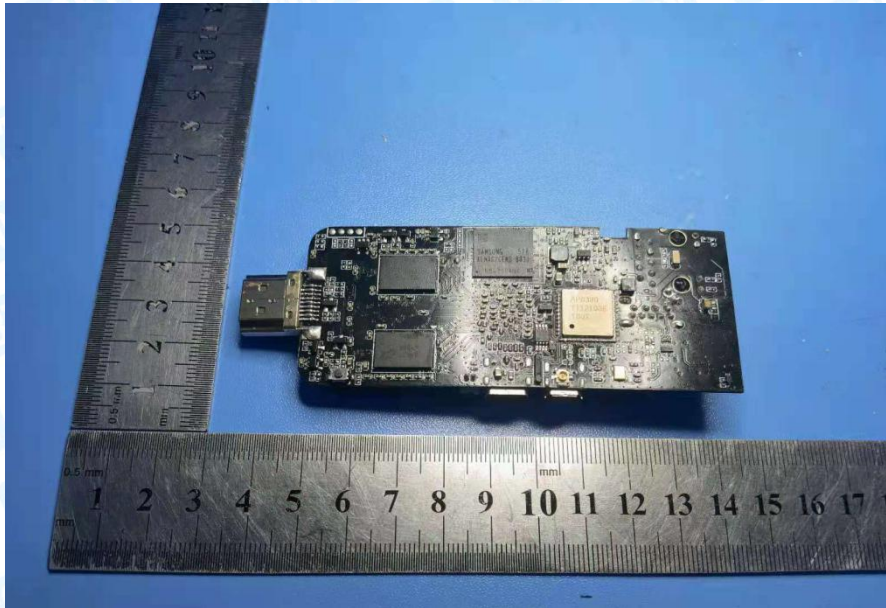

Photo 10 Appearance of PCB

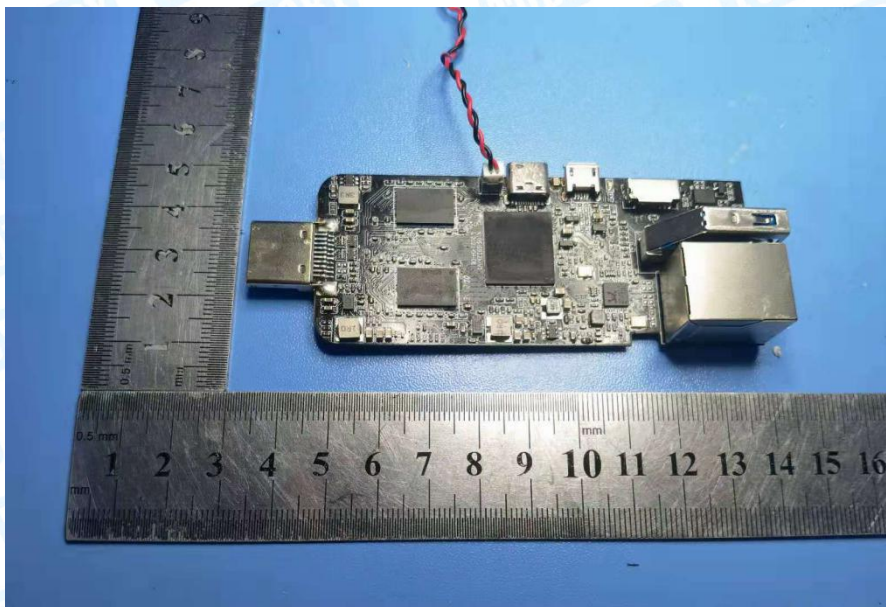
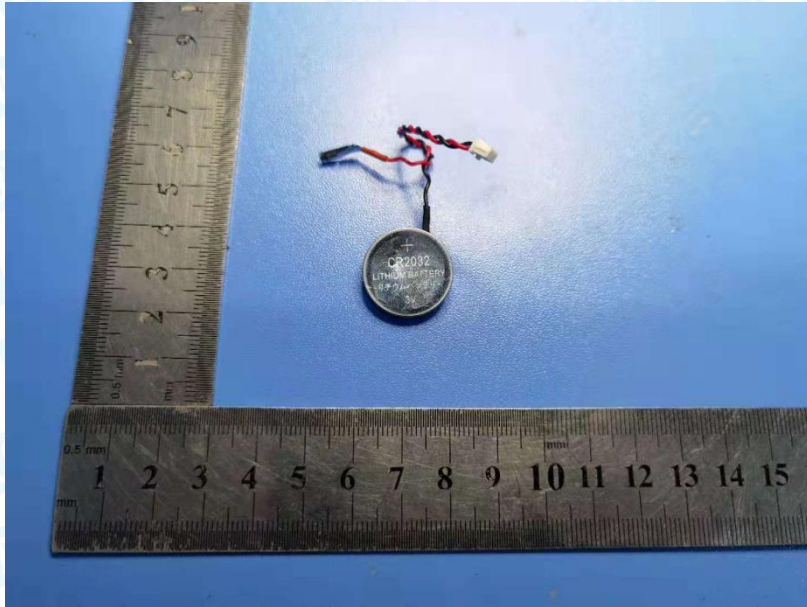

Photo 11 Battery Parameters



17 Photographs –Test Setup

Conducted Emission Test Setup



Radiated Emission Test Setup-Below 1G



Radiated Emission Test Setup-Above 1G



Harmonic current emissions and Voltage fluctuations & flicker Test Setup



Electrostatic Discharge Test Setup

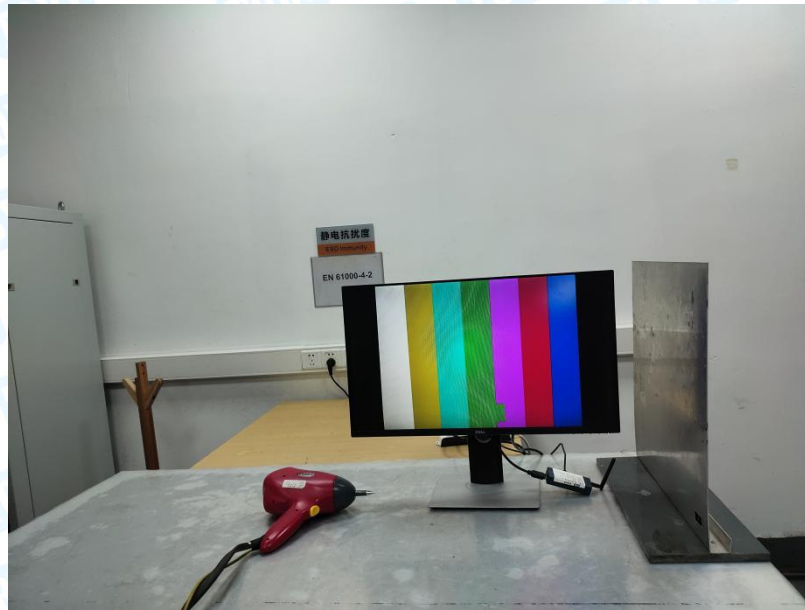

EFT, Surge, Voltage Dips Test Setup

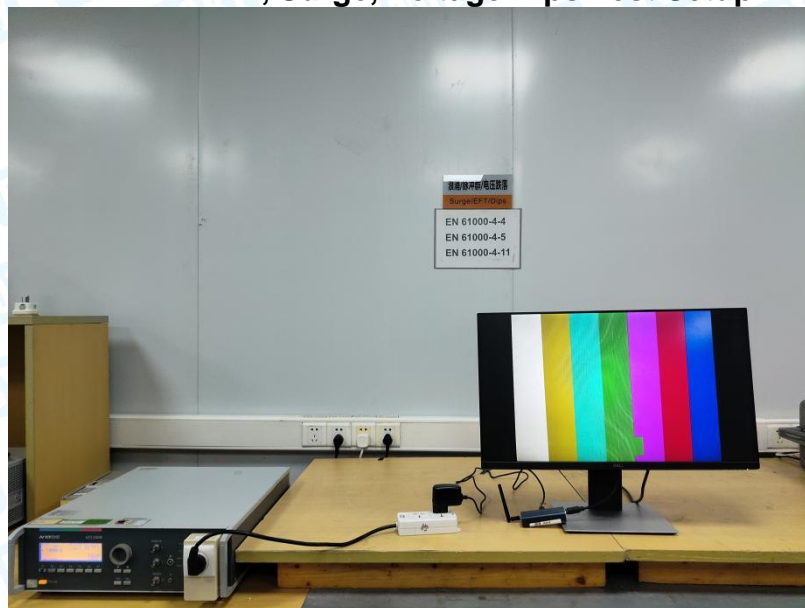

Radio-frequency, Continuous Conducted Disturbance Test Setup



Attachment A--Conducted Emission Data (AC Mains)

Temperature:	24.6°C	Relative Humidity:	42%
Pressure:	1010 hPa		
Test Voltage:	AC 230V/50 Hz		
Terminal:	Line		
Test Mode:	Mode 7		
Remark:	Only showed test data of the worst mode		

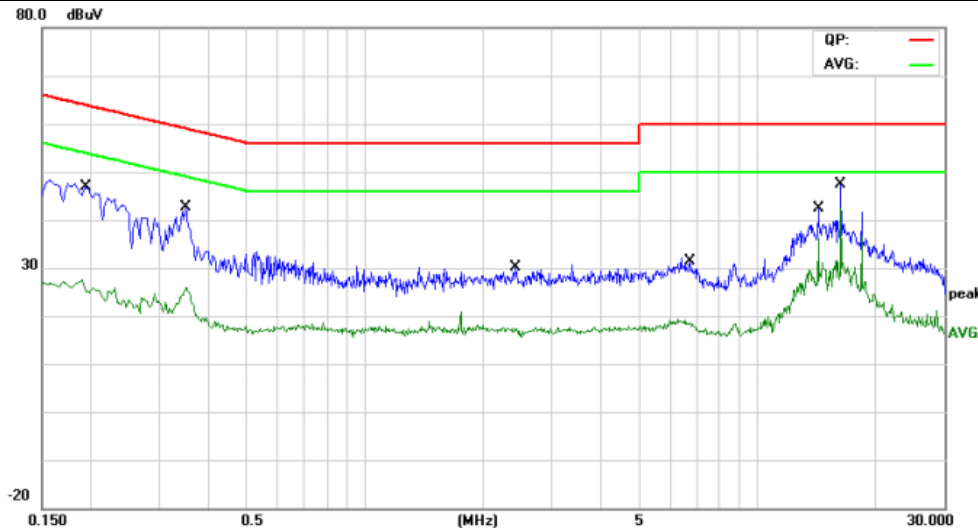

No. Mk.	Freq. MHz	Reading Level dBuV	Correct Factor dB	Measurement dBuV	Limit dBuV	Over dB	Detector
1	0.1940	30.46	9.80	40.26	63.86	-23.60	QP
2	0.1940	14.03	9.80	23.83	53.86	-30.03	AVG
3	0.3500	24.60	9.80	34.40	58.96	-24.56	QP
4	0.3500	15.36	9.80	25.16	48.96	-23.80	AVG
5	2.4140	11.80	9.80	21.60	56.00	-34.40	QP
6	2.4140	6.37	9.80	16.17	46.00	-29.83	AVG
7	6.7460	14.13	9.89	24.02	60.00	-35.98	QP
8	6.7460	7.60	9.89	17.49	50.00	-32.51	AVG
9	14.3380	31.32	9.99	41.31	60.00	-18.69	QP
10	14.3380	25.95	9.99	35.94	50.00	-14.06	AVG
11	16.3860	34.96	10.00	44.96	60.00	-15.04	QP
12 *	16.3860	32.11	10.00	42.11	50.00	-7.89	AVG

Remark:

1. Corr. Factor (dB) = LISN Factor (dB) + Cable Loss (dB)

2. Margin (dB) = QuasiPeak/Average (dBuV) - Limit (dBuV) Note: For conducted emission and radiated emission test, a power supply of 230VAC and 120VAC was used for testing respectively, and only recorded the worst case of 230VAC.

Temperature:	24.6°C	Relative Humidity:	42%
Pressure:	1010 hPa		
Test Voltage:	AC 230V/50 Hz		
Terminal:	Neutral		
Test Mode:	Mode 7		
Remark:	Only showed test data of the worst mode		

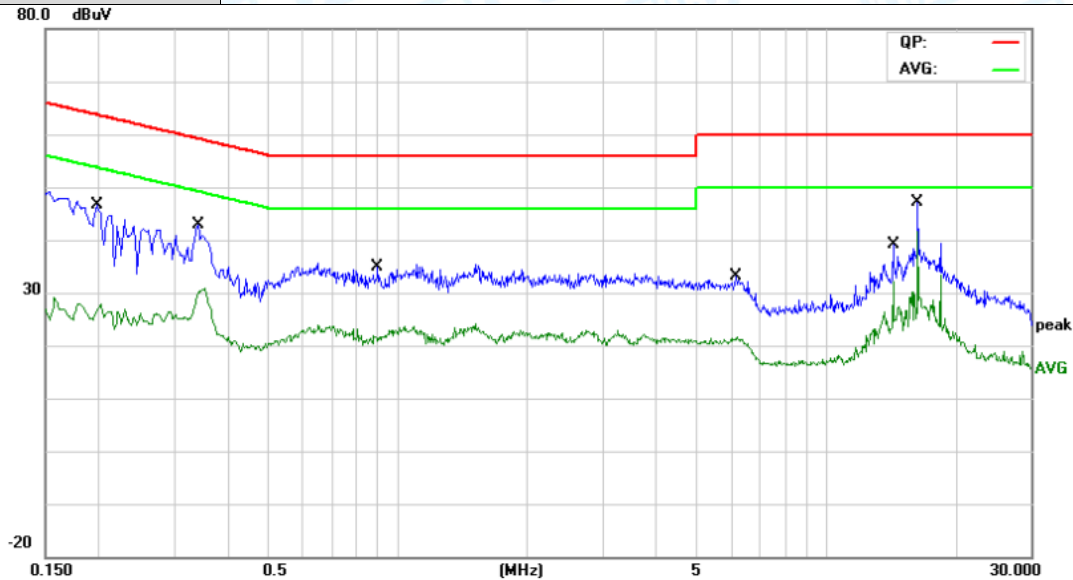

No.	Mk.	Freq.	Reading Level	Correct Factor	Measurement	Limit	Over	Detector
		MHz	dBuV	dB	dBuV	dBuV	dB	
1		0.1980	29.62	9.80	39.42	63.69	-24.27	QP
2		0.1980	14.85	9.80	24.65	53.69	-29.04	AVG
3		0.3420	27.33	9.80	37.13	59.15	-22.02	QP
4		0.3420	19.89	9.80	29.69	49.15	-19.46	AVG
5		0.8980	18.20	9.80	28.00	56.00	-28.00	QP
6		0.8980	11.34	9.80	21.14	46.00	-24.86	AVG
7		6.1660	17.34	9.86	27.20	60.00	-32.80	QP
8		6.1660	10.85	9.86	20.71	50.00	-29.29	AVG
9		14.3380	27.27	9.99	37.26	60.00	-22.74	QP
10		14.3380	22.57	9.99	32.56	50.00	-17.44	AVG
11		16.3860	34.29	10.00	44.29	60.00	-15.71	QP
12	*	16.3860	30.24	10.00	40.24	50.00	-9.76	AVG

Remark:

1. Corr. Factor (dB) = LISN Factor (dB) + Cable Loss (dB)

2. Margin (dB) = QuasiPeak/Average (dBuV) - Limit (dBuV)

Note: For conducted emission and radiated emission test, a power supply of 230VAC and 120VAC was used for testing respectively, and only recorded the worst case of 230VAC.

Attachment B--Conducted Emission Data (WIRED NETWORK PORT)

Temperature:	24.6°C	Relative Humidity:	42%
Pressure:	1010 hPa		
Test Voltage:	AC 230V/50 Hz		
Test Mode:	Mode 1		
Remark:	Only showed test data of the worst mode		

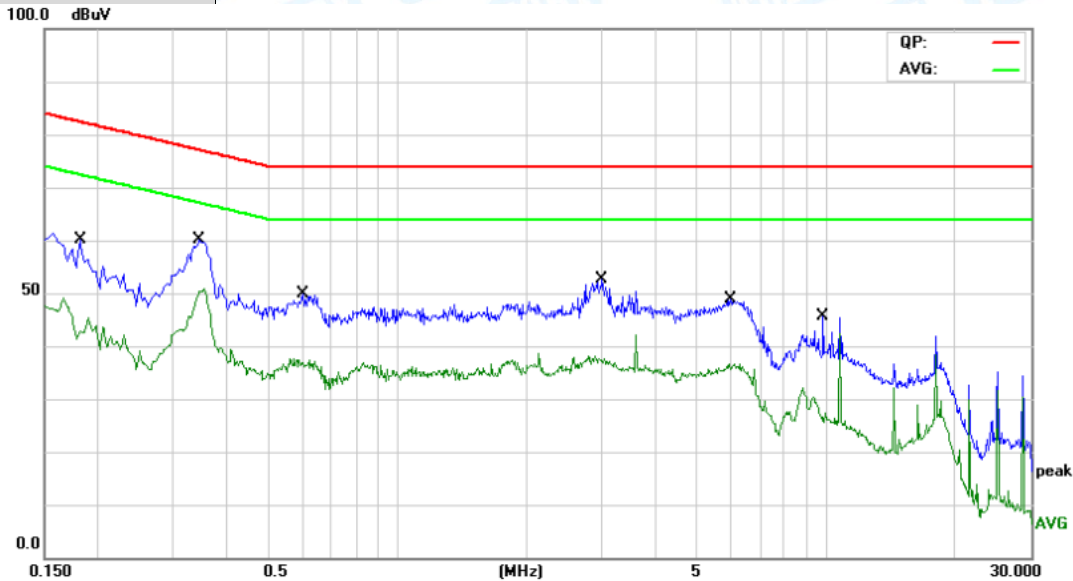

No.	Mk.	Freq.	Reading Level	Correct Factor	Measurement	Limit	Over	Detector
		MHz	dBuV	dB	dBuV	dBuV	dB	
1		0.1819	42.60	9.81	52.41	82.39	-29.98	QP
2		0.1819	30.18	9.81	39.99	72.39	-32.40	AVG
3		0.3460	48.21	9.77	57.98	77.06	-19.08	QP
4	*	0.3460	40.48	9.77	50.25	67.06	-16.81	AVG
5		0.6020	34.83	9.66	44.49	74.00	-29.51	QP
6		0.6020	26.76	9.66	36.42	64.00	-27.58	AVG
7		2.9980	36.38	9.60	45.98	74.00	-28.02	QP
8		2.9980	27.28	9.60	36.88	64.00	-27.12	AVG
9		5.9820	34.43	9.63	44.06	74.00	-29.94	QP
10		5.9820	25.84	9.63	35.47	64.00	-28.53	AVG
11		9.8180	23.75	9.67	33.42	74.00	-40.58	QP
12		9.8180	15.80	9.67	25.47	64.00	-38.53	AVG

Remark:

1. Corr. Factor (dB) = LISN Factor (dB) + Cable Loss (dB)

2. Margin (dB) = QuasiPeak/Average (dBuV) - Limit (dBuV)

Attachment B--Radiated Emission Test Data

-----Below 1G

Temperature:	24.5°C	Relative Humidity:	43.6%
Pressure:	1010 hPa		
Test Voltage:	AC 230V/50Hz		
Ant. Pol.	Horizontal		
Test Mode:	Mode 7		
Remark:	Only showed test data of the worst mode		

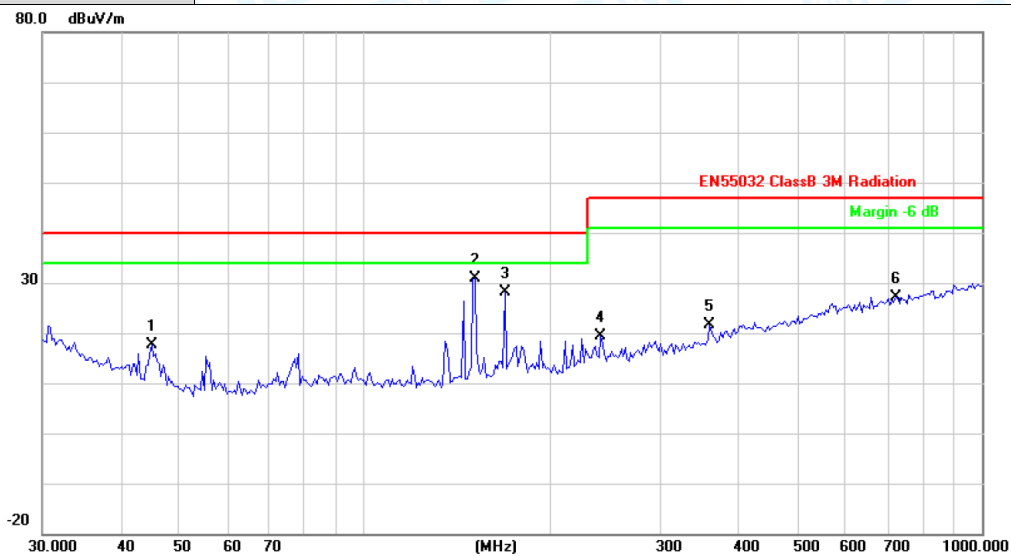

No.	Mk.	Freq. MHz	Reading Level dBuV	Correct Factor dB/m	Measure- ment dBuV/m	Limit dBuV/m	Over dB	Detector
1		45.0583	39.11	-21.44	17.67	40.00	-22.33	peak
2	*	150.5378	52.15	-21.31	30.84	40.00	-9.16	peak
3		168.4138	48.73	-20.52	28.21	40.00	-11.79	peak
4		240.8304	37.20	-17.72	19.48	47.00	-27.52	peak
5		361.7139	35.82	-14.09	21.73	47.00	-25.27	peak
6		724.2611	33.82	-6.68	27.14	47.00	-19.86	peak

Remark:

- 1. Corr. = Antenna Factor (dB/m) + Cable Loss (dB)
- 2. QuasiPeak (dBuV/m)= Corr. (dB/m)+ Read Level (dBuV)
- 3. Margin (dB) = QuasiPeak (dBuV/m)-Limit QPK(dBuV/m)

Temperature:	24.5°C	Relative Humidity:	43.6%
Pressure:	1010 hPa		
Test Voltage:	AC 230V/50Hz		
Ant. Pol.	Vertical		
Test Mode:	Mode 2		
Remark:	Only showed test data of the worst mode		

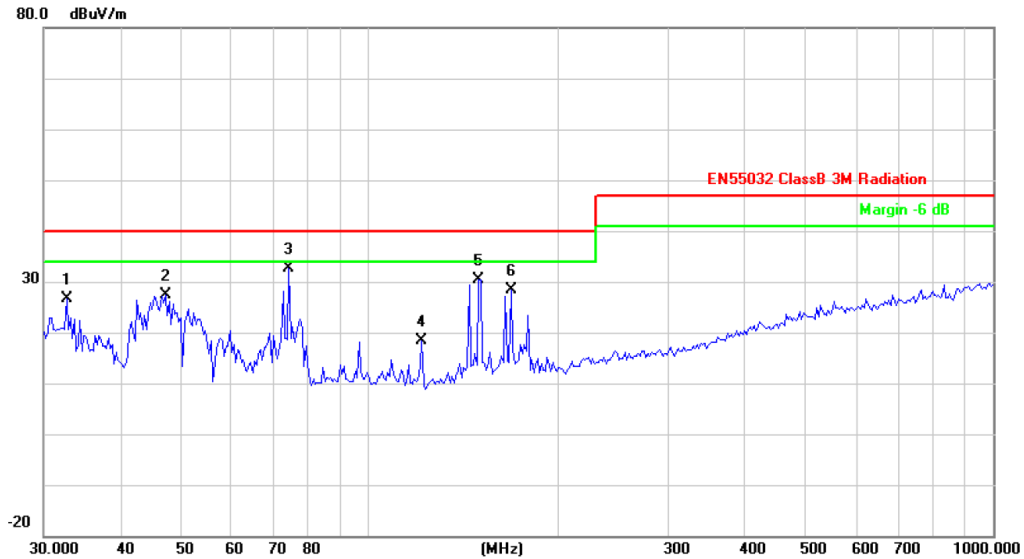

No.	Mk.	Freq. MHz	Reading Level dBuV	Correct Factor dB/m	Measure- ment dBuV/m	Limit dBuV/m	Over dB	Detector
1		32.6340	41.64	-14.91	26.73	40.00	-13.27	peak
2		46.9948	49.49	-22.07	27.42	40.00	-12.58	peak
3	*	74.1351	55.65	-23.01	32.64	40.00	-7.36	peak
4		121.1231	40.48	-22.18	18.30	40.00	-21.70	peak
5		149.4857	51.89	-21.40	30.49	40.00	-9.51	peak
6		168.4138	48.79	-20.52	28.27	40.00	-11.73	peak

Remark:

- 1. Corr. = Antenna Factor (dB/m) + Cable Loss (dB)
- 2. QuasiPeak (dBuV/m) = Corr. (dB/m) + Read Level (dBuV)
- 3. Margin (dB) = QuasiPeak (dBuV/m) - Limit QPK (dBuV/m)

-----Above 1G

Temperature:	24.5°C	Relative Humidity:	43.6%
Pressure:	1010 hPa		
Test Voltage:	AC 230V/50Hz		
Ant. Pol.	Horizontal		
Test Mode:	Mode 1		
Remark:	No report for the emission which more than 20 dB below the prescribed limit.		

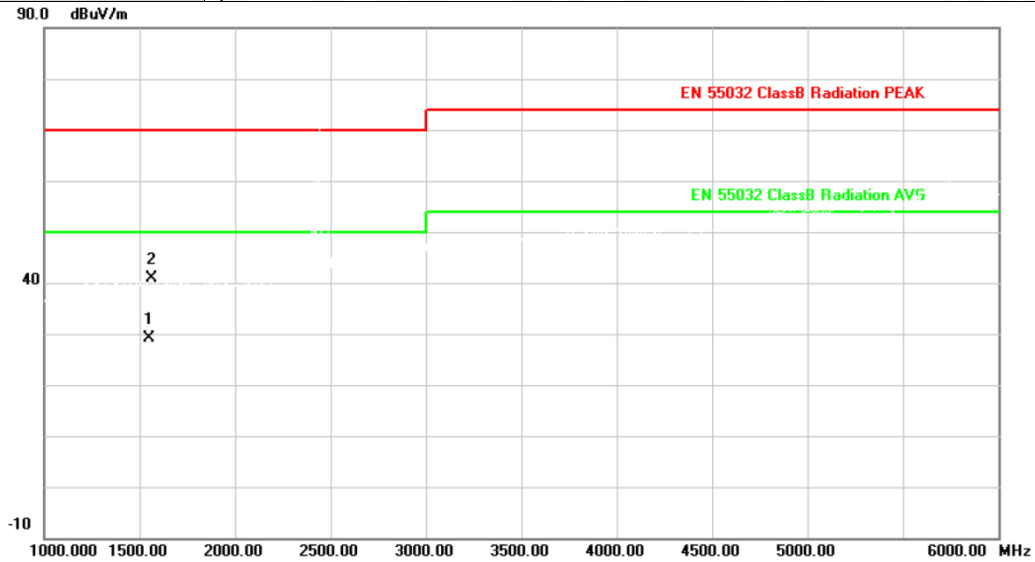

No.	Mk.	Freq. MHz	Reading Level dBuV	Correct Factor dB/m	Measure- ment dBuV/m	Limit dBuV/m	Over dB	Detector
1	*	1551.680	31.19	-2.15	29.04	50.00	-20.96	AVG
2		1560.000	43.08	-2.14	40.94	70.00	-29.06	peak

Remark:

1. Corr. = Antenna Factor (dB/m) + Cable Loss (dB)
2. Peak/AVG (dBμV/m) = Corr. (dB/m) + Read Level (dBμV)
3. Margin (dB) = Peak/AVG (dBμV/m) - Limit PK/AVG (dBμV/m)

Temperature:	24.5°C	Relative Humidity:	43.6%
Pressure:	1010 hPa		
Test Voltage:	AC 230V/50Hz		
Ant. Pol.	Vertical		
Test Mode:	Mode 1		
Remark:	No report for the emission which more than 20 dB below the prescribed limit.		

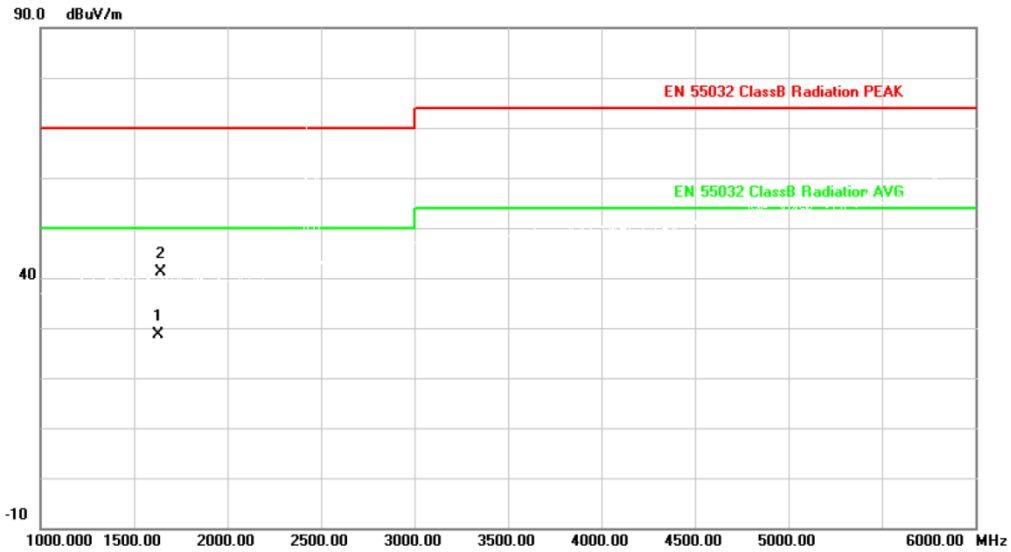

No.	Mk.	Freq. MHz	Reading Level dBuV	Correct Factor dB/m	Measure- ment dBuV/m	Limit dBuV/m	Over dB	Detector
1	*	1632.040	30.74	-2.12	28.62	50.00	-21.38	AVG
2		1640.000	43.29	-2.14	41.15	70.00	-28.85	peak

Remark:

1. Corr. = Antenna Factor (dB/m) + Cable Loss (dB)
2. Peak/AVG (dBμV/m)= Corr. (dB/m)+ Read Level (dBμV)
3. Margin (dB) = Peak/AVG (dBμV/m)-Limit PK/AVG(dBμV/m)

Attachment C--Voltage Fluctuation and Flicker Test Data

Test Result: Pass

Status: Test Completed

Pst and limit line

European Limits

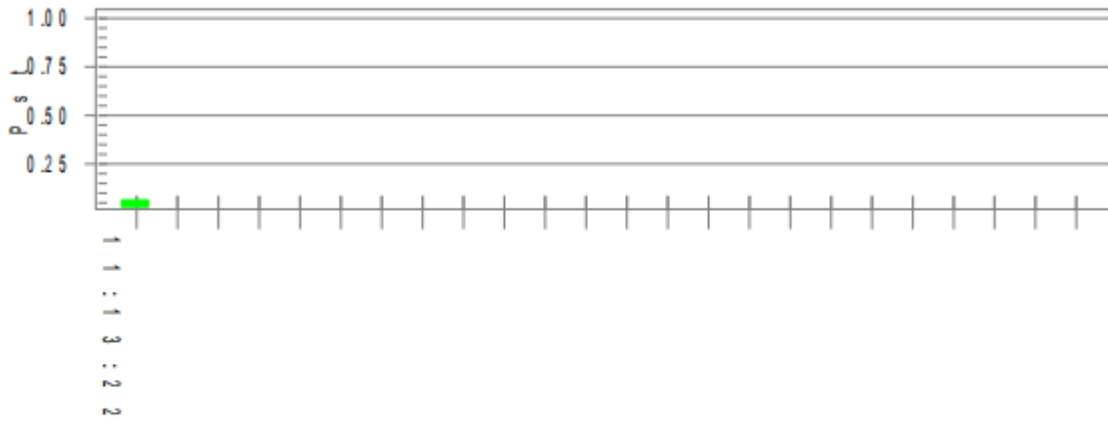

Plt and limit line

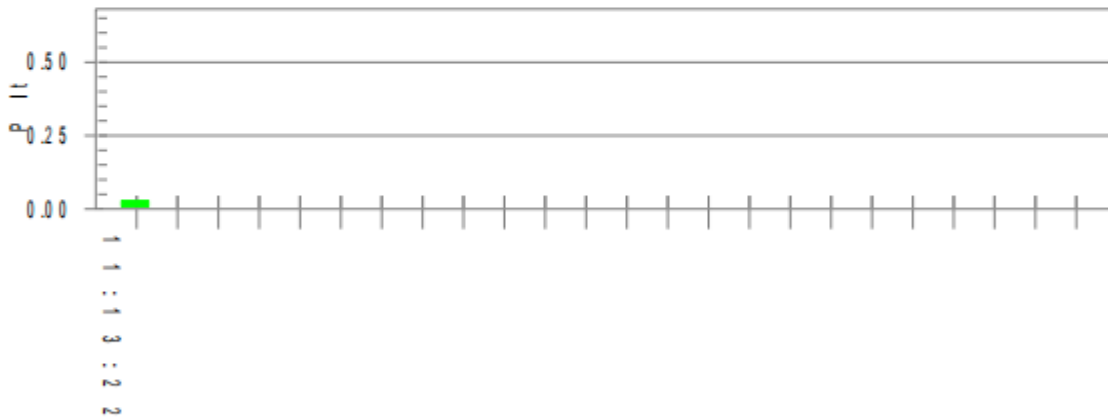

Parameter values recorded during the test:

Vrms at the end of test (Volt):	227.30		
T-max (mS):	0	Test limit (mS):	500.0 Pass
Highest dc (%):	0.00	Test limit (%):	3.30 Pass
Highest dmax (%):	0.00	Test limit (%):	4.00 Pass
Highest Pst (10 min. period):	0.064	Test limit:	1.000 Pass
Highest Plt (2 hr. period):	0.028	Test limit:	0.650 Pass

Attachment D--Electrostatic Discharge Test Data

Temperature : 22.4°C		Humidity : 43%	
Power supply : AC 230V/50Hz		Test Mode : Mode 7	
Required Performance Criteria: B			
Air Discharge: ±2/±4/±8kV Contact Discharge: ±2/±4kV			
Location	Test Level (kV)	Judgment	Result
A1	±2kV ±4kV ±8kV	A	PASS
C1,C2,C4,C6, C7	±2kV ±4kV	A	
C3,C5	±2kV ±4kV	B	
HCP	±4kV	A	
VCP	±4kV	A	
Note: "/" Representative the test not applicable			

Test Location Photos

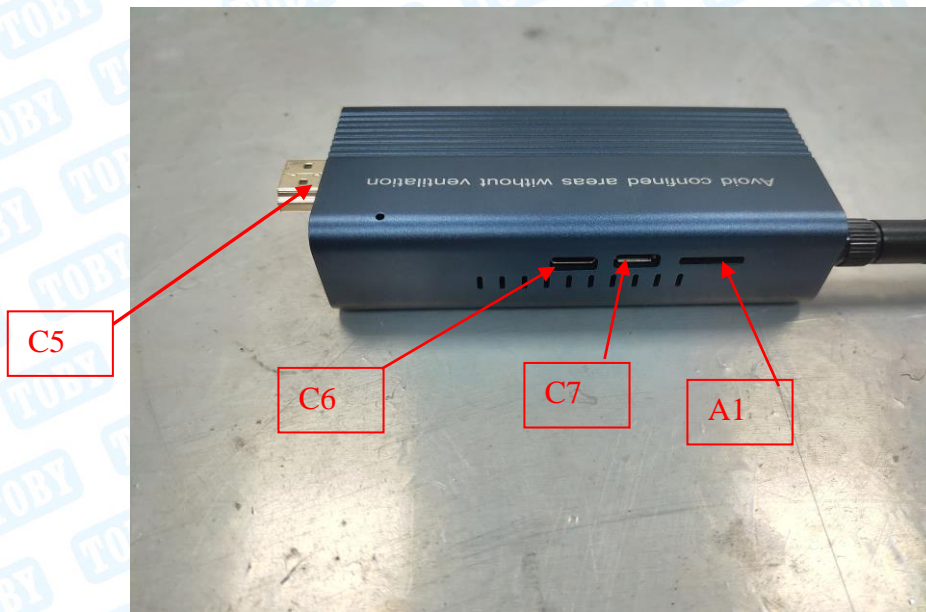
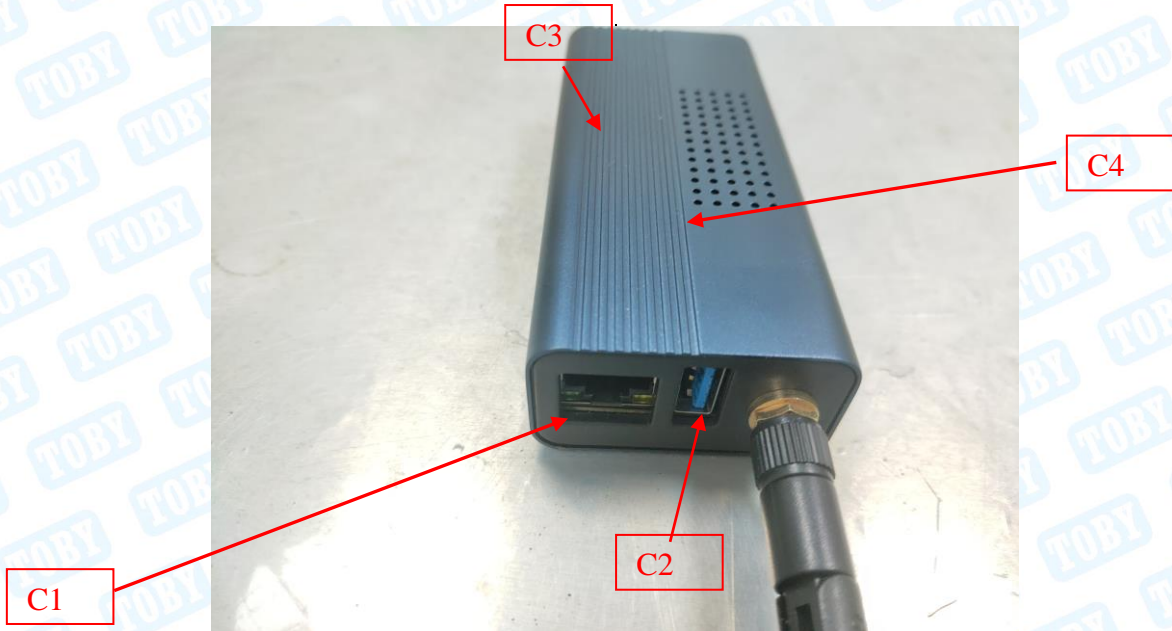

Attachment E--RF Field Strength Susceptibility Test Data

Temperature : 22.4°C		Humidity : 43%			
Power supply : AC 230V/50Hz		Test Mode : Mode 7			
Required Performance Criteria: A					
Modulation: AM 80%					
Pulse: 1 kHz					
EUT Position	Actual Performance Criteria				Judgment
	Frequency Range 1: 80~1000MHz		Frequency Range 2: 1000~6000MHz		
	Horizontal	Vertical	Horizontal	Vertical	
Front	A	A	A	A	PASS
Right	A	A	A	A	PASS
Rear	A	A	A	A	PASS
Left	A	A	A	A	PASS

Attachment F--Electrical Fast Transient/Burst Test Data

Temperature : 22.4°C		Humidity : 43%					
Power supply : AC 230V/50Hz		Test Mode : Mode 7					
Required Performance Criteria: B							
Line : <input checked="" type="checkbox"/> AC Mains Coupling : <input checked="" type="checkbox"/> Direct							
Line : <input type="checkbox"/> Signal <input type="checkbox"/> I/O Cable Coupling : <input type="checkbox"/> Capacitive							
Line	Voltage(kV)	Required Performance Criteria		Actual Performance Criteria		Judgment	
		(+)	(-)	(+)	(-)		
AC LINE	L	1.0	B	B	A	A	PASS
	N	1.0	B	B	A	A	PASS
	L-N	1.0	B	B	A	A	PASS
	L-PE	1.0	/	/	/	/	/
	N-PE	1.0	/	/	/	/	/
	L-N-PE	1.0	/	/	/	/	/
DC Line	/	/	/	/	/	/	/
Wired Network Port	/	/	/	/	/	/	/

Attachment G--Surge Immunity Test Data

Temperature	: 22.4°C	Humidity	: 43%			
Power supply	: AC 230V/50Hz	Test Mode	: Mode 7			
Required Performance Criteria: B						
(Tr/Th: 1.2/50us for AC Power Port; Tr/Th: 10/700us for signal lines)						
Injected Line	Voltage (kV)	Phase	Actual Performance Criteria		Result	
			(+)	(-)	(+)	(-)
L-N	1.0	0°	A	A	PASS	PASS
		90°	A	A	PASS	PASS
		180°	A	A	PASS	PASS
		270°	A	A	PASS	PASS
L-PE, N-PE	2.0	0°	/	/	/	/
		90°	/	/	/	/
		180°	/	/	/	/
		270°	/	/	/	/
L-N-PE	2.0	0°	/	/	/	/
		90°	/	/	/	/
		180°	/	/	/	/
		270°	/	/	/	/
Wired Network Port	1.0	+/-	/	/	/	/

Attachment H--Conducted Immunity Test Data

Temperature	: 22.4°C	Humidity	: 43%
Power supply	: AC 230V/50Hz	Test Mode	: Mode 7
Required Performance Criteria: A			

Frequency Range (MHz)	Injected Position	Voltage Level (e.m.f.)	Required Performance Criteria	Actual Performance Criteria	Result
0.15 ~ 80	AC Mains	3V(rms), AM 80% Modulated with 1 kHz	A	A	PASS
0.15 ~ 80	DC Mains	3V(rms), AM 80% Modulated with 1 kHz	A	/	/
0.15 ~ 80	Wired Network Port	3V(rms), AM 80% Modulated with 1 kHz	A	/	/

Attachment I--Voltage Dips and Interruptions Test Data

Temperature :	22.4°C	Humidity :	43%
Power Supply :	AC 230V/50Hz	Test Mode :	Mode 7
Required Performance Criteria: B&C			
Test Results Description			
Voltage Reduction	Cycles	Required Performance Criteria	Judgment
Voltage dip 100%	0.5	B	PASS
Voltage dip 100%	1	B	PASS
Voltage dip 30%	25	C	PASS
Voltage Interruption100%	250	C	PASS

-----END OF REPORT-----